

Infilex™ ZM

Zone Manager

Model WY5122

General

Infilex ZM (Infilex: named for “Infinity” and “Flexible”) Model WY5122, integrated into savic-net FX™ BMS (building management system), manages remote units (also called sub-controllers), such as Infilex VC, Infilex FC, and Infilex SC.

Up to 50 remote units can be connected. Infilex ZM can control these units separately as well as per group.

Infilex ZM communicates with the savic-net™ FX center unit through the transmission trunk line NC-bus and with the remote units through the transmission trunk line SC-bus.



Features

- Compact design:
Small size body ensures space saving.
- Installation:
A quick-fit screwless (clamp) terminal block is used for the communication terminal block of the I/O module, ensuring the labor saving of the wiring work.
Additionally, either DIN rail mounting or screw mounting can be selected.
- Management of remote units:
Infilex ZM manages up to 50 connected remote units (Infilex VC, Infilex FC, Infilex SC, etc.), allowing ON/OFF, failure monitoring, measuring, and setting individually from the BMS center unit. Infilex ZM can perform such managements of remote units by group and is applicable to any group configuration consisting of up to 50 units of Infilex VC and Infilex FC. Additionally, Infilex ZM provides flexible management. For example, group ON/OFF can be commanded even when individual measuring is commanded.
- Risk diversification and high-speed supervision:
Infilex ZM has 50 programs of time schedules, analog alarm monitoring, and runtime/cycle-count integrating in order to manage the connected Infilex VC, Infilex FC, Infilex SC, etc. This achieves diversification of risks and high-speed supervision of BMS.
- One Infilex ZM controls up to 4 sets of VAV (VAV: variable air volume, controlled by Infilex VC) and AHU (controlled by Infilex GC). Load reset control of supply air temperature, fan speed control, interlocking operation are available. Additionally, the mixing loss control of the interior VAV and perimeter FCU (fan coil unit) can be performed.
- Support functions:
Infilex ZM supports to adjust VAV by setting the max./min. air volume levels of all VAV units included in a specified set. Infilex ZM also supports to adjust AHU/FCU flow rate and to flush the piping by fully opening and closing all the valves that the Infilex ZM controls.
- CE Marking certified product:
Infilex ZM Model WY5122W0000 (NC-bus model (Line A)) conforms to all the applicable standards of CE Marking (Class A).



* Yamatake's controller Infilex series: Infilex is named for “Infinity” and “Flexible”.







Safety Instructions

Please read instructions carefully and use the product as specified in this manual. Be sure to keep this manual near by for ready reference.















Usage Restrictions

This product is targeted for general air conditioning. Do not use this product in a situation where human life may be affected. If this product is used in a clean room or a place where reliability or control accuracy is particularly required, please contact Yamatake's sales representative. Yamatake Corporation will not bear any responsibility for the results produced by the operators.

WARNING

-  • DANGER: To prevent the risk of severe or fatal electrical shock, always disconnect power source and product power supply before performing any wiring.
-  • Be sure to ground with 100 Ω or lower ground resistance. Improper grounding may cause electrical shock or equipment damages.
-  • Do not detach the terminal cover at any time except when wiring. After wiring, be sure to attach the terminal cover. Before attaching/detaching the terminal cover, make sure that the wires are not current-carrying to prevent electrical shock.
-  • Disconnect power before the product replacement to prevent electrical shock.
-  • Wire strip length to be connected to the quick-fit screwless terminal block must be 8 mm. If the strip length is longer than 8 mm, the conductor will be exposed, causing electrical shock or short circuit between adjacent terminals. If it is shorter, the conductor will not contact the connector.
-  • Do not disassemble the product. Disassembly may result in electrical shock or equipment damage.

CAUTION

-  • Installation and wiring must be performed by qualified personnel in accordance with all applicable safety standards.
-  • This product must be operated under the operating conditions (power, temperature, humidity, vibration, shock, installation position, atmospheric condition, etc) specified in this manual to prevent equipment damages.
-  • All wiring must comply with local codes of indoor wiring and electric installation rules.
-  • Use crimp terminal lugs with insulation for electric wires connected to the screw terminals.
-  • Connect cables to the power source with terminals or the like for permanent connection.
-  • Make sure all the wires are tightly connected to prevent heat generation or equipment damages.
-  • If more than the rated power supply voltage is applied, product replacement is required for safety.
-  • Install this product in a location out of reach of unauthorized people. (e.g. Inside of the control panel cabinet)
-  • Lightning protection based on the regional characteristics and the building structure is needed to minimize equipment damages.
-  • Noise protection is necessary when the product is installed in a location close to many noise sources.
-  • Do not block the vent holes on the upper or lower part of the product to prevent equipment damages. Remove protective sheet after installation and wiring.
-  • After mounting on DIN rail, make sure that the holding parts of all the connected modules are securely fixed on the DIN rail. The modules may drop from the DIN rail and get damaged due to improper mounting.
-  • Dispose of the lithium battery in accordance with your local regulations.
-  • Dispose of this product in accordance with your local regulations. Do not reuse all or a part of this product.

Trademark information:

Infilex, Neopanel, PARAMATRIX and savic-net are trademarks or registered trademarks of Yamatake Corporation in Japan or in other countries.

BACnet is a registered trademark of American Society of Heating, Refrigerating and Air-Conditioning Engineers (ASHRAE).

System Configurations

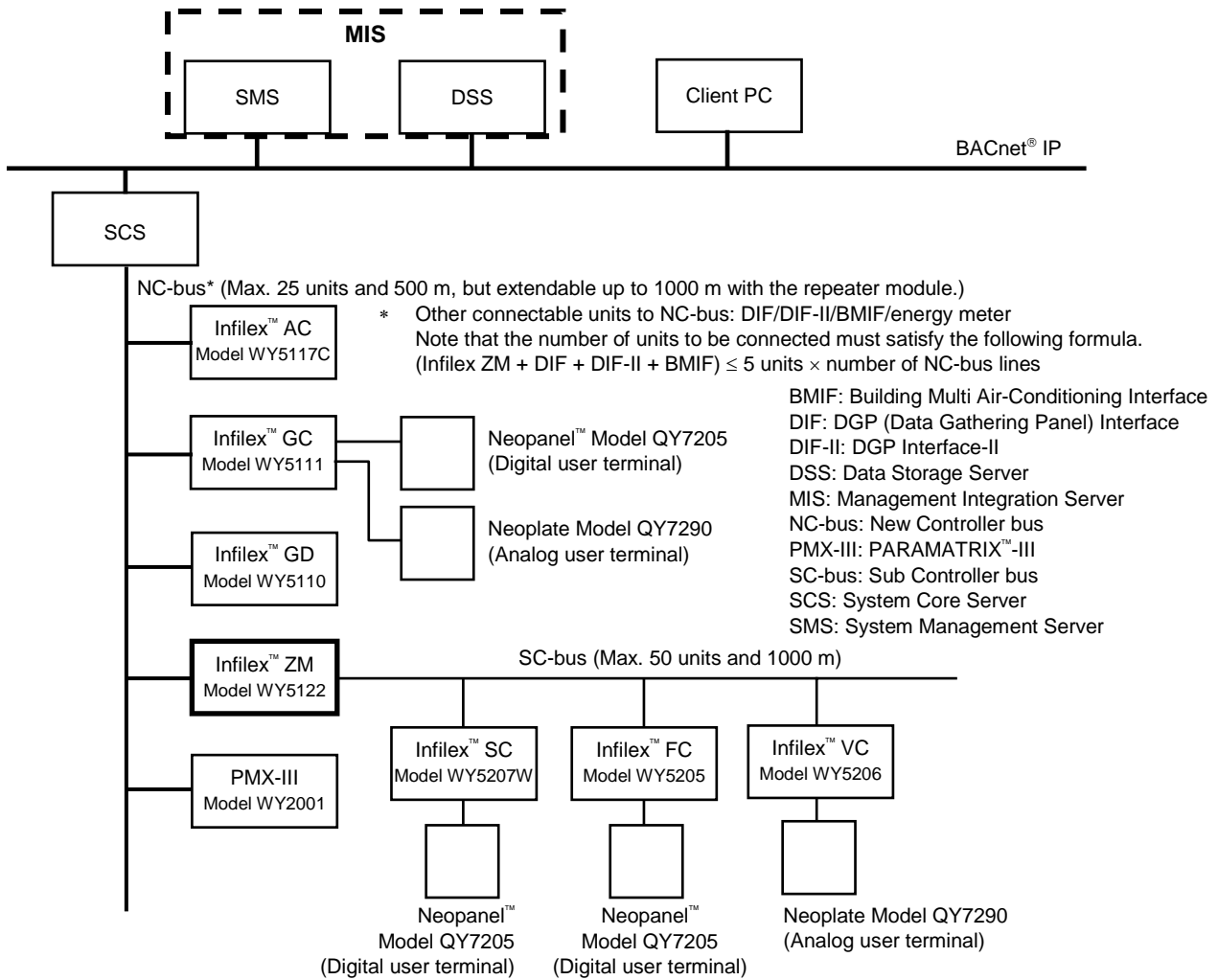

Note:
 MIS may be used instead of SMS and DSS for your system. Note that MIS cannot be mixed with SMS or DSS in the same system.

Figure 1. System configuration example

Model Numbers

Model number	Description
WY5122	Basic model number
W	100 V AC to 240 V AC power
0000	NC-bus model (Line A) * CE Marking (Class A) certified
0010	Redundant NC-bus model (Lines A and B)

Parts for Installation

Part number	Description
83165861-001	Screw tab
83104567-001	DIN rail mounting bracket

Note:
 For mounting Infilex ZM, either the screw tab (for screw mounting) or the DIN rail mounting bracket (for DIN rail mounting) is required. Be sure to separately order depending on your mounting type.

Specifications

Basic specifications

Item		Specification				
Power supply	Rated voltage	100 V AC to 240 V AC, 50 Hz/60 Hz				
	Allowable voltage range	85 V AC to 264 V AC, 50 Hz/60 Hz				
	Power shutdown detection	80 V AC or less				
	Power consumption	35 VA (when 50 remote units (sub- controllers) are connected from the Infilex ZM)				
Environmental conditions	Rated operating conditions	Ambient temperature	0 °C to 50 °C			
		Ambient humidity	10 %RH to 90 %RH (non-condensing)			
		Altitude	2000 m or lower			
		Vibration	Max. 5.9 m/s ² (0.6 G) at 10 Hz to 150 Hz			
	Transport/ storage conditions	Ambient temperature	-20 °C to 60 °C			
		Ambient humidity	5 %RH to 95 %RH (non-condensing)			
		Vibration for storage	Max. 5.9 m/s ² (0.6 G) at 10 Hz to 150 Hz			
		Vibration for transportation	Max. 9.8 m/s ² (1 G) at 10 Hz to 150 Hz			
LED indication	Operation	Power supply (POWER)	Green LED ON:	Power ON		
			Green LED OFF:	Power OFF		
		Major failure (ERR1)	Red LED ON:	Major failure or system restart		
			Red LED OFF:	Normal operation		
		Minor failure (ERR2)	Red LED ON:	Minor failure or system restart		
			Red LED OFF:	Normal operation		
	Communication	NC-bus	Transmit (TX), Receive (RX)			
		SC-bus	Transmit (TX), Receive (RX)			
	Description of LED indication	LED	Flashing	ON	OFF	
		POWER	—	ON	OFF	
		NC-bus TX	Normal	Abnormal	—	
		NC-bus RX	Normal	Abnormal	—	
		SC-bus TX	Normal	Abnormal	—	
		SC-bus RX	Normal	Abnormal	—	
ERR1		—	Abnormal	Normal		
ERR2		—	Abnormal	Normal		
Power failure backup		RAM, RTC*	Lithium battery backup			
		Data file	Non-volatile memory (flash memory) backup			
Communications	NC-bus	Transmission system	Current transmission			
		Transmission speed	4800 bps			
		Transmission distance	500 m			
		Remote units (controllers)	Max. 25 units connectable			
	SC-bus	Transmission system	Voltage transmission			
		Transmission speed	4800 bps			
		Transmission distance	1000 m			
		Remote units (sub-controllers)	Max. 50 units connectable			
Weight		400 g				
Material (housing), color		Modified PPE, light gray				
Terminal block	Power supply, ground	M3 (7.62 mm pitch between terminals)				
	NC-bus communication	Quick-fit screwless terminal block				

Note:

* RTC: Real Time Clock. RTC is backed up by a lithium battery to ensure accurate clocking while the power is OFF.

Wiring specifications

Item	Wiring	Wiring length	Condition
Power supply	JIS IV2.0 mm ² or JIS CVV 2.0 mm ² or greater	—	—
Ground	JIS IV 2.0 mm ² or JIS CVV 2.0 mm ² or greater	—	Ground resistance: 100 Ω or lower
NC-bus	JCS IPEV-S 0.9 mm ²	500 m	—
SC-bus	LAN cable compliant with EIA/TIA-568 category 3 or over	1000 m	—

Notes:

- * As M3 screw terminal block is used for power supply and ground, crimped terminal lug is required for the cable end.
- * Since a quick-fit screwless terminal block is provided for NC-bus connection, the wires can be connected only by stripping the sheath. Sheath stripped length: 8 mm (Pin terminal cannot be used.)
- * Organize the cables with cable binding bands so as not to hide LED, Data Setter connector, ► mark, switch, battery holder, or tag.
- * JIS: Japanese Industrial Standards
- * JCS: Japanese Electric Wire and Cable Makers' Association

Input/Output Terminal Arrangement

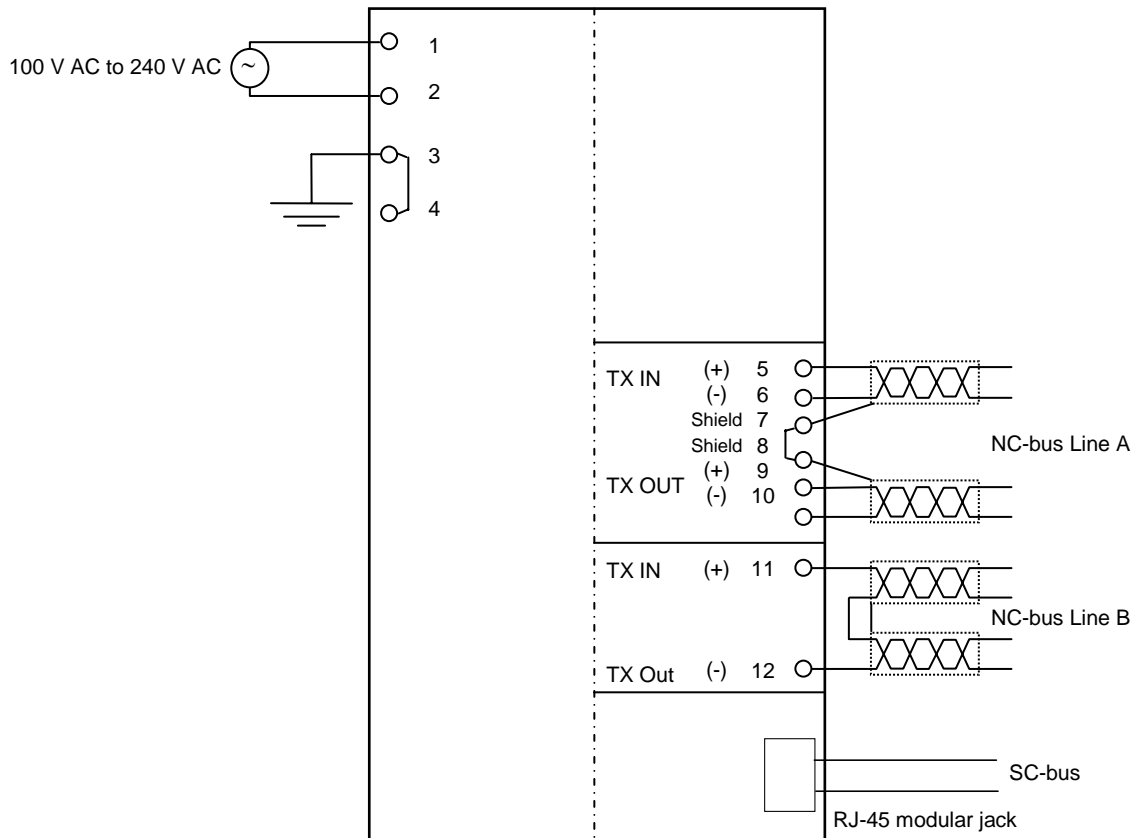

Figure 2. Input/output and terminal arrangement example

Dimensions

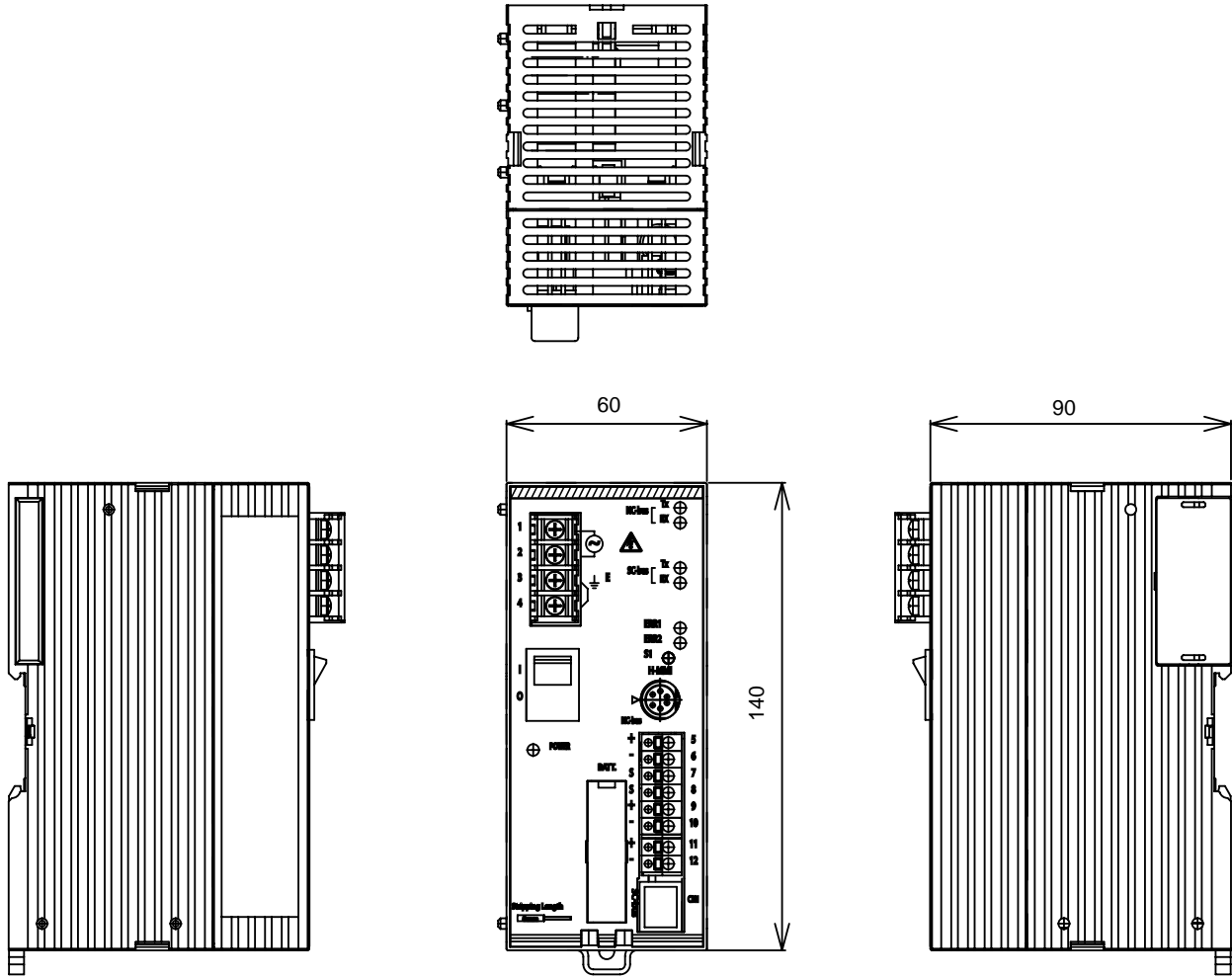

Figure 3. Dimensions (mm)

Parts Identification

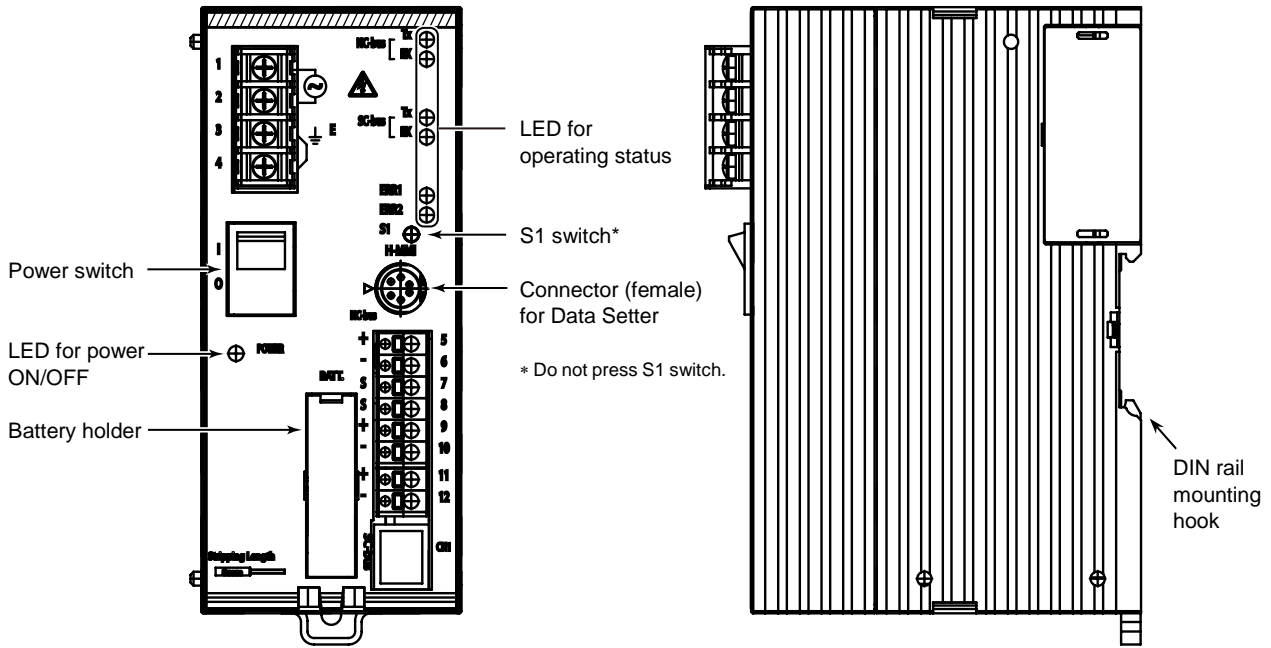

Figure 4. Parts identification

Table 1. Indication and operation of operating status LED

LED indication	LED operation
Data transmitting	NC-bus TX LED: flashing
Data receiving	NC-bus RX LED: flashing
Data transmitting	SC-bus TX LED: flashing
Data receiving	SC-bus RX LED: flashing
Major failure / initializing	ERR1: ON
Minor failure / initializing	ERR2: ON

Connections of Data Setter (H-MMI)

- 1) Connection of Data Setter Model QY5111A
 No conversion cable is required. Directly insert the male connector of the Data Setter into the female connector provided on the Inflex ZM main unit.
 At this time, hold the male connector with the ◀ mark facing left and insert it as the mark points to the ▶ mark on the Inflex ZM main unit.
- 2) Connection of Data Setter Model QY7211A
 Convert the D-SUB connector to the mini DIN connector with the conversion cable (Part No. 83104995-001).
 At this time, hold the male connector with the ◀ mark facing left and insert it as the mark points to the ▶ mark on the Inflex ZM main unit.

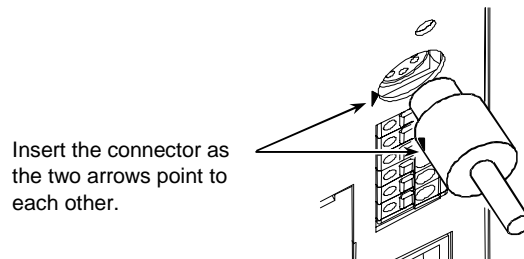

Figure 5. Connecting Data Setter

Mounting Dimensions

DIN rail mounting

Mount and fix Infilex ZM on DIN rail so that it does not fall from the DIN rail.

Fasten the bilateral sides of Infilex ZM with two DIN rail mounting brackets (Part No. 83104567-001, separate order is required).

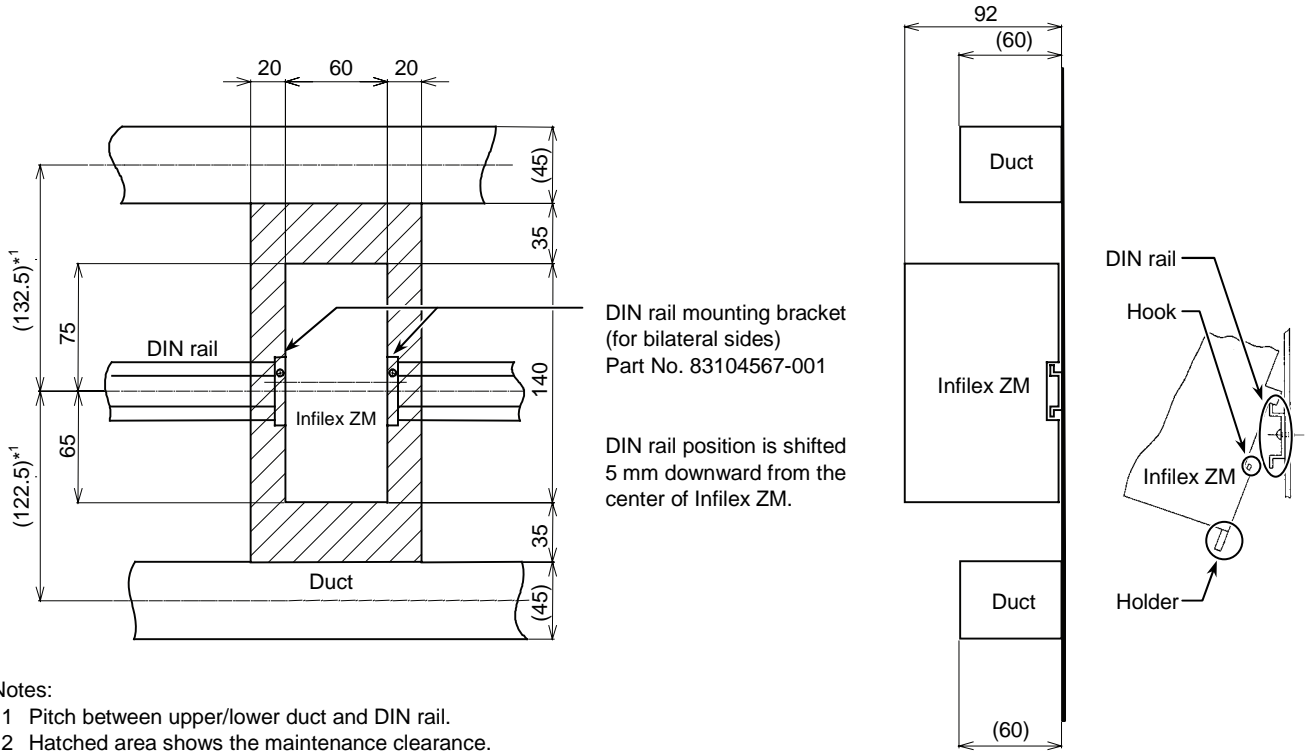

Figure 6. Mounting dimensions: DIN rail mounting (mm)

Direct screw-mounting

When Infilex ZM is mounted with screws, the screw tab (Part No. 83165861-001) is required.

Mount and fix Infilex ZM on the wall with two M4 × 8 screws.

Lengthwise mounting

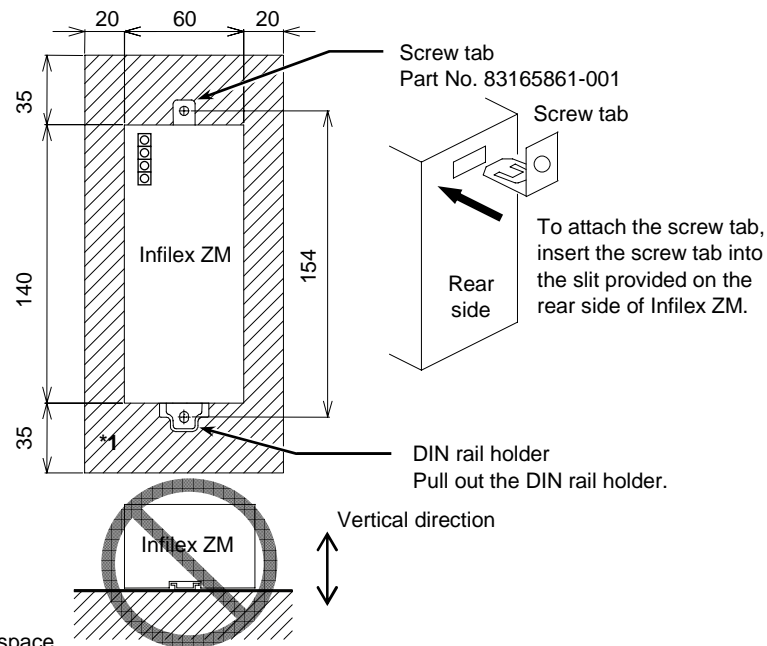

Figure 7. Mounting dimensions: Direct screw mounting (mm)

Wiring

Wiring from power supply to terminal block

Attach the crimp terminals for the M3 screw terminal block to the wire ends, and connect them to the terminal block.

Wiring to the NC-bus Terminal Block

Since quick-fit screwless terminal block is used for the NC-bus terminal block, the procedure for wiring is specified as follows.

- 1) Strip the wire sheath 8 mm. (The gauge for the strip length is located at the front lower part of Inflex ZM main unit. If the stripped part is longer than 8 mm, the conductor will be exposed, causing electrical shock or short circuit between adjacent terminals. If it is shorter, the conductor may not contact the connector.)
- 2) Make sure that no wire fiber is protruded from the stripped conductor.
- 3) Press the button on the terminal block deeply enough to insert the wire using a slotted screwdriver. (Maximum button-pressing force is 14 N {1.4 kgf}.)
- 4) Release the button, and gently pull out the wire to make sure that it is tightly fastened. (If you pull out the wire diagonally, it may be disconnected.) Make sure that no wire fiber is protruded from the stripped conductor.

Precautions for connected cables

Neatly place the cables connected to Inflex ZM so as not to hide the parts shown in Fig. 8. Make sure there is no slack in the wires from the cable ducts to Inflex ZM.

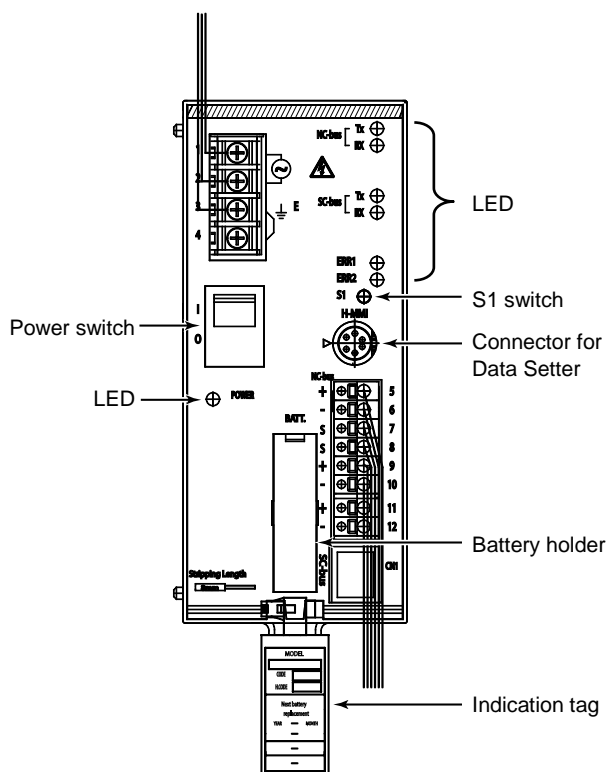

Figure 8. Connected wires in position

System indication label for the controller number

The indication tag has the system indication label on its back.

Turn it over and fill in the controller number on the label.

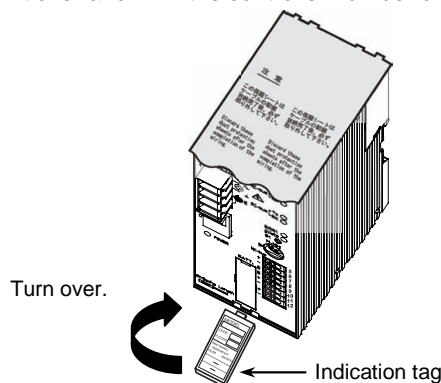

Figure 9. System indication label

Protective sheet

After wiring installation, be sure to peel off the protective sheet before turning on the power.

- 1) Adhesive is applied to the sheet approximately 20 mm from the front edge. Peel off this area.
- 2) Tear off the sheet along the perforations.
 - 2) Tear off.

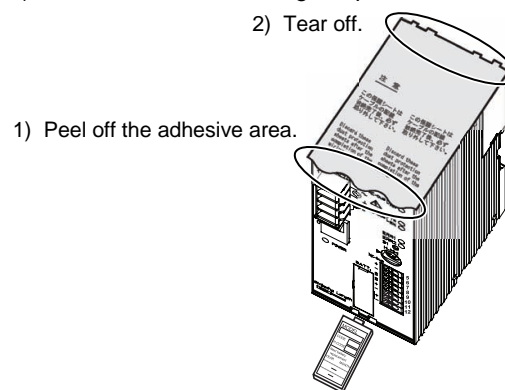

Figure 10. Protective sheet

Tube marker

Since Inflex ZM adopts quick-fit screwless terminal block for communication, communication cables are connected to the terminals without crimp terminal lugs. Therefore, if normal tube markers are used, they may come off when the cables are disconnected. To prevent this, use the Flat Tube Marker. It is held on a cable by friction and thus does not come off easily.

Manufacturer	Phoenix Contact
Part name	Flat Tube Marker
Part number	5880029
Model	TMC-3
Applicable wire size	0.4 mm ² to 2 mm ²
Package unit	200 m/roll

Maintenance (Lithium Battery Replacement)

Replace the lithium battery for backup (Part No. 83104934-001) every 5 years.

IMPORTANT:

- Only authorized service personnel is allowed to replace the battery.
- Do not touch the power supply unit when replacing the battery.
- Since the remaining battery capacity cannot be checked by measuring the terminal voltage, be sure to replace the battery every 5 years.
- Replace the lithium battery with the power ON.
- Replace the lithium battery every 5 years if the product is always in use (in ON state).
- If the product has never or hardly been operated (in OFF state) for a year, replace the lithium battery before the product operation.

Battery replacement

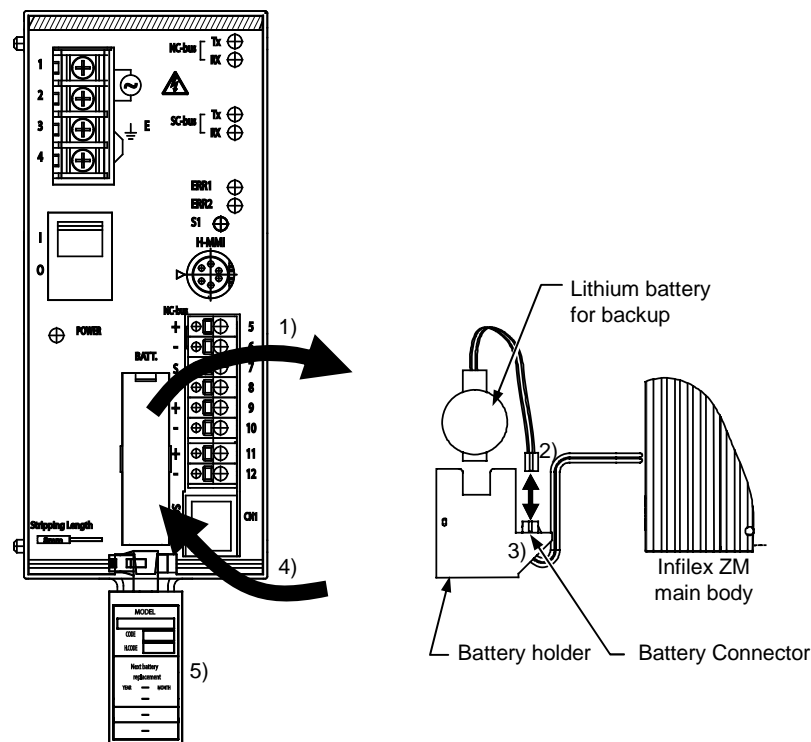

* Replace the battery with the Infilex ZM in ON state.

Figure 11. Battery replacement

- 1) Pull out the battery holder using a slotted screwdriver.
- 2) Disconnect the connector and detach the lithium battery from the battery holder.
- 3) Place a new lithium battery in the battery holder and connect the connector to it.
- 4) Insert the battery holder into the main unit.
- 5) Fill in the date for next replacement (5 years after the replacement) on the tag using an oil-based pen.

Precautions for Use

- Do not mount the product under the conditions of high temperature and humidity.
- Do not drop the product.
- For the wire replacement, be sure to shut down the power. (Disconnect the wiring between the power supply and the product power terminals.)
- Before turning on the power, make sure that the wires are correctly connected.
- Several tens of seconds are required for the product normal operation after the power is turned on. During this time, the red LED "ERR1" (major failure) on the front lights up indicating major failure temporarily, but this does not indicate an error.
- Do not connect wires to vacant terminals.
- Leave at least 35 mm clearance between the top/bottom surfaces of the product and other devices.
- Peel off the protective sheet on the top surface of the product before turning ON the power. (See Figs. 10 and 12.)

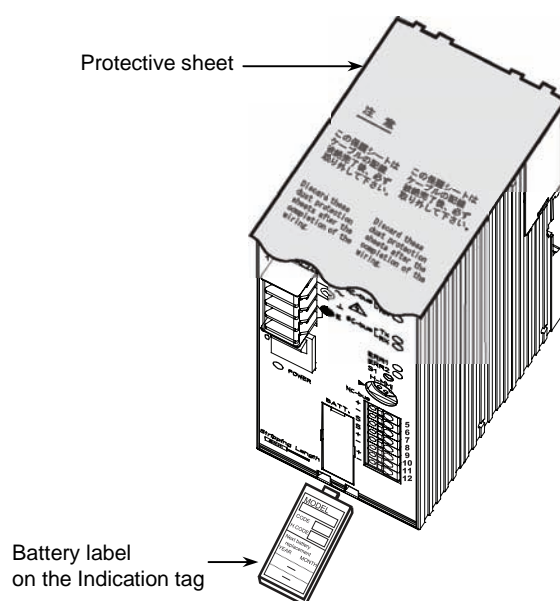

Figure 12. Battery label on the indication tag and protective sheet

azbil

Specifications are subject to change without notice.

Yamatake Corporation
Building Systems Company

<http://www.yamatake.com>