

Large size Color Programmable Display Smart Terminal EST555Z

The EST555Z Smart Terminal is a next-generation large size programmable display adopting the multi-channel communication and memory card. This Smart Terminal uses a high-precision TFT device.

It has the capability of producing vividly 256-color display with drawings of bit-mapped images, etc., and the application creation can be simply worked out with a new AP editor coping with Windows 98/Me/XP.

Smart objects (pictures + operating settings) can be selected from the library like the feeling of pasting them. Several interfaces to external devices are provided, such as serial communication port, infrared ray transmission port (IrDA), and memory card (compact flash memory card).

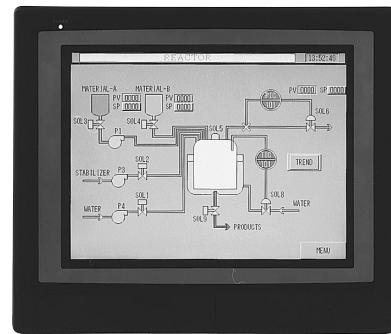

■ Features

- Multi-channel structure with RS-232C (one channel), RS-485 (3-channel) and infrared ray transmission port provided on the front side. It can also cope with the same applications to support simultaneously programmable logic controllers (PLCs) and controllers.
- Instrumentation objects are available that allow long-term storage of up to 64-channel data. (The data can be stored for approximately 3 months assuming that the interval is 30 sec.)
- The DMC10 package is available to realize the loader and the monitoring functions of module type controllers without programming.
- Realized 256-color display with vivid image drawings. It can clearly draw the images taken by a digital camera.
- The software of the AP editor for picture creation is considerably enhanced in its maneuverability to cope with Windows 98/Me/XP. Furthermore, it can gently support the creation of application data by utilizing smart objects.
- Easy to replace the components such as the display unit from front side, thus, providing the easiness in maintenance.
- The protective structure of IP64 is assured despite of the provision for the infrared ray transmission port. The installation location is not restricted.
- The memory card (compact flash memory card) is provided on the front. Use of this memory card makes it possible to save or transmit applications and to save the trend data using the instrumentation objects.

■ System Configuration

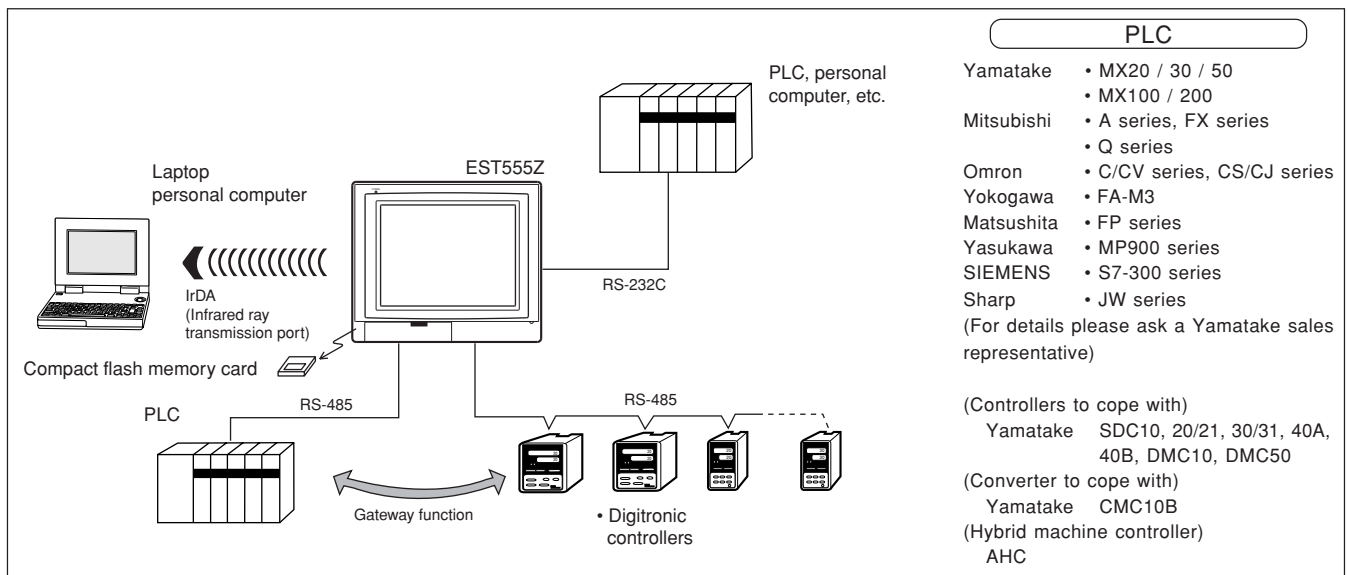

■ Name of Each Component

● The front

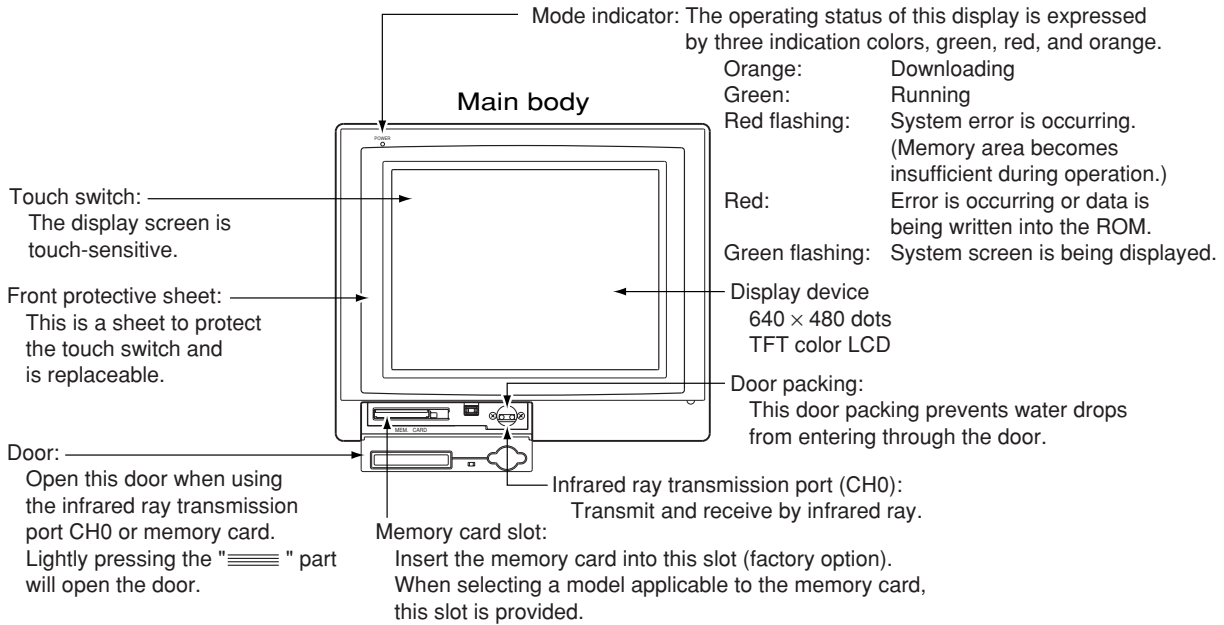

● The rear

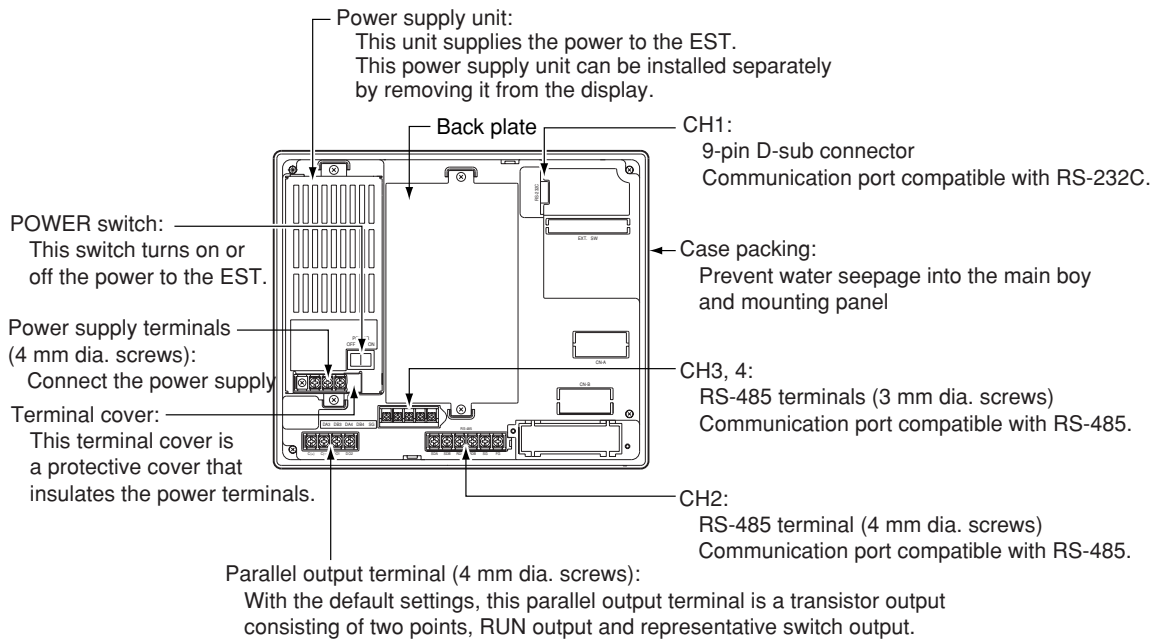



■ Part material and environment resistance

Part	Material	
Case display unit chassis	PC/ABS	Rather being resistant to water, alcohol, oil, salt and weak acid but has effects of swelling and dissolution by alkaline, aromatic hydrocarbon and halogen acid.
Touch switch front protective sheet	PET (polyethylene terephthalate)	PET is susceptible to damage by strong acid, alkaline, boiling water and water and water vapor but has extremely high resistance to organic solvent and oily substances.
Door packing	EPDM (Ethylene propylene rubber)	The surface material is a continuous foaming type flexible foam material that the mixture, in which the flame retardant is mixed with EPDM, is foamed General mineral oil may adversely affect this rubber. The ozone resistance is excellent, and the heat resistance and heat aging resistance are good, ensuring the good resistance to the over-heated steam.
Case packing	CR (Chloroprene rubber)	The raw material is a flexible foam material having the independent foaming structure that CR is foamed. The ozone resistance is excellent next to EPDM, and the heat resistance and oil resistance are good. This material also has the autolysis ability.
Back plate	Incombustible/heat-resistant vinyl chloride sheet	Material has rigidity insulation resistance, excellent weatherability, water resistance and chemical resistance. It has low resistance to hydro-carbon, ester, ketone, aldehyde, uric acid, chlorinated solvent and rosin.

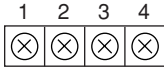
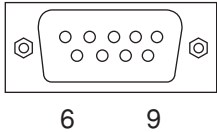
■ Specifications

Display unit	Display element	TFT color LCD																																																									
	Display color	256 colors (bitmap display) / 64 colors (object display)																																																									
	Resolution	640 × 480 dots																																																									
	Dot pitch	0.33 mm																																																									
	Display unit life (at room temperature)	50,000 hrs.																																																									
	Back-light life (at room temperature)	Approx. 30,000 hrs. at room temperature in a half brightness (before date code 0208), Approx. 50,000 hrs. (after date code 0212)																																																									
	Back light	Turning-off is possible by time setting																																																									
	Display attribute	Blinking and color change																																																									
	Display character type	ANK: 158, kanji character: 6349 (including 453 symbols, JIS level 1 and 2 kanji sets)																																																									
	Display character number	80-character × 60-line (8 × 8 dots)																																																									
		80-character × 30-line (8 × 16 dots)																																																									
		40-character × 30-line (16 × 16 dots)																																																									
	Display character size	1 to 8 integers in vertical and horizontal directions																																																									
	Graphic element	Straight line, rectangle, circle, circular arc, ellipse, optional patterns, etc.																																																									
	Graphic display	Bar graph and line graph																																																									
Display unit function	Numeric, lamp display, character string, sub-screen display, etc.																																																										
Screen memory	Memory capacity	2 M bytes																																																									
	No. of registered screens	999 panels (maximum number changes depending applications)																																																									
	Panel display	Simultaneously up to 8 panels																																																									
Touch switch	Switching method	Transparent resistance membrane																																																									
	Life	1 million times (by finger inputting)																																																									
DC input/output interface	Point number	Output: 2																																																									
	Output form	NPN transistor																																																									
	Dielectric strength	30 Vdc																																																									
	Leak current	0.3 mA max.																																																									
	Load voltage range	4.5 to 27.6 Vdc, 10mA																																																									
	Connector	4 mm dia. terminal block																																																									
	 <table border="1" data-bbox="783 1122 1331 1279"> <thead> <tr> <th>Pin No.</th> <th>Signal name</th> <th>Contents</th> </tr> </thead> <tbody> <tr> <td>1</td> <td>C (+)</td> <td>Power supply input for output signal</td> </tr> <tr> <td>2</td> <td>C (-)</td> <td>Output signal ground</td> </tr> <tr> <td>3</td> <td>DO1</td> <td>Output signal 1</td> </tr> <tr> <td>4</td> <td>DO2</td> <td>Output signal 2</td> </tr> </tbody> </table>				Pin No.	Signal name	Contents	1	C (+)	Power supply input for output signal	2	C (-)	Output signal ground	3	DO1	Output signal 1	4	DO2	Output signal 2																																								
Pin No.	Signal name	Contents																																																									
1	C (+)	Power supply input for output signal																																																									
2	C (-)	Output signal ground																																																									
3	DO1	Output signal 1																																																									
4	DO2	Output signal 2																																																									
Communications (CH0) Interface	Communications standard	Infrared ray communications (IrDA 1.0 equipment)																																																									
	Transmission distance	0.4 to 1 m																																																									
	Unit connection number	1 unit																																																									
	Transmission speed	9600, 19200, 38400, 57600 and 115200 bps																																																									
Communications (CH1) Interface	Communication standard	RS-232C equipment																																																									
	Transmission distance	15 m																																																									
	Unit connection number	1 unit																																																									
	Transmission speed	9600, 19200, 38400, 57600, and 11520 bps																																																									
	Connector	Applicable connector: Daiich Denshi Kogyo Co. 17JE-13090-02 (D8C2) or equivalent D - sub 9 pin																																																									
	 <table border="1" data-bbox="783 1738 1485 2092"> <thead> <tr> <th>Pin No.</th> <th>Signal name</th> <th>Contents</th> <th>Channel</th> <th>Input/Output</th> </tr> </thead> <tbody> <tr> <td>1</td> <td>NC</td> <td>No connection</td> <td></td> <td></td> </tr> <tr> <td>2</td> <td>RD1</td> <td>Receive data</td> <td>CH1</td> <td>Input</td> </tr> <tr> <td>3</td> <td>SD1</td> <td>Send data</td> <td>CH1</td> <td>Output</td> </tr> <tr> <td>4</td> <td>ER1</td> <td>DR (6-pin) and internal connection</td> <td>CH1</td> <td></td> </tr> <tr> <td>5</td> <td>SG</td> <td>Signal ground</td> <td></td> <td></td> </tr> <tr> <td>6</td> <td>DR1</td> <td>ER (4-pin) and internal connection</td> <td>CH1</td> <td></td> </tr> <tr> <td>7</td> <td>RS1</td> <td>Request to send</td> <td>CH1</td> <td>Output</td> </tr> <tr> <td>8</td> <td>CS1</td> <td>Transmission enable</td> <td>CH1</td> <td>Input</td> </tr> <tr> <td>9</td> <td>NC</td> <td>No connection</td> <td></td> <td></td> </tr> <tr> <td>Shell</td> <td>-</td> <td>No connection</td> <td></td> <td></td> </tr> </tbody> </table>				Pin No.	Signal name	Contents	Channel	Input/Output	1	NC	No connection			2	RD1	Receive data	CH1	Input	3	SD1	Send data	CH1	Output	4	ER1	DR (6-pin) and internal connection	CH1		5	SG	Signal ground			6	DR1	ER (4-pin) and internal connection	CH1		7	RS1	Request to send	CH1	Output	8	CS1	Transmission enable	CH1	Input	9	NC	No connection			Shell	-	No connection		
Pin No.	Signal name	Contents	Channel	Input/Output																																																							
1	NC	No connection																																																									
2	RD1	Receive data	CH1	Input																																																							
3	SD1	Send data	CH1	Output																																																							
4	ER1	DR (6-pin) and internal connection	CH1																																																								
5	SG	Signal ground																																																									
6	DR1	ER (4-pin) and internal connection	CH1																																																								
7	RS1	Request to send	CH1	Output																																																							
8	CS1	Transmission enable	CH1	Input																																																							
9	NC	No connection																																																									
Shell	-	No connection																																																									

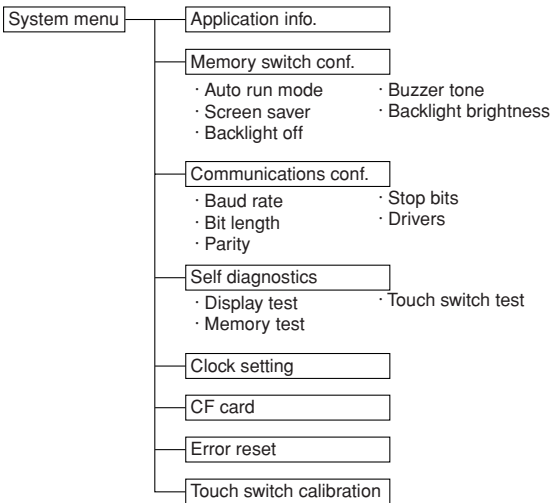
Communications (CH2) Interface	Communication standard	RS-485 equivalent (full duplex/half duplex)																																						
	Transmission distance	1000 m																																						
	Unit connection number	31 units																																						
	Transmission speed	4800, 9600, 19200, 38400, 57600 and 115200 bps																																						
	Connector	4 mm dia. terminal block																																						
		<table border="1"> <thead> <tr> <th>Pin No.</th> <th>Signal name</th> <th>Contents</th> <th>Channel</th> <th>Input/Output</th> </tr> </thead> <tbody> <tr> <td>1</td> <td>SDA2</td> <td>Send data (+)</td> <td>CH2</td> <td>Output</td> </tr> <tr> <td>2</td> <td>SDB2</td> <td>Send data (-)</td> <td>CH2</td> <td>Output</td> </tr> <tr> <td>3</td> <td>RDA2</td> <td>Receive data (+)</td> <td>CH2</td> <td>Input</td> </tr> <tr> <td>4</td> <td>RDB2</td> <td>Receive data (-)</td> <td>CH2</td> <td>Input</td> </tr> <tr> <td>5</td> <td>SG</td> <td>Signal ground</td> <td></td> <td></td> </tr> <tr> <td>6</td> <td>FG</td> <td>For frame ground relay</td> <td></td> <td></td> </tr> </tbody> </table>	Pin No.	Signal name	Contents	Channel	Input/Output	1	SDA2	Send data (+)	CH2	Output	2	SDB2	Send data (-)	CH2	Output	3	RDA2	Receive data (+)	CH2	Input	4	RDB2	Receive data (-)	CH2	Input	5	SG	Signal ground			6	FG	For frame ground relay					
Pin No.	Signal name	Contents	Channel	Input/Output																																				
1	SDA2	Send data (+)	CH2	Output																																				
2	SDB2	Send data (-)	CH2	Output																																				
3	RDA2	Receive data (+)	CH2	Input																																				
4	RDB2	Receive data (-)	CH2	Input																																				
5	SG	Signal ground																																						
6	FG	For frame ground relay																																						
Communications (CH3, CH4) Interface	Communication standard	RS-485 equivalent (half duplex)																																						
	Transmission distance	1000 m																																						
	Unit connection number	31 units																																						
	Transmission speed	4800, 9600, 19200, 38400 bps																																						
	Connector	3 mm dia. terminal block																																						
		<table border="1"> <thead> <tr> <th>Pin No.</th> <th>Signal name</th> <th>Contents</th> <th>Channel</th> <th>Input/Output</th> </tr> </thead> <tbody> <tr> <td>1</td> <td>DA3</td> <td>Send/receive data (+)</td> <td>CH3</td> <td>Input/Output</td> </tr> <tr> <td>2</td> <td>DB3</td> <td>Send/receive data (-)</td> <td>CH3</td> <td>Input/Output</td> </tr> <tr> <td>3</td> <td>DA4</td> <td>Send/receive data (+)</td> <td>CH4</td> <td>Input/Output</td> </tr> <tr> <td>4</td> <td>DB4</td> <td>Send/receive data (-)</td> <td>CH4</td> <td>Input/Output</td> </tr> <tr> <td>5</td> <td>SG</td> <td>Signal ground</td> <td></td> <td></td> </tr> </tbody> </table>	Pin No.	Signal name	Contents	Channel	Input/Output	1	DA3	Send/receive data (+)	CH3	Input/Output	2	DB3	Send/receive data (-)	CH3	Input/Output	3	DA4	Send/receive data (+)	CH4	Input/Output	4	DB4	Send/receive data (-)	CH4	Input/Output	5	SG	Signal ground										
Pin No.	Signal name	Contents	Channel	Input/Output																																				
1	DA3	Send/receive data (+)	CH3	Input/Output																																				
2	DB3	Send/receive data (-)	CH3	Input/Output																																				
3	DA4	Send/receive data (+)	CH4	Input/Output																																				
4	DB4	Send/receive data (-)	CH4	Input/Output																																				
5	SG	Signal ground																																						
		<p>ⓘ Precautions in Handling CH3 and CH4 are for RS-485 duplex communication. Dedicated output terminals (RSA and RSB) are required when the Mitsubishi CPU direct communication mode is designated.</p>																																						
System menu	Basically an application can make each setting but the setting can be changed by the Smart terminal.																																							
																																								
Application info.	Display built-in application file names and down-load dates																																							
Memory switch conf.	Automatic run start	Wait time till starting is set to find if the automatic run starts at power input																																						
	Screen saver start	Wait time till starting is set to find is screen saver starts to run																																						
	Automatic back light off	Wait time till starting is set to find if the back-light is automatically turned off.																																						
	Buzzer tone	Selection of high, medium and low is possible.																																						
	LCD backlight brightness adjustment	Adjust the brightness of the LCD backlight.																																						
Communications conf.	Set the transmission speed for communication port.																																							
Self-diagnostics	Display test	To confirm if LCD is damaged.																																						
	Memory test	Conduct test for internal memory.																																						
	Touch switch test	Conduct test for touch switch.																																						
Clock setting	Adjust the built-in clock.																																							
CF card	To format the CF card and copy the application data.																																							
Error reset	To clear the system error.																																							
Touch switch calib.	To adjust the EST touch switches.																																							

General specifications	Electrical specifications	Supply voltage	85 to 132Vac 50/60Hz 24Vdc $\pm 10\%$		
		Current consumption	AC power supply: 50VA or less DC power supply: 2A or less		
		Allowable instantaneous shut-down	20ms. or less (AC power supply)		
		Dielectric strength	AC power supply: 500Vac for 1 min. (between each signal wire and power input/FG terminal), 1500Vac for 1 min. (between power input and FG terminal) DC power supply: 500Vac for 1 min. (between each signal wire and power input/FG terminal), 500Vac for 1 min. (between power input and FG terminal)		
		Insulation resistance	10M Ω min. at 500Vdc between power input and FG terminals, and between each signal wire and power input/FG terminals		
		Grounding	Class 3 grounding		
	Environmental specifications	Ambient store temperature	-20 to +60°C		
		Ambient operating temperature	0 to 50°C		
		Store operating humidity range	30 to 85%RH (No condensation allowed) (However, the condition is the same as absolute humidity of 85% at 40°C under above 40°C temperature.		
		Ambient gas	No presence of corrosive gases		
		Vibration resistance	Conform to JIS C 0911. Subjected to 10 to 55 Hz vibrations in X, Y and Z axis directions at 9.8 m/s ² for 6 minutes of signal sweep and 2 hours in each axis direction		
		Shock resistance	Conform to JIS 0912: Acceleration 98 m/s ² for 20 ms max.		
		Noise resistance	AC power supply: $\pm 1200V$ DC power supply: $\pm 1000V$	50 ns to 1 μs (by power input and impulse noise simulator)	
		Protective structure	IP64 (dust and drip-proof)		
	Mechanical specifications	External dimensions	250 (H) \times 295 (V) \times 99 (D) mm		
		Weight	2.7 kg		
		Mounting	Vertical panel mounting by fixing from the rear side with metal fittings.		
		Cooling method	Natural cooling		
		Screw tightening torque	0.5N·m (recommended)	CH3, CH4, and 3 mm dia. terminal block	
		Screw tightening torque	1.2N·m (recommended)	Power supply, CH2, DO, 4 mm dia. terminal block, and back plate	
Metal fittings tightening		From no loose condition of metal fittings in place, make 1/2 to 1 turn further.			

Item	Name	Model No.	Qty	Item	Name	Model No.	Qty
Accessories	Instruction sheet	CP-UM-5229E	1	Replacement part	Backlight (before date code 0208)	ESTX955BL11	1
	Metal fittings	ESTX939FB00	4		Backlight (after date code 0212)	ESTX955BL12	1
Application software (separate order)	AP editor (CD-ROM) coping with Windows 98/Me/XP	ESTX240SWWEC000	1		Protective sheet (For white body)	ESTX955SS10	1
	DMC10 package (3.5 in. FD)	ESX220D5AE 3001	1		(For black body)	ESTX955SS20	1
Separate instruction sheet (separate order)	Instruction sheet hardware edition	CP-SP-1103E	1	Accessories	RS-232C cable (2 m) 9-9 pin	CBL232FFT02	1
					Battery	81446345-001	1
					Compact flash memory card 64 M bytes	SCF0640	1
					Adaptor for PC card conversion	SCFADP000	1

Model No. Configuration

Model No.	Specifications	Power supply	Memory card	CE marking
EST0555Z01 * EX00	TFT programmable display 10.4"-LCD, 256 colors, 640 x 480 dots	AV100V	Not provided.	Not provided.
EST0555Z01 * ES00		AV100V	Provided.	Not provided.
EST0555Z05 * EX00		DC24V	Not provided.	Not provided.
EST0555Z05 * ES00		DC24V	Provided.	Not provided.
EST0555Z05BEX0M		DC24V	Not provided.	Provided.
EST0555Z05BES0M		DC24V	Provided.	Provided.

* B: Black case W: White case

The model applicable to the CE marking is only a model having black case and 24Vdc specifications.

External Dimensions

(Unit: mm)

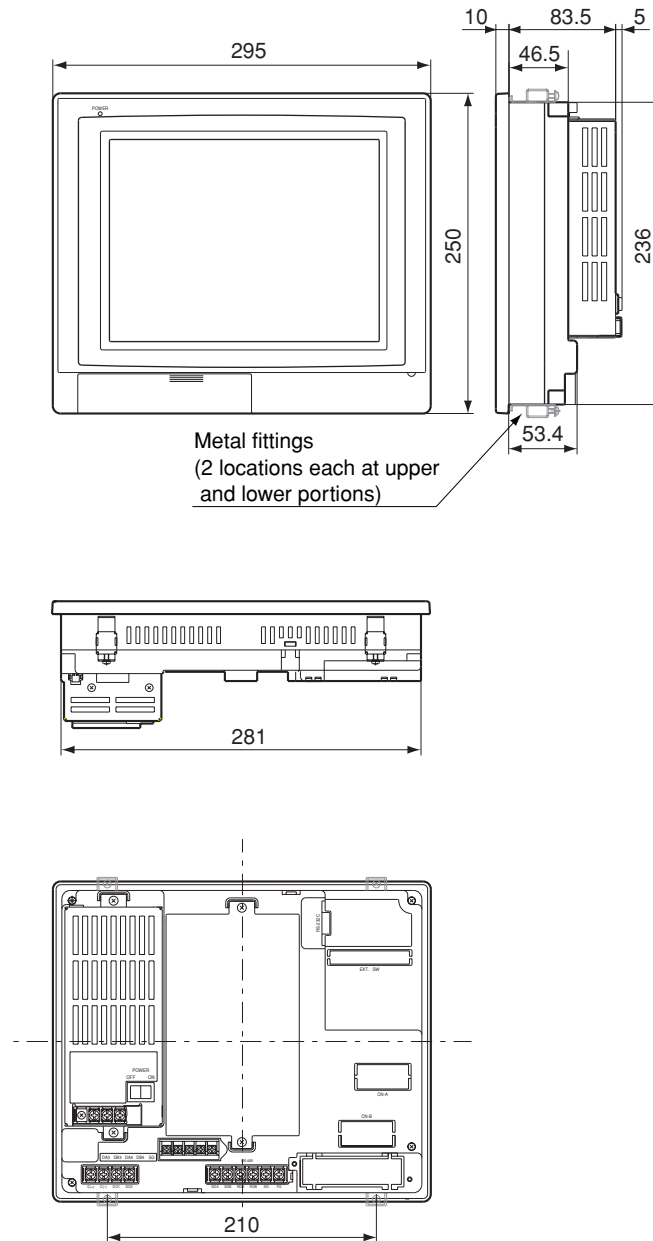

■ Panel Cut Dimensions

Cut the panel per the following dimensions and make the panel thickness as $t =$ a minimum of 1.6.

(Unit: mm)



■ Mounting

The Smart Terminal is positioned in place from the panel front. Fasten the screws by inserting the mounting metal fittings into the upper and lower body holes. Fix the body by turning additionally a half to one turn from the condition of the fittings being firmly in place.

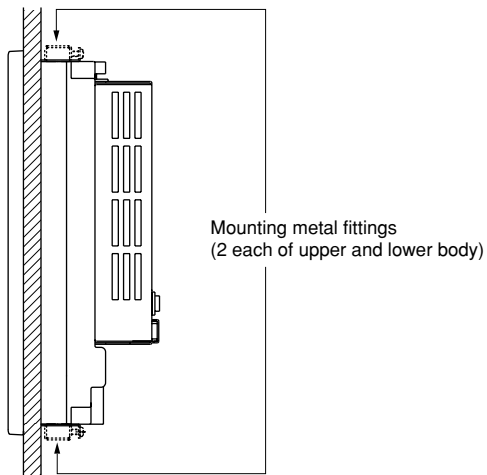

! Precautions in Handling

The body case may be deformed or damaged in the excessive tightening of the mounting screws.

* Windows98/Me/XP are the registered trademarks of Microsoft Corporation in the United States.



RESTRICTIONS ON USE

This product has been designed, developed and manufactured for general-purpose application in machinery and equipment. Accordingly, when used in applications outlined below, special care should be taken to implement a fail-safe and/or redundant design concept as well as a periodic maintenance program.

- **Units for concerning to control and safety of transportation vehicles (automobiles, trains and ships, etc.)**
- **Traffic control systems**
- **Safety equipment**
- **Anti-disaster systems, anti-crime systems**
- **Medical equipment (not specifically designed for life support)**

Never use this product in applications which require extremely high reliability, such as those outlined below.

- **Aeronautical machines**
- **Submersible repeaters**
- **Life support systems (medical equipment, etc.)**
- **Aerospace machines**
- **Nuclear reactor control systems**

Never use this product in applications where human safety may be put at risk.

Never use this product as a safety switch or as an emergency stop switch.

Special care should be taken to implement a fail-safe and/or redundant design which takes into account the possibility of operational delay, unit damage and malfunction of this product.

Specifications are subject to change without notice.

azbil

Yamatake Corporation Advanced Automation Company

1-12-2 Kawana, Fujisawa
Kanagawa 251-8522 Japan
URL: <http://www.azbil.com>

Printed in Japan. (H)
1st Edition: Issued in Aug., 2003

Printed on recycled paper.

(07)