

# SVP3000 Alphaplus

## Smart Valve Positioner with FOUNDATION™ fieldbus

### Model AVP303/AVP304

#### OVERVIEW

The SVP3000 Alphaplus model AVP303 is a FOUNDATION fieldbus equipped smart valve positioners.

The model AVP303 controls and manages the valve through Fieldbus.

The model AVP304 obtains a unique function that is realized by the hybrid technology. The model AVP304 adopts two signals, analog and FOUNDATION fieldbus, that the analog signal is for control loop and the FOUNDATION fieldbus is for diagnostic purpose.

Various diagnostic functions and the automatic configuration function of the SVP3000

Alphaplus, as well as PID function blocks, bring out real fieldbus advantages.

#### FEATURES

##### **Easy to use**

###### • Auto- setup

The auto-setup function is a fully-automatic configuration program that specifies the actuator and adjusts zero and span of the valve. The program can be run with the simple operation of an external switch so that the adjustments of the valve can be quickly and safely performed in hazardous areas.

##### **Valve diagnostic**

Following parameters can be monitored by Control Valve Maintenance Support System “Valstaff™”.

- Stick Slip
- Total Stroke
- Travel Histogram
- Cycle Count
- Shut-Off Count
- Max. Travel Speed

##### **High reliability**

###### • Positive seating

The positive seating function completely shut off the valve when the input signal is lower than that set by user. This allows full play to the shut-off capability of the valves.

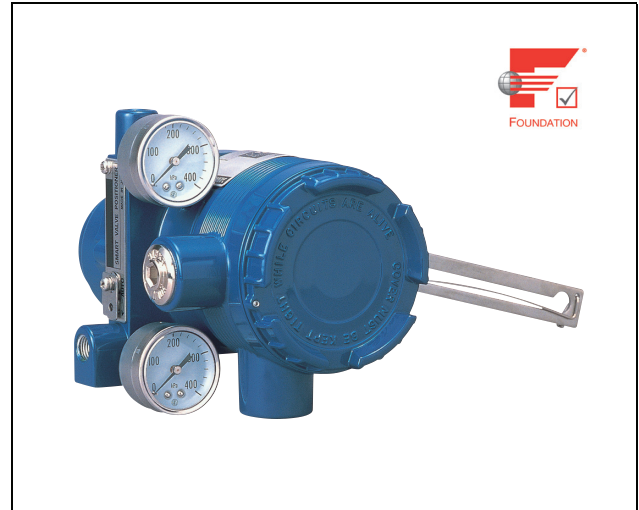

###### • Self-diagnostic

The self-diagnostic function provides the ability to check the status of the positioner and to alert the failure.

##### **Single model for multiple specifications**

SVP3000 Alphaplus' settings can be changed without any replacement of changing of parts. A single model can be modified to suit any application without any parts change.

- Flow characteristic: Linear, EQ%, Quick opening or user customized characteristics
- Actuator type: Double or single acting actuator (optional reversing relay required)

##### **FOUNDATION fieldbus Compliance**

The SVP is equipped with FOUNDATION fieldbus compliant PID function block. It offers most efficient loop on Fieldbus.

##### **China RoHS**

This device is used in the Oil & Gas, Petrochemical, Chemical, Pulp & Paper, Food & Beverage, Machinery, Steel/Metal & Mining, and Automobile industries and therefore does not fall under the China RoHS Legislation.

If this device is used in semiconductor manufacturing equipment, labeling on the device and documents for the China RoHS may be required. If such documents are required, consult a Yamatake representative.

**FUNCTIONAL SPECIFICATIONS****Applicable actuator**

- Single and double acting actuator
- Linear and rotary motion actuator

**Approvals****TIIS Flameproof approval**

Ex d IIC T6 Certificate No. TC16388

**KOSHA Flameproof approval**

Ex d IIC T6

**FM Explosionproof approval****Explosionproof**Class I, Division 1, Group A, B, C, D, T6 at  $-40^{\circ}\text{C} \leq T_a < 80^{\circ}\text{C}$ ; NEMA type 4X**Flameproof**Class I, Zone 1, AEx d IIC T6 at  $-40^{\circ}\text{C} \leq T_a < +80^{\circ}\text{C}$ ; IP66**Dust-ignition**Class II, III, Division 1, Group E, F, G, T6 at  $-40^{\circ}\text{C} \leq T_a < 80^{\circ}\text{C}$ ; NEMA type 4X

Installation should comply with NEC ANSI/NEPA-70

**KEMA/ATEX Intrinsically safe (FISCO) approval (Model AVP303 only)**

II 1 G Ex ia IIC T4

Certificate No. KEMA 04ATEX1183 X

IEC IP66

The barriers should be ATEX (FISCO) certified types and comply with the following condition as follows.

$$U_i = 17.5 \text{ V}, I_i = 380 \text{ mA}, P_i = 5.32 \text{ W}, C_i = 2.2 \text{ nF}, L_i = 0$$
**NEPSI Flameproof approval**

Ex d IIC TC, DIP A20 TA T6 IP66

Flameproof cable gland must be an approval model of NEPSI Ex d IIC.

**Output characteristics**

- Linear, Equal percentage, Quick opening
- Custom configurable - 15 segments

**Stem travel range**Feedback Lever Angle  $\pm 4^{\circ}$  to  $\pm 20^{\circ}$ **Bypass operation**

Auto/Manual external Switch (For single acting type only)

**Air supply pressure**140 to 700 kPa {1.4 to 7.0 kgf/cm<sup>2</sup>}**Air consumption**

at the stable output 50%

4 l/min(N) maximum at 140 kPa {1.4 kgf/cm<sup>2</sup>}5 l/min(N) maximum at 280 kPa {2.8 kgf/cm<sup>2</sup>}6 l/min(N) maximum at 500 kPa {5.0 kgf/cm<sup>2</sup>}10 l/min(N) maximum at 400kPa {4.0kgf/cm<sup>2</sup>}

for double acting type

**Maximum air deliver flowrate**110 l/min(N) at 140 kPa {1.4 kgf/cm<sup>2</sup>}250 l/min(N) at 400 kPa {4.0kgf/cm<sup>2</sup>}

for double acting type

**Output balanced pressure**55  $\pm$  5% for double acting type only**Lightning protection**

Peak value of voltage surge: 12 kV

Peak value of current surge: 1000A

**Vibration tolerance**

2G (5 to 400 Hz)

(with standard mounting kit on Yamatake HA actuator)

**Ambient temperature limits**Waterproof:  $-40^{\circ}\text{C}$  to  $+80^{\circ}\text{C}$ TIIS Flameproof:  $-20^{\circ}\text{C}$  to  $+55^{\circ}\text{C}$ KOSHA Flameproof:  $-20^{\circ}\text{C}$  to  $+55^{\circ}\text{C}$ FM Explosion proof:  $-40^{\circ}\text{C}$  to  $+80^{\circ}\text{C}$ 

KEMA/ATEX Intrinsically safe (FISCO):

 $-40^{\circ}\text{C}$  to  $+60^{\circ}\text{C}$ NEPSI Flameproof:  $-40^{\circ}\text{C}$  to  $+60^{\circ}\text{C}$ **CE conformity****Electromagnetic compatibility**

EN61326-1: 2006 (CE marking)

**Ambient humidity limits**

10% to 90% RH

**PERFORMANCE SPECIFICATIONS****Accuracy** $\pm 1\%$  F.S. ( $\pm 2.5\%$  with custom output characteristics)**Travel transmission accuracy** $\pm 1\%$  F.S. ( $\pm 2.5\%$  with output characteristics modification)**PHYSICAL SPECIFICATIONS****Enclosure rating**

JISC0920 watertight, NEMA type 4X, IP66

**Finish**

Baked acrylic

**Color**

Dark blue

**Material**

Cast aluminum

**Weight****For single acting type**

Without Pressure regulator with filter : 2.5 kg

With Pressure regulator with filter : 3.2 kg

**For double acting type**

Without Pressure regulator with filter : 2.8kg

With Pressure regulator with filter : 3.5 kg

## INSTALLATION

### Air connections

Rc1/4 or 1/4NPT internal thread

### Electrical connections

G1/2 or 1/2NPT

### Conditions of supply air (JIS C1805-1 (2006))

#### Particles

Maximum diameter 3μm

#### Oil mist

Less than 1 ppm at mass

#### Humidity of the air supply

The dew point should be at least 10°C lower than the temperature of this device.

## FIELDBUS SPECIFICATIONS

### Function blocks

PID function block ×2

AO function block ×1

AI function block ×1 (Model AVP304 only)

#### Period of execution

- PID function block: 125 ms
- AO function block: 75 ms
- AI function block: 75 ms

Standard parameters of FOUNDATION fieldbus

### Diagnostic function block

Yamatake unique parameters defined by device description

### Transducer block

Standard parameters of FOUNDATION fieldbus and Yamatake unique parameters defined by device description

### Resource block

Standard parameters of FOUNDATION fieldbus and Yamatake unique parameters defined by device description

### Trend object

Standard parameters of FOUNDATION fieldbus

### Alert object

Standard parameters of FOUNDATION fieldbus

### View object

Standard parameters of FOUNDATION fieldbus

### Link object

7 max.

### Network parameters

- Slot time V(ST): 5 to 100
- Max. Response Delay V(MRD):  $V(MRD) \times V(ST) \geq 20$  and  $V(MRD) \leq 11$
- Min. Inter-Pdu Delay V(MID): 10 to  $(V(MRD)-1) \times V(ST)$ , and  $V(MID) \leq 120$

### Number of virtual communication relationship

16 max.

### Supply voltage

9 to 32V (current 20 mA)

### Registration

Interoperability test ITK 4.6 approved.

## Typical installation

Figure 1 shows the wiring for the model AVP303 and Figure 2 shows the wiring for the model AVP304.

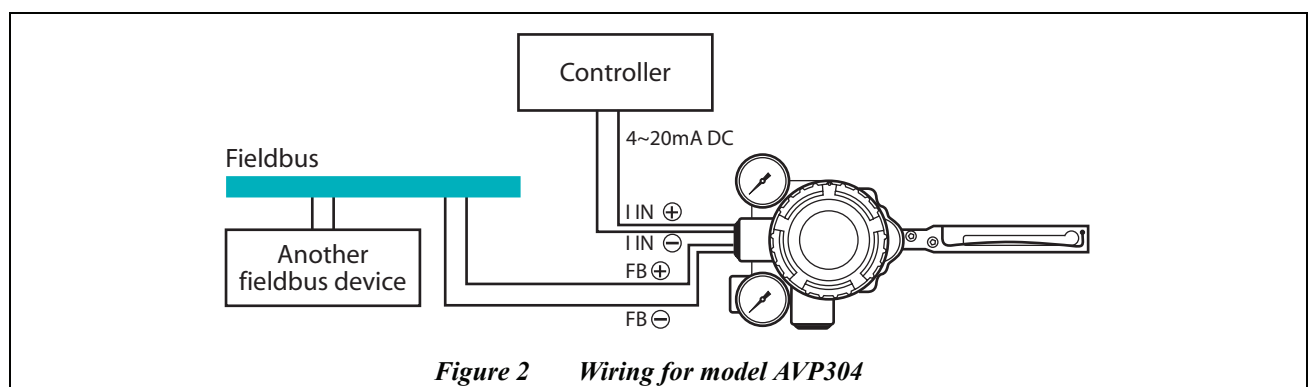
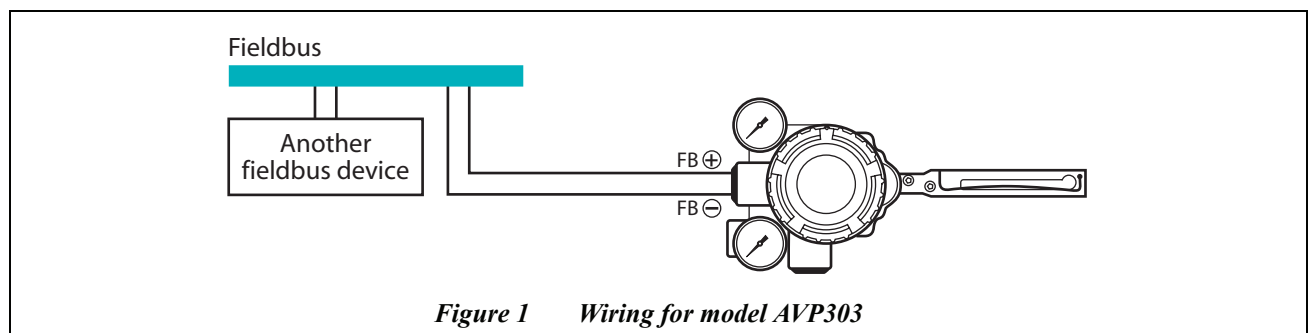

## MODEL SELECTION

Model No. **AVP303/AVP304** - Selection (1) (2) (3) (4) (5) - (6) (7) (8) (9) - Option (10)

- Note) \*1 One set of Flameproof cable gland will be attached for model AVP303, two sets are for model AVP304.  
 \*2 No domestic sales in Japan due to Non-SI unit.  
 \*5 Code "E" and "N" can not be selected simultaneously.  
 \*6 Code "F" and "G" can not be selected simultaneously.  
 In case of TIIS explosion-proof, the conduit adaptor shall be provided on the top of the flameproof cable gland.  
 \*7 In case of double acting actuator, a reversing relay unit is required.  
 \*11 Standard finish is equivalent to paint specifications Y138A. Corrosion-proof is equivalent to previous Y138B.  
 \*13 Select model AVP (integral type) only when the direction of drain of the pressure regulator with filter on the control valve is downward (ground).  
 \*14 If a mounting bracket is not required, select "XX".

	Connection	Air piping connection	Electrical connection	Mounting thread	Code
<b>(1)Structure</b>	Waterproof	Rc1/4	G1/2	M8	X
	Waterproof	1/4 NPT	1/2 NPT	5/16 - 18	P
	TIIS Flameproof with cable gland *1	Rc 1/4	G1/2	M8	E
	KOSHA Flameproof	Rc 1/4	G1/2	M8	S
	FM Explosionproof and Flameproof	1/4 NPT	1/2 NPT	5/16-18	F
	ATEX Intrinsically safe (FISCO) (Model AVP303 only)	1/4 NPT	M20 × 1.5	M8	L
	NEPSI Flameproof	1/4 NPT	1/2 NPT	5/16-18	B
<b>(2)Finish</b>	Standard (Baked acrylic) *11				S
	Corrosion-proof (Baked epoxy) *11				B
	Silver finish (Baked acrylic)				D
<b>(3)Positioner action</b>	Direct action - Air pressure increases with control signal increase				D
	Reverse action - Air pressure decreases with control signal increase				R
<b>(4)Supply air-pressure classification</b>	Air supply range	Pressure gauge scale	Max regulator setting		
	130<Ps≤150kPa {1.3<Ps≤1.5kgf/cm <sup>2</sup> }	200kPa {2kgf/cm <sup>2</sup> }	400kPa {4kgf/cm <sup>2</sup> }		1
	150<Ps≤300kPa {1.5<Ps≤3.0kgf/cm <sup>2</sup> }	400kPa {4kgf/cm <sup>2</sup> }	400kPa {4kgf/cm <sup>2</sup> }		2
	300<Ps≤400kPa {3.0<Ps≤4.0kgf/cm <sup>2</sup> }	600kPa {6kgf/cm <sup>2</sup> }	400kPa {4kgf/cm <sup>2</sup> }		3
	400<Ps≤450kPa {4.0<Ps≤4.5kgf/cm <sup>2</sup> }	600kPa {6kgf/cm <sup>2</sup> }	700kPa {7kgf/cm <sup>2</sup> }		4
	450<Ps≤700kPa {4.5<Ps≤7.0kgf/cm <sup>2</sup> }	1000kPa {10kgf/cm <sup>2</sup> }	700kPa {7kgf/cm <sup>2</sup> }		5
<b>(5)Scale unit (pressure gauge)</b>	kPa				A
	kgf/cm <sup>2</sup> *2				B
	MPa				C
	bar				D
	psi *2				E
<b>(6)Pressure regulator with filter</b>	No selection				X
	Model KZ03 pressure regulator with filter (mounted on positioner) *13				1
	Model KZ03 pressure regulator with filter (with bracket for separated mount)				2
<b>(7) Material of Bracket / Bolts</b>	No Selection *14				X
	Stainless steel				D
<b>(8)(9) Actuators (for bracket)</b>	No Selection *14				XX
	For single acting actuator				Refer to Table 1
	For double acting actuator				Refer to Table 2
<b>(10) Option (Plural selection available)</b>	No selection				X
	Universal elbow explosion-proof (SUS304 G1/2) 1 pc.				A
	Reversing relay for double acting actuator *7				W
	Stainless filter for KZ03 (pressure regulator with filter)				K
	2 pcs. of adapter for air piping connection (Rc1/4 to 1/4NPT) for single acting actuator *5				E
	3 pcs. of adapter for air piping connection (Rc1/4 to 1/4NPT) for double acting actuator*5				N
	1 pc. of adapter for electric connection (G1/2 to 1/2NPT) *6				F
	2 pcs. of adapter for electric connection (G1/2 to 1/2NPT) *6				G
	Sealing tape not permitted				J
Filter (screen for air-exhaust port)				H	

Configuration)

- Following shows default and optional settings of each configurable parameter.
- Output characteristic      Liner      EQ or QO can be ordered or set by user
  - Valve actuator              Direct (Plug above seat)      Reverse (Plug below seat) can be ordered or set

Table 1 Mounting bracket for single acting actuator

(8)(9) Mounting bracket for pneumatic actuators	Code
PSA1, PSA2, PSK1	YS
PSA3, PSA4 / VA1 to VA3 produced after Apr.'83 *8	YQ
PSA3, PSA4 for existing valves produced on/before 1999	YY
PSA6 / VA4 to VA6 produced after Apr.'83 *8	YL
PSA7	Y8
HA1	YA
HA2, HA3, HL2, HL3	YT
HA4, HL4	YN
HK1, VM1 *12	YK
VM12 for model VSP *13	YB
VR1	YV
VR2, VR3	YR
VR3H	Y6
RSA1	YF
RSA2	YU
GOM 83S, GOM 84S, GOM 103S	YG
GOM 124S	YM
VA1 - VA3 (for old-model motion connectors) Produced on/before Apr.'83 800-1, 800-3 *9	YW
VA4 - VA5 (for old-model motion connectors) Produced on/before Apr.'83 800-4, 800-5 *9	YJ
Motoyama Mfg. 2800 series 240, 280, 330, Nihon Koso A100 series 270, 320 *3	TA
Motoyama Mfg. 2800 series 400, 500S, 500L, Nihon Koso A100 series 400, 500 *3	TB
Motoyama Mfg. 2800 series 650S, 650L *3	TC
Motoyama Mfg. 2800 series 240, 280, 330 (with side manual)	TD
Motoyama Mfg. 2800 series 400, 500S, 500L (with side manual)	TE
Motoyama Mfg. 2800 series 650S, 650L (with side manual)	TF
Motoyama Mfg. 3800 series (multi-spring type) N24, N28, N33S	TJ
Motoyama Mfg. 2922 series (Gyrol-I) G.R.I 280H, 330H, 400HS, 400H, 500H	TL
Motoyama Mfg. 3993 series (Gyrol-II) 2911-1M series 280, 330, 400	TG
Nihon Koso 5100L series 240, 280 *3	TP
Nihon Koso 5200L series 218, 270, 350 *3	TR
Masoneilan 37, 38 series #9, #11 *3	MA
Masoneilan 37, 38 series #13 *3	MB
Masoneilan 37, 38 series #15, #18 *3	MC

Table 1 Mounting bracket for single acting actuator

(8)(9) Mounting bracket for pneumatic actuators	Code
Masoneilan 37, 38 series #15, #18 (with side manual)	MF
Masoneilan 35002 series Camflex II #41/2, #6, (Valve size 1 in. - 4 in.)	MG
Masoneilan type 35002 Camflex II #7 (Valve size 6 in. - 12 in.)	MH
Fisher 657, 667 series size 40	FB
Fisher 657, 667 series size 45, 50	FC
Fisher 657, 667 series size 60	FD
Tyco Flow Control Japan AK09S, AK12S, AK15S	KA
Tyco Flow Control Japan AG06S, AGN06S	KG
Tyco Flow Control Japan AG09S, AGN09S	KH
Tyco Flow Control Japan AG13S, AGN13S	KJ
Tyco Flow Control Japan AW13S	KV
Tyco Flow Control Japan AW17S	KW
Tyco Flow Control Japan AW20S	KT
KITZ B series BS-2, BSW-2	B2
KITZ B series BS-3, BSW-3, Hisaka TS-6	B3
KITZ B series BS-4, BSW-4	B4
KITZ B series BS-5, BSW-5	B5
KITZ B series BS-6, BSW-6	B6
Xomox (EL-O-MATIC) E25, 40, 65, 100, 200, 350	RA
Xomox (EL-O-MATIC) E600, 950, 1600, P2500, P4000	RB
Hisaka TS-1	H1
Hisaka TS-2	H2
Hisaka TS-3	H3
Hisaka TS-4, 5	H4
Tomoe Valve Z series Z-06S, 08S, 11S, 13S	EA
Tomoe Valve T-matic 3Q-1, 2, 3, 4	E3

Note) \*3 Select in the case of without manual handle or with manual handle mounted on top of the actuators.

\*8 Select "YW" or "YJ" for old-type motion connectors. (Produced on/before Apr.'83)

\*9 Consult with sales representative in case of no mounting hole on the side of valve yoke.

\*12 In case "VM" type actuator is required following conditions, 1. select model "VCT" for the body, 2. the existing positioner should be HEP or VPE, 3. yoke should be model HK. If another spec. is required, contact your sales representative.

\*15 For model VSP (PVC body), an additional support bracket is required for the AVP.

Table 2 Mounting bracket for double acting actuator

(8)(9) Mounting bracket for pneumatic actuators		Code
VP5, 6	*7	Y1
VP7	*7	Y7
SLOP560, 1000, 1000X	*7 *16	Y2
SLOP1500, 1500X	*7 *16	Y3
DAP560, 1000, 1000X	*7 *16	Y4
DAP1500, 1500X	*7 *16	Y5
Tyco Flow Control Japan AK09, AK12, AK15	*7	KA
Tyco Flow Control Japan AG06, AGN06	*7	KG
Tyco Flow Control Japan AG09, AGN09	*7	KH
Tyco Flow Control Japan AG13, AGN13	*7	KJ
Tyco Flow Control Japan AW13	*7	KV
Tyco Flow Control Japan AW17	*7	KW
Tyco Flow Control Japan AW20	*7	KT
KITZ B series B-2	*7	B2
KITZ B series B-3	*7	B3
KITZ B series B-4	*7	B4
KITZ B series B-5	*7	B5
KITZ B series B-6	*7	B6
Xomox (EL-O-MATIC) E25, 40, 65, 100, 200, 350	*7	RA
Xomox (EL-O-MATIC) E600, 950, 1600, P2500, P4000	*7	RB
Tomoe Valve Z series Z-06, 08, 11, 13	*7	EA
Tomoe Valve T-matic 3I-1, 2, 3, 4	*7	E3
T. V. VALVE AT4-80	*7	V1
T. V. VALVE AT4-100	*7	V2
T. V. VALVE AT4-120	*7	V3
T. V. VALVE AT4-150	*7	V4
T. V. VALVE AT4-180	*7	V5

Note) \*7 In case of double acting actuator, a reversing relay unit required.

\*16 Contact a sales representative if a bracket for model VFR (FloWing) or butterfly valve is required.

Table 3 Standard travel range and accuracy

Actuator	Travel (mm)	Accuracy [% F.S.]
PSA1, 2	14.3, 20, 25	1
PSA3, 4	20, 38	1
HA1	6, 8, 10	3
	14.3, 25	1
HA2	10	3
	14.3, 25, 38	1
HA3	14.3	3
	25, 38, 50	1
HA4	14.3	3
	25, 38, 50, 75	1
VA5	25, 37.5, 50, 75, 100	1
VA6	14.3	3
PSA6, 7	25, 37.5, 50, 75, 100	1
HK1	10	3
PSK1	19	1

### DIMENSIONS

For single acting actuator without pressure regulator with filter [Unit: mm]

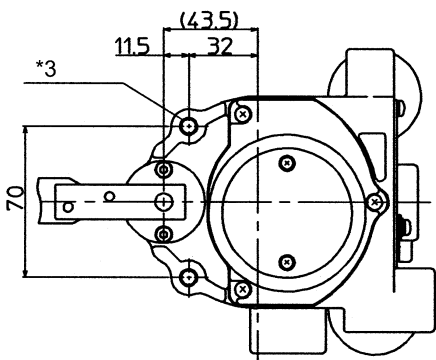
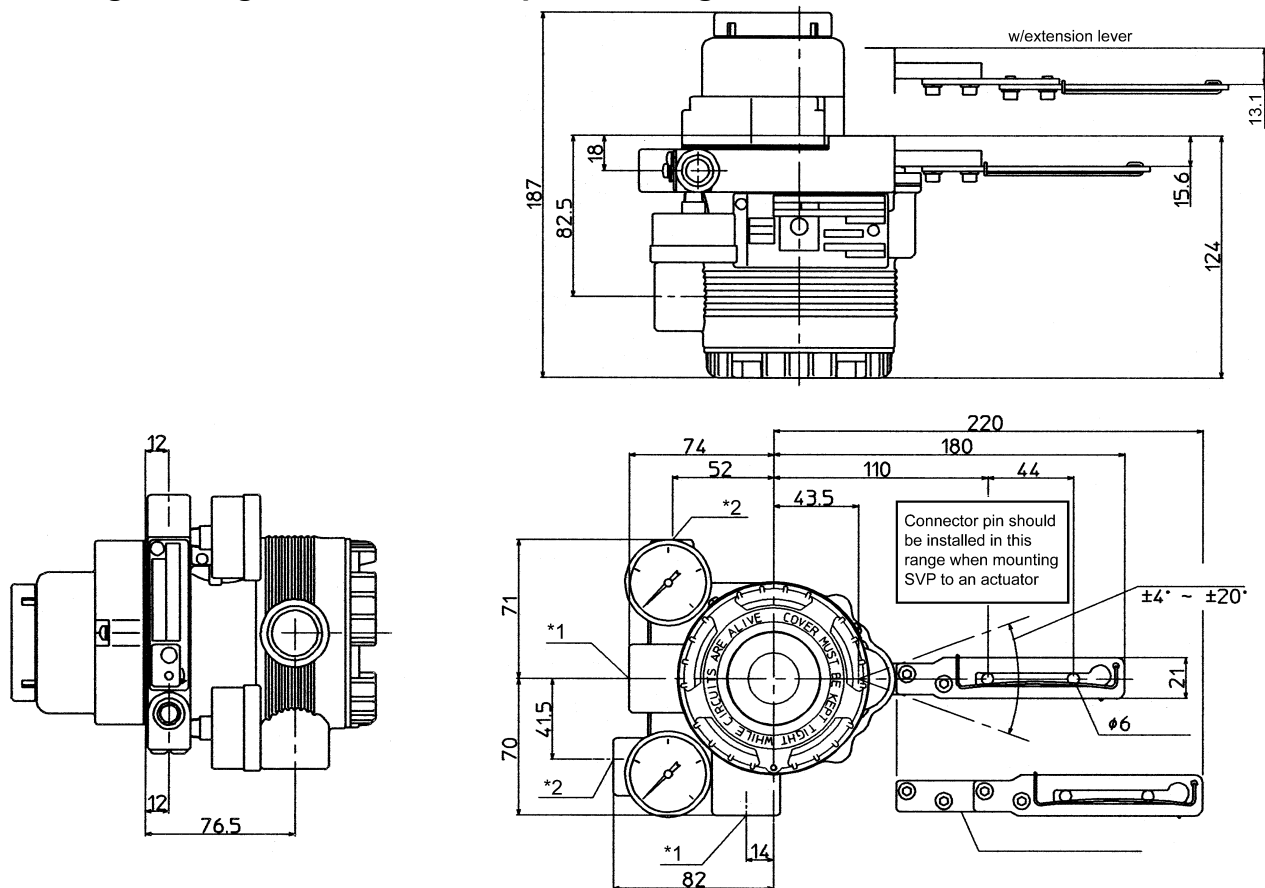

~Mounting plate reference dimension~

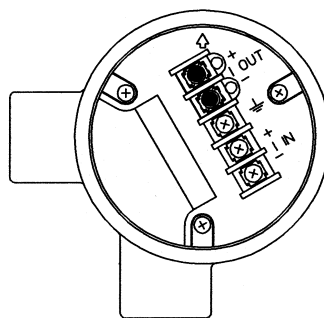

Terminal connections  
Terminal screw size M4

Extension lever	Actuator model	Code
No	PSA1, 2, PSK1	YS
	HA1	YA
	HA2, 3	YT
	HK1	YK
Yes	PSA3, 4	YQ
	VA1 to 3	YQ
	PSA6	YL
	PSA7	Y8
	HA4	YN
	VA4 to 6	YL
	VR1	YV
	VR2, 3	YR
	GOM83S, 84S, 103S	YG
	GOM124S	YM

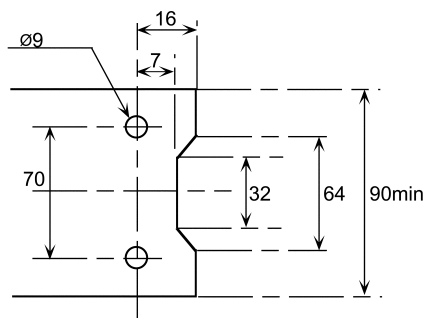

Type of protection	Conduit entry	Air piping connection	Mounting threads
Water-proof/THS and KOSHA Flameproof	G1/2	Rc1/4	M8
Water-proof/FM Flameproof/NEPSI Flameproof	1/2NPT	1/4NPT	5/16-18UNC
ATEX Intrinsically safe (FISCO)	M20 × 1.5	1/4NPT	M8
Parts on drawing	*1	*2	*3

For single acting actuator with pressure regulator with filter [Unit: mm]

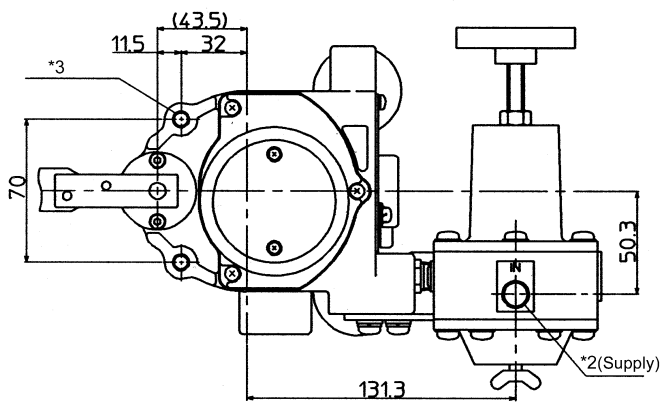
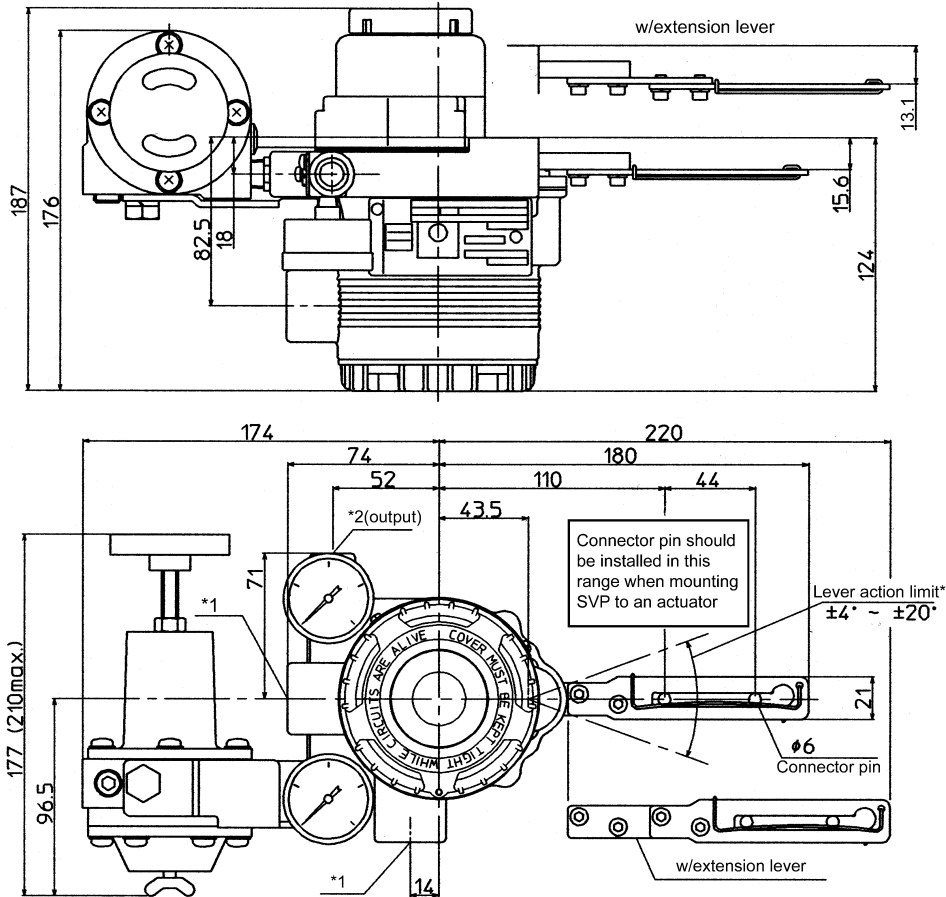

Extension lever	Actuator model	Code
No	PSA1, 2, PSK1	YS
	HA1	YA
	HA2, 3	YT
	HK1	YK
Yes	PSA3, 4 VA1 to 3	YQ
	PSA6	YL
	PSA7	Y8
	HA4	YN
	VA4 to 6	YL
	VR1	YV
	VR2, 3	YR
	GOM83S, 84S, 103S GOM124S	YG YM

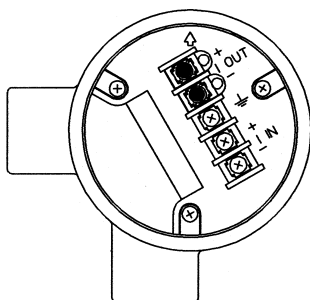

Type of protection	Conduit entry	Air piping connection	Mounting threads
Water-proof/THIS and KOSHA Flameproof	G1/2	Rc1/4	M8
Water-proof/FM Flameproof/NEPSI Flameproof	1/2NPT	1/4NPT	5/16-18UNC
ATEX Intrinsically safe (FISCO)	M20 × 1.5	1/4NPT	M8
Parts on drawings	*1	*2	*3

For double acting actuator with reversing-relay type

With pressure regulation with filter

[Unit: mm]

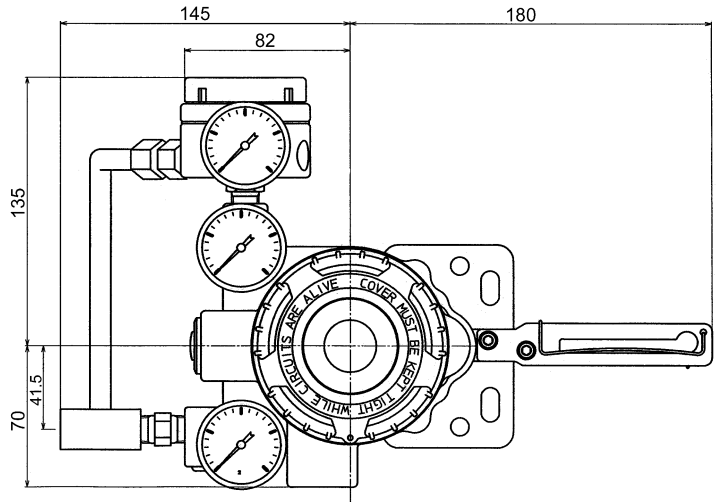
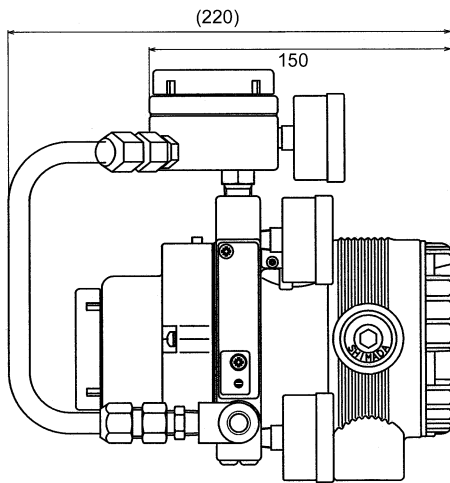

With pressure regulator with filter

[Unit: mm]

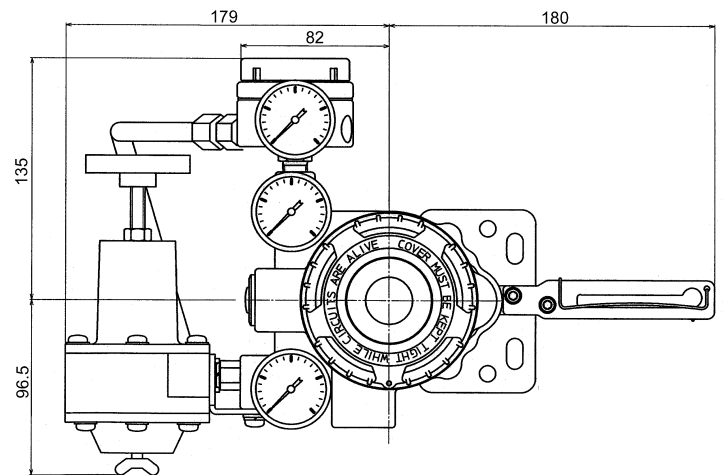
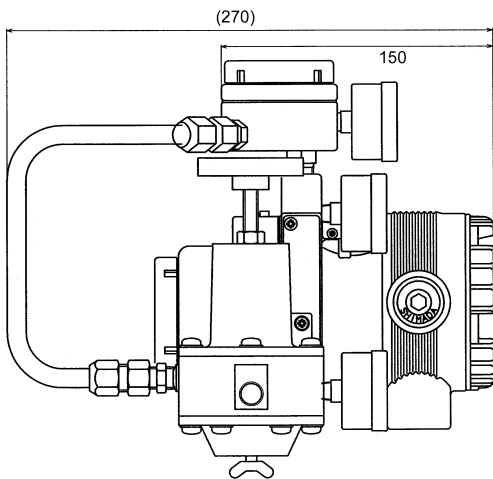

Note

Note

*Specifications are subject to change without notice.*

**azbil**

**Yamatake Corporation**  
**Advanced Automation Company**

1-12-2 Kawana, Fujisawa-shi  
Kanagawa-ken 251-8522 Japan

**URL:**<http://www.azbil.com>

*No part of this publication may be reproduced or duplicated without the prior written permission of Yamatake Corporation.*

Nov. 1999–Y/Y  
Apr. 2011 (rev.12)–Y/Y