



# Control Valve Maintenance Support System Valstaff Application for HART System

## Model VMS102

### OVERVIEW

The control valve maintenance support system, Valstaff, is a system that supports decision-making necessary for control valve maintenance and promotes the efficiency of maintenance operation. Communicating with the control valve, on which the smart valve positioner is mounted, the system realizes the following functions.

- Information on the operating status of the control valve is collected during the plant operation, and this data is processed, saved and managed by the Valstaff application to predict progress of the control valve deterioration and to judge for abnormalities.
- A request for performance test is transmitted from the Valstaff application, and the responses are then recorded to quantify performances of the control valve.
- The smart valve positioner is easily adjusted and set from the Valstaff application and this information is maintained by the application.
- Information on the control valve maintenance is electronically and centrally managed.

The Valstaff HART system adopts the HART protocol for its communication technology. The system is comprised of a smart valve positioner, host applications and HART-related equipment that support the protocol.

### FEATURES

#### **Combination with 4-20 mA analog instrumentation system**

The HART protocol is a communication technology that superimposes digital signals over 4-20 mA analog instrumental signals. This means that this system can flexibly be added to an existing control system, and maintenance operation can be performed utilizing the system.

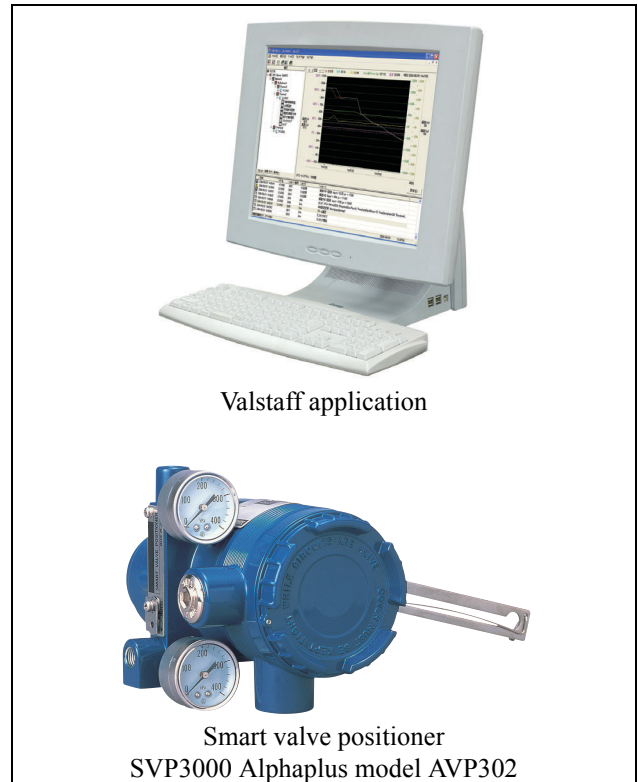

Valstaff application

Smart valve positioner  
SVP3000 Alphaplus model AVP302

#### **Networking**

Using the HART multiplexer, networking between multiple smart valve positioners and PCs with Valstaff applications installed can be established. This allows periodic monitoring of control valves, and running and recording of performance test that are programmed beforehand smoothly.

#### **Operation by one-to-one communication**

Using a HART modem, communications between smart valve positioners and PCs on which the Valstaff application is installed can be established on the analog output lines of the existing control system. This enables step-by-step introduction of the system, i.e., the effectiveness of this system can be checked in the operation, which is based on the one-to-one communication at an early stage, and networking can be deployed at a later stage.

**System configuration**

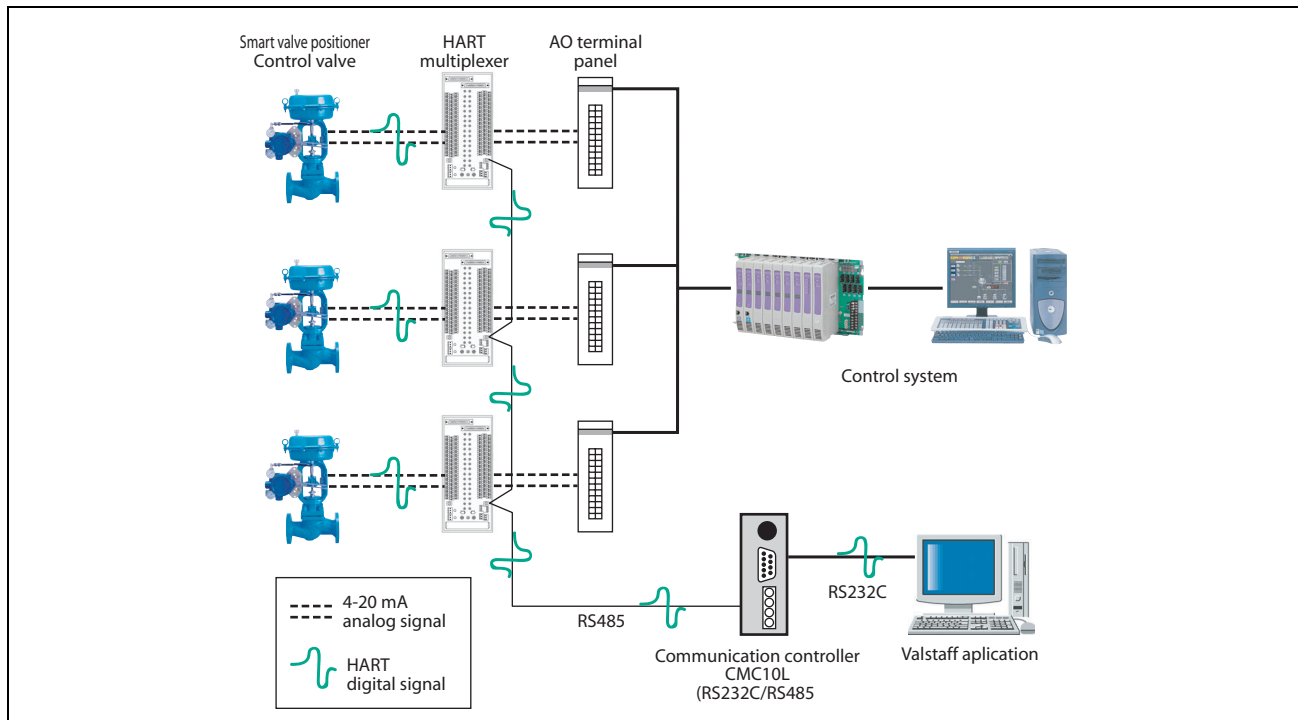

**Figure 1** System configuration example using HART multiplexer (connected in series)

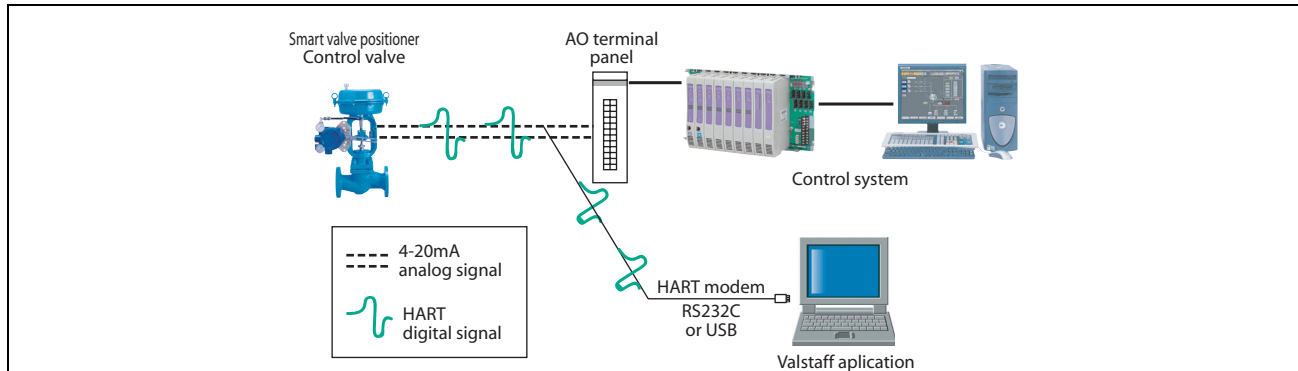

**Figure 2** System configuration using HART modem

**Soft ware mode**

**Operation Setup mode**

In Operation Setup mode, various types of information necessary for maintenance operation are registered and organized.

**Monitoring mode**

In Monitoring mode, transition of diagnostic parameters is checked by periodically communicating with smart valve positioners during plant operation.

**Test mode**

In Test mode, performance test commands are transmitted to smart valve positioners and their responses are received during plant shutdown.

**SVP configuration / Calibration mode**

In SVP configuration / Calibration mode, smart valve positioners are configured and calibrated during plant shutdown.

## FUNCTIONS

The following functions are available for each software mode.

### Functions of Operation Setup Mode

#### ■ Password setting

Taking into account how the plant operation is affected by a certain Valstaf operation, the user levels are preset on the Valstaf system. The user levels can be controlled with passwords to maintain security of the system operation.

#### ■ HART tag commissioning

Before starting the operation of Valstaf, this function checks whether tag numbers registered for the smart valve positioner and for Valstaf match. System setting errors can be eliminated by this function.

#### ■ Control valve specification management

Control valve specifications managed by Valstaf are saved in the database using this function. The saved specification data can be referenced, if necessary, during the monitoring mode or the test mode.

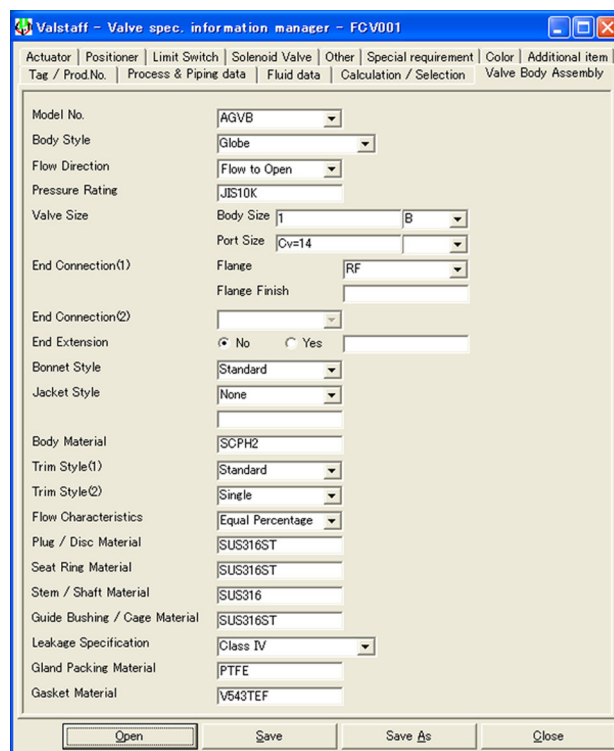

Figure 3 Control valve specification management window

#### ■ Alarm setting

This function is used to set whether or not alarms are needed upon detection of certain data in the monitoring mode, and to set their threshold values.

#### ■ Maintenance importance level registration

The maintenance importance levels set for individual control valves can be reflected onto Valstaf, taking into account process severities, degree of impact on plant operation, etc. These levels can be referenced during operation in the monitoring mode or when alarms are set up, thus providing support when responding to progressing errors or generated alarms in accordance with the importance levels.

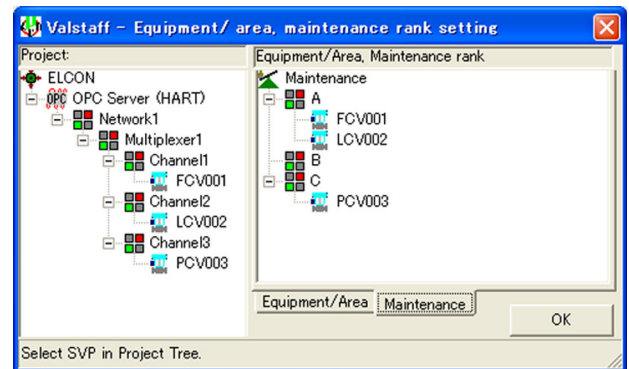

Figure 4 Importance level registration window

#### ■ Equipment/area information registration

Geographical information covering equipment installed and area information inside the equipment can be reflected onto Valstaf. Such information can be referenced during operation in the monitoring mode or when alarms are set up, thus providing support when responding to progressing errors or generated alarms by referring to geographical conditions.

### Functions of Monitoring Mode

#### ■ Displaying diagnostic parameters

Diagnostic parametric data held by smart valve positioners can be loaded to Valstaf applications during plant operation, and then graphically displayed using this function.

Deterioration progress and occurrence of errors can be predicted during plant operation by the Valstaf application.

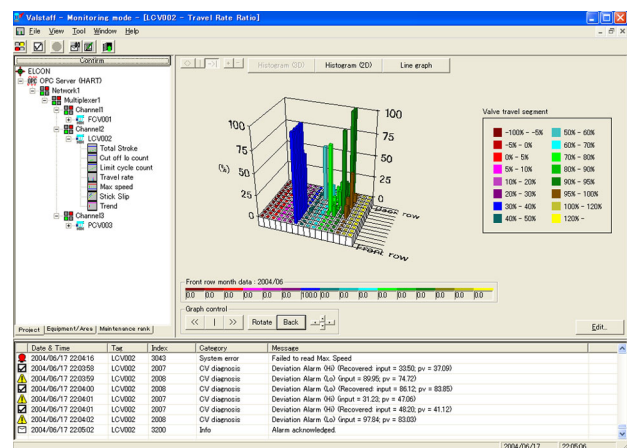

Figure 5 Displaying diagnostic parameters

#### ■ Setting alarm for diagnostic parameters

An alarm can be generated on Valstaf when data is detected that exceeds the preset threshold value of a diagnostic parameter using this function. This data is used as reference data for daily maintenance. In addition, the system can call and refer to the control valve specification information and importance level information registered in the operation setup mode described in [1], and parameter information of smart valve positioners, as needed, during operation in the monitoring mode.



## **SPECIFICATIONS**

### **Application specifications**

<b>Maximum number of HART multiplexer connections</b>	Up to 31 units by RS485 multi-drop (When PEPPERL + FUCHS Elcon's MUX 2700-G is used)
<b>Maximum number of smart valve positioner connections</b>	128 (If your system requires more than 128 units, please consult us.)
<b>Update cycles of diagnostic parameters</b>	Stick slip diagnostic algorithm: 400 sec.
	Total Stroke % parameter : 1 day
	Max. Travel Speed parameter : 1 day
	Shut Off Count parameter : 1 day
	Cycle Count parameter : 1 day
	Travel Histogram : 1 month
	SP, valve travel, EPM drive signal, SVP internal temperature trend: 4 seconds
<b>Performance test data sampling cycle</b>	83.3 msec.
<b>RS232C communication baud rate</b>	9600 bps to 38.4 kbps
<b>Data storage format</b>	CSV file
<b>Data backup</b>	Possible in offline status
<b>Data load</b>	Possible in offline status
<b>Time synchronization with smart valve positioner</b>	PC clock data is reflected onto smart valve positioners when: - PC time is manually changed, - Diagnostic parameter/alarm is read, or - Parameters are read/written.
<b>Information system networks</b>	Not supported.
<b>Copy protect</b>	USB port insertion type hardware license key system
<b>Related software</b>	HART OPC server (attached to Valstaff applications) License key driver (attached to Valstaff applications)

### **Applicable smart valve positioners**

<b>Model No.</b>	<b>Remarks</b>
AVP302	Software Ver.3.D or later (Field device revision 2 or later)
AVP202	
SVX102	Software Ver.4.D or later (Field device revision 2 or later)

For detailed specifications of smart valve positioners, refer to the specification sheets of the following relevant products.

- Model AVP302: SS2-AVP302-0100
- Model AVP202: SS2-AVP202-0100
- Model SVX102: SS2-SVX100-0100

**PC specifications**

<b>Model</b>	DOS/V machine
<b>CPU</b>	Pentium 4 1.0 G Hz or higher
<b>RAM</b>	256 MB or more
<b>Required hard disk capacity</b>	For Valstaff installation: 12 MB For saving diagnostic data per unit: 1 MB/year For saving trend data: 5 GB/year
<b>Required hardware</b>	CD-ROM drive
	USB connection removable HDD (for data backup/load)
	Color monitor (1024 ´ 768 pixels or more, 65536 display colors or more)
	RS232C port (for communication by HART multiplexer and HART modem)
	USB port (for communications via HART modem, and license key insertion) 1 port (HART communication is carried out via the RS232C port.) 2 ports (HART communication is carried out via a USB port.) <i>Note) HART modem cannot be connected via a USB hub.</i>
<b>Operating system</b>	Microsoft Windows XP Professional SP2 / Windows XP Home Edition SP2

**Related equipment**

**- HART multiplexer**

<b>Manufacturer</b>	<b>Product name, model, etc.</b>	
PEPPERL + FUCHS Inc. / Elcon	HART multiplexer module	MUX2700-G (recommended)
	Terminal board	HPSM/32/TB-02/HF16 or 32 (recommended) (General type, HART filter built-in type) HPSM/32/MM-01 (Compact type, without HART filter)

Refer to the reference materials on our selected products for details.

**- HART modem**

<b>Manufacturer</b>	<b>Product name, model, etc.</b>
MACTek Corporation	Model 010001 (RS-232C connection type, recommended)
	Model 010031 (USB connection type)

**- RS232C/485 converter**

<b>Manufacturer</b>	<b>Product name, model, etc.</b>
Yamatake	Communication controller CMC10L

Refer to the Specification Sheet CP-SS-1776 for details.

Note

HART is a registered trademark of HART Communication Foundation.  
Windows and MS are registered trademarks of Microsoft Corporation in the USA.  
Pentium is a registered trademark of Intel Corporation in the USA.  
All other brand and product names shown are trademarks of their respective owners.

*Specifications are subject to change without notice.*

**Yamatake Corporation**  
**Advanced Automation Company**

1-12-2 Kawana, Fujisawa-shi  
Kanagawa-ken 251-8522 Japan

**URL:**<http://www.azbil.com>

*No part of this publication may be reproduced or duplicated without the prior written permission of Yamatake Corporation.*

**azbil**

Oct. 2009 (rev.3)–Y/Y