

User Terminal

Neoplate (for IVC/ IFC/ Microstat)

QY7290

General

The QY7290 Neoplate is a user terminal for use with specific Azbil Corporation controllers. Neoplate enables operations of local controllers IFC (Intelligent FCU Controller) and IVC (Intelligent VAV Controller) and adjustment of the Microstat FCU (Fan Coil Unit) controller.

Neoplate has controls for such operations as air conditioning ON/OFF, setting of temperature and control of fan speed.



Features

- 1) Designed to look like regular lighting switch and ensures complete compatibility with any interior design.
- 2) Metal and plastic models available.
- 3) Temperature setpoint change based on either absolute value, relative value or perception of temperature.
- 4) Simple wiring with modular connectors for easy installation.

Models

Model No.	Material	Indication lamp	Setpoint	Fan speed	Logo	Description
QY7290						Neoplate (For IVC/IFC/ Microstat)
	A					Resin (color: white)
	B					Metal (corrosion resistant aluminum)
	C					Resin (color: whitish oak)
	D					Resin (color: canadian walnut)
		3				W/o indication lamp
		4				Indication lamp (note:1, 2)
			0			W/o setpoint adjustment (with air conditioning switch) (note:3, 4)
			1			Absolute value set
			2			Relative value set
			3			Perception of temperature
				0		W/o fan ON/OFF, speed control
				1		Air-conditioning switch (note:3)
				2		L / M / H switchover
				3		OFF / L / M / H switchover
					0	W/o logo
					1	Logo

Note 1: Indication lamp illuminates upon power supply to fan coil units.

Note 2: Setpoint for indication lamp model <QY7290*4***> is by absolute value and can be used only with fan speed changeover operation OFF/L/M/H switch model <QY7290*413*>.

Note 3: For the no-settings (with air-conditioning switch) model (QY7290**0**), the air-conditioning switch only model (QY7290**01*) or the L/M/H switchover model (QY7290**02*) can be selected.

Note 4: Air-conditioning switch has LED indicator to illuminate.



Safety Instructions

Please read instructions carefully and use the product properly. Please keep this instruction on hand for reference at any time.





Usage Restrictions

This product is targeted for general air conditioning. Do not use this product in a situation where human life may be affected. If this product is used in clean rooms or places where reliability or control accuracy is particularly required, please contact Azbil Corporation's sales representatives. Azbil Corporation bears no responsibility for any benefit, or lack of benefit, derived from the operation by the customer.

WARNING

-  Disconnect power supply before beginning wiring to prevent electrical shock or equipment damage.
-  Do not remove or dissolve the casing except for wiring or parts replacement. Equipment damage or electrical shock may result.
-  Check for loose wiring, to prevent heat generation or equipment damage.

CAUTION

-  Installer must be a trained, experienced service technician.
-  Check the ratings given in this instruction to prevent equipment damage.
-  Check the environment given in this instruction to prevent equipment damage.
-  All wiring must comply with local codes and ordinances.

Specifications

Common specifications

Item	Specifications
Ambient operating conditions	Temperature: 0 to 40 °C Humidity: 10 to 90 % RH (non-condensing) Vibration: 1.96 m/s ² (10 to 60 Hz)
Transport/storage conditions:	Temperature: -20 to 60 °C Humidity: 5 to 90 % RH (non-condensing) Vibration: Storage: 3.23m/s ² (10 to 150 Hz) Transport: 9.8m/s ² (10 to 150 Hz) (packaged)
Insulation resistance	Air-conditioning switch: 500 V DC, 20 MΩ min. Temperature adjustment: 500 V DC, 100 MΩ min. Fan speed switch: 500 V DC, 100 MΩ min. Indication lamp: 500 V DC, 100 MΩ min.
Dielectric strength	Air-conditioning switch: 500 V AC for one minute (Leak current: max. 5 mA) Temperature Adjustment: 500 V AC for one minute (Leak current: max. 5 mA) Fan speed switch: 1500 V AC for one minute (Leak current: max. 1 mA) Indication lamp: 1500 V AC for one minute (Leak current: max. 1 mA)
Installation	Wall-mount
Wiring	No fan speed switch (QY7290*3*0*, QY7290*3*1*): LAN cable EIA-568 compiled category 5 ϕ0.5 x 4P Fan speed switch (QY7290***2*, QY7290***3*): Equivalent to CVV2.0mm ² : For fan speed switch LAN cable EIA-568 compiled category 5 ϕ0.5 x 4P : For air-conditioning switch LAN cable EIA-568 compiled category 5 ϕ0.5 x 4P (using adapter) : For temperature setting
Wiring length	Maximum 50 m
Wiring type	Modular connect system (no fan speed switch: QY7290*3*0*, QY7290*3*1*) Lead wire (with fan speed switch: QY7290***2*, QY7290***3*) Lead wire length: 300 m Lead wire specifications: 105 °C heat resistance 300 V vinyl chloride wire
Accessories	Mounting screw M4, 8 mm long (2 pieces)

Materials

Parts	QY7290A,C,D	QY7290B
Base / cover	ABS resin UL94V-0	—
Setpoint knob	ABS resin UL94V-0	
Plate	—	Corrosion resistant aluminum
Mounting bracket	—	Fusion zinc gilt plate SGCC t1.2
Printed circuit board	Epoxy-lamination (glass included) t1.6	

Air-conditioning switch

Item	Specifications
Type	Momentary, normally-open contact, 1 circuit (with LED)
LED rating	Current: 10 mA Voltage: 2.1 V
Contact rating	12 V DC/1 VA max. (Resistive load)

Temperature adjustment

Item	Specifications
Setpoint range	15 to 30 °C (absolute: QY7290**1*) -3 to +3 °C (relative: QY7290**2**) COOL to WARM (± 3 °C) (perception of temperature: QY7290**3**)
Power rating	1.0 W
Rotation limits	180° ± 5°
Resistance	Nominal 1 kΩ

Fan speed control switch

Item	Specifications
Switch rating	Resistive load; 6A max., 125 V AC Inductive load: 3A max., 125 V AC (cos Φ 0.6)
Switch type	Rotary (3 -circuit, 3-position: QY7290***2*) (3 -circuit, 4 -position: QY7290***3*)

Indication lamp

Item	Specifications
Kind	Neon indication lamp (orange)
Rated current/voltage	1.4 mA, 125 V AC ± 10 %
Display	OFF: fan coil unit OFF ON: fan coil unit ON

- External View

The external view of QY7290***1 is identical to the following figure with logo.
QY7290C, D*** is identical to QY7290A**** in shape. But color is different.

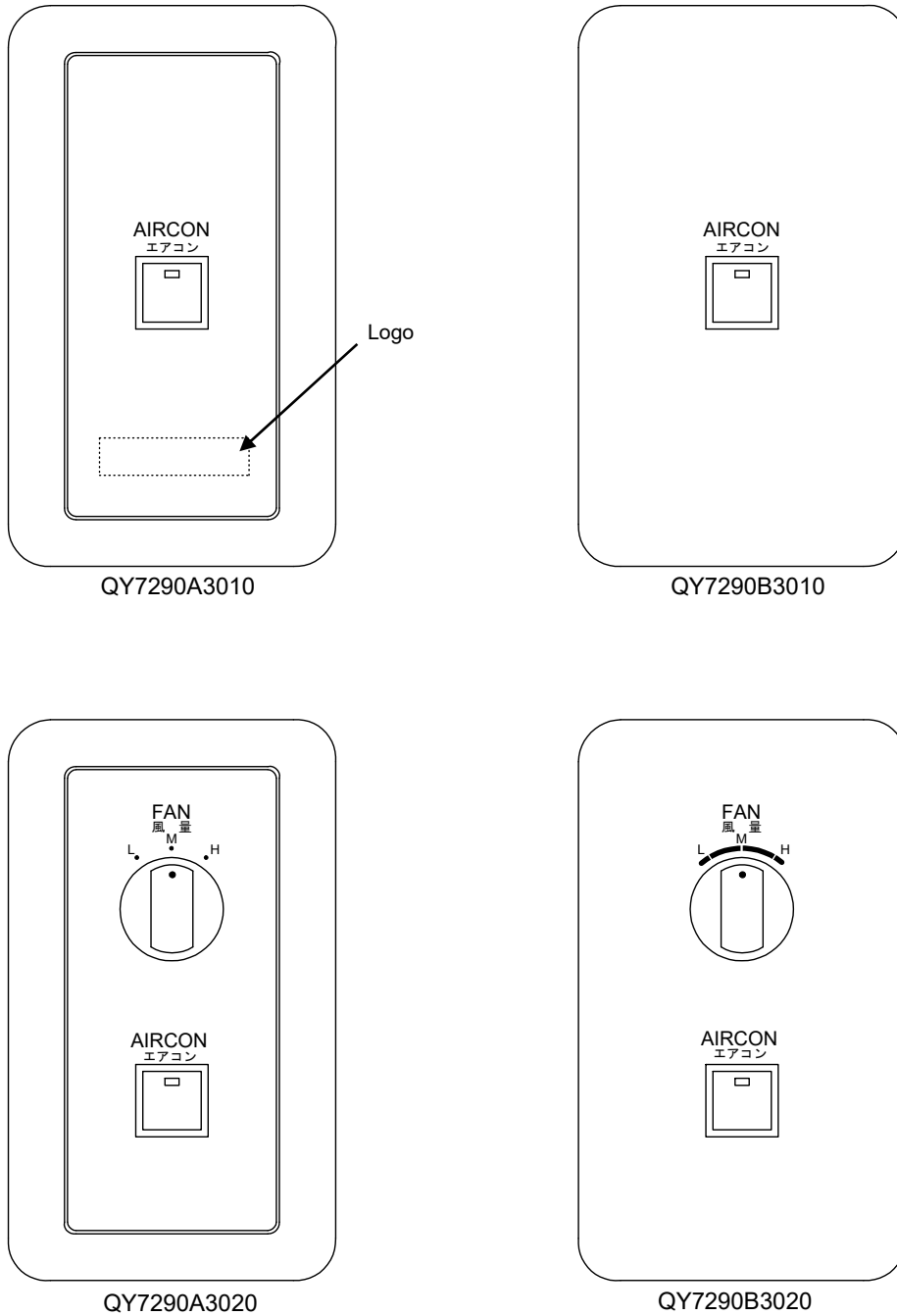

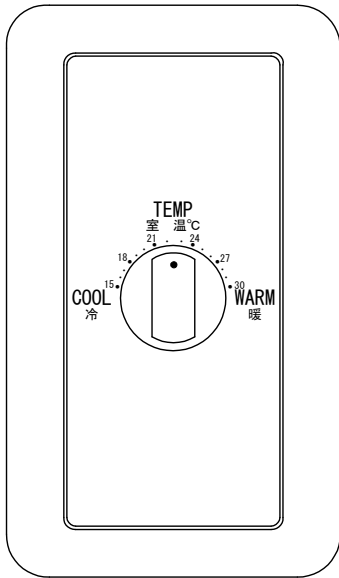

QY7290A3100

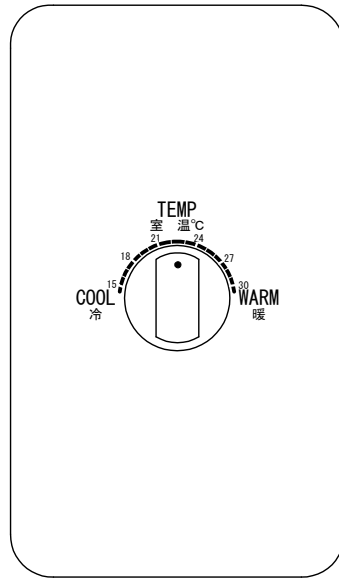

QY7290B3100

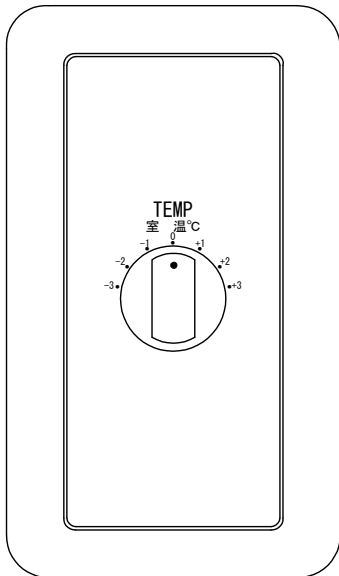

QY7290A3200

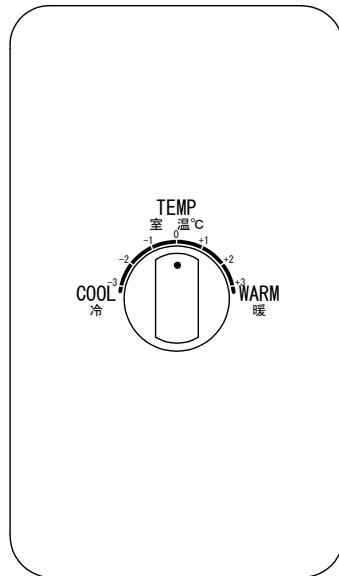

QY7290B3200

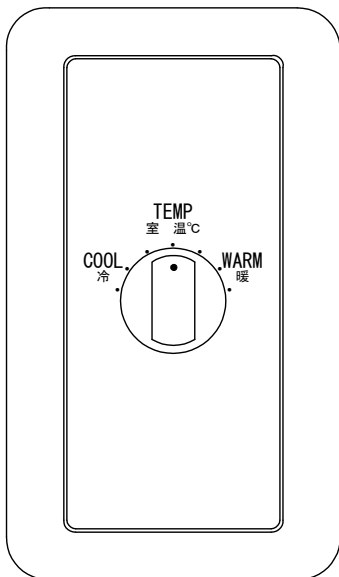

QY7290A3300

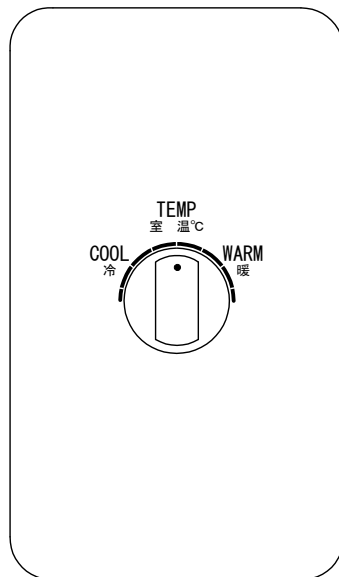

QY7290B3300

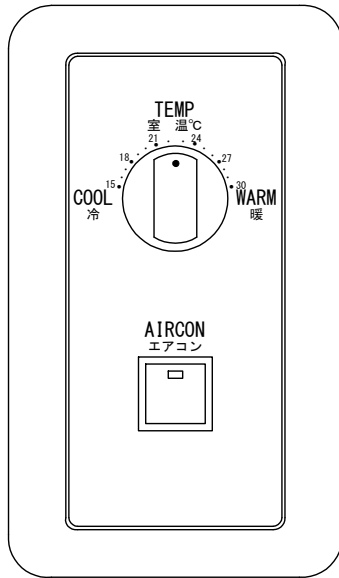

QY7290A3110

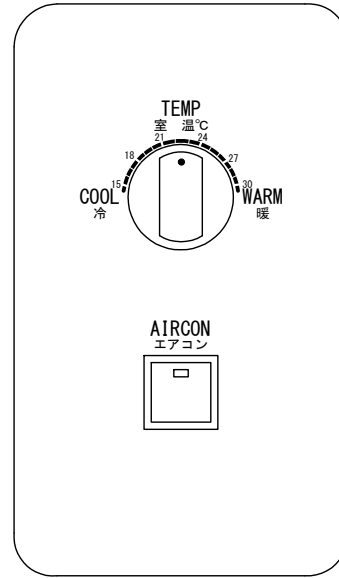

QY7290B3110

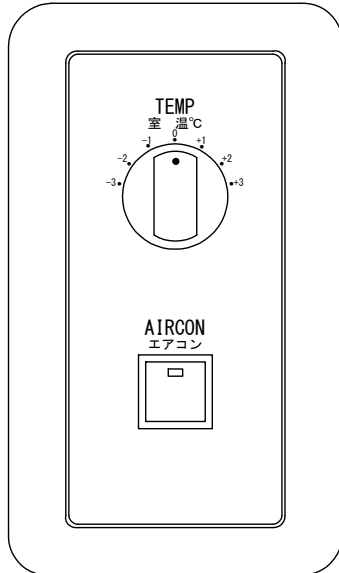

QY7290A3210

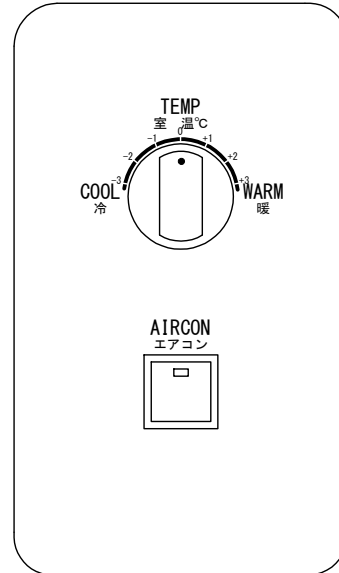

QY7290B3210

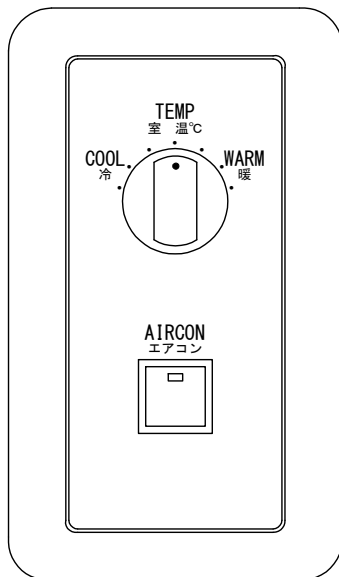

QY7290A3310

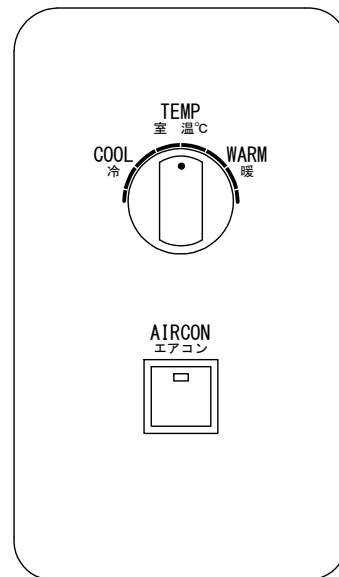

QY7290B3310

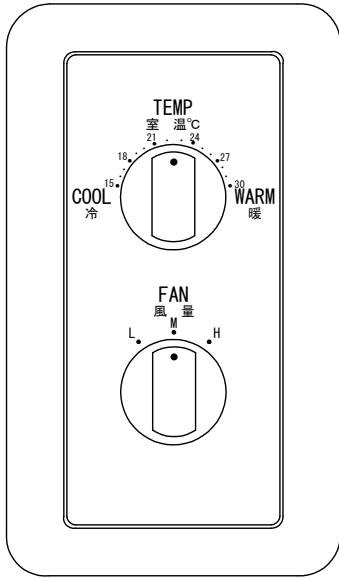

QY7290A3120

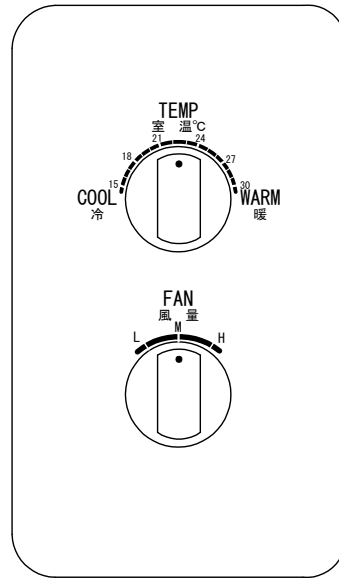

QY7290B33120

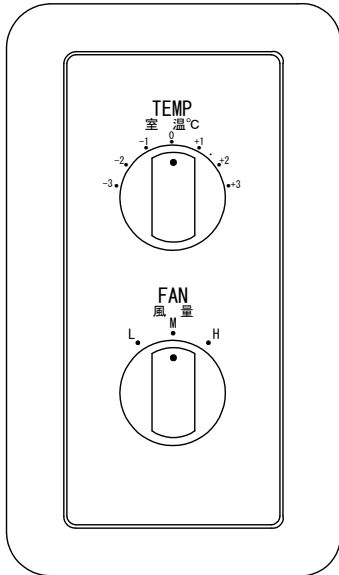

QY7290A3220

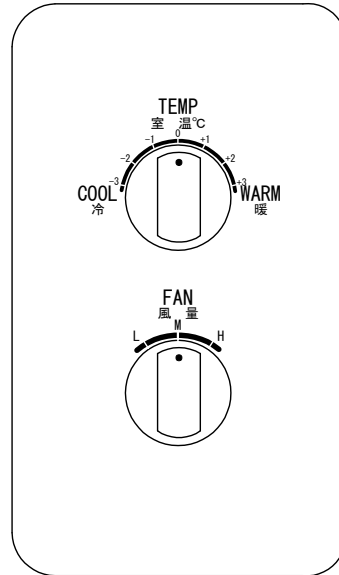

QY7290B3220

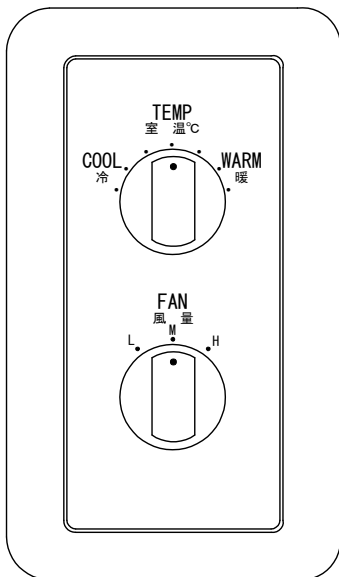

QY7290A3320

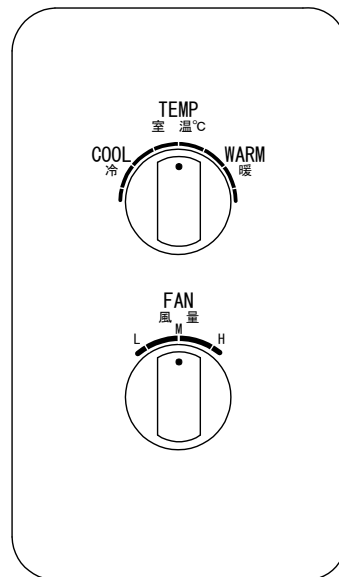

QY7290B3320

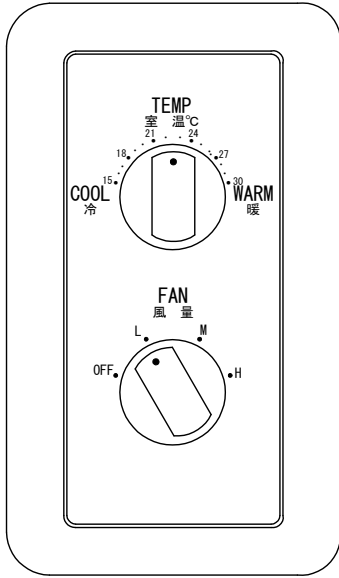

QY7290A3130

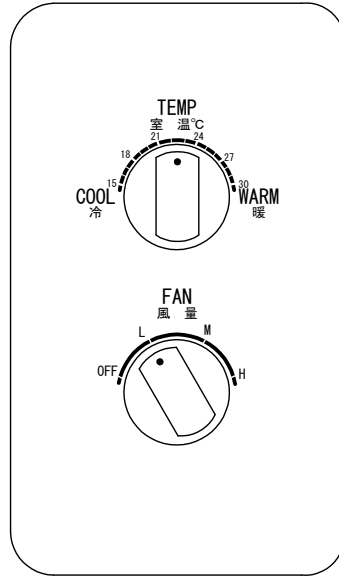

QY7290B3130

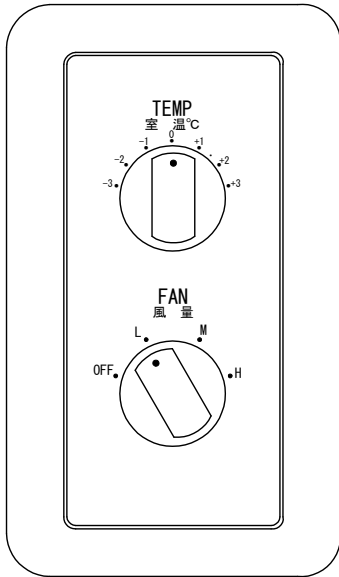

QY7290A3230

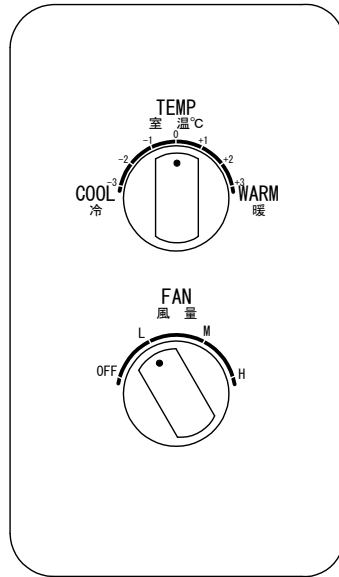

QY7290B3230

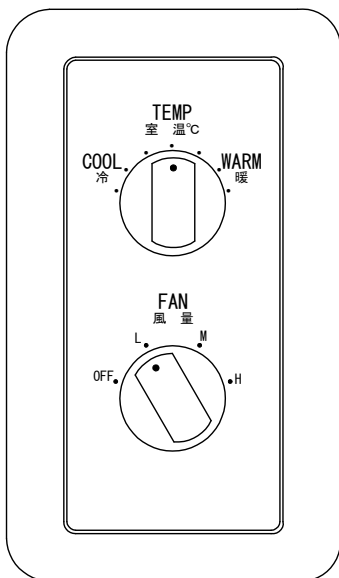

QY7290A3330

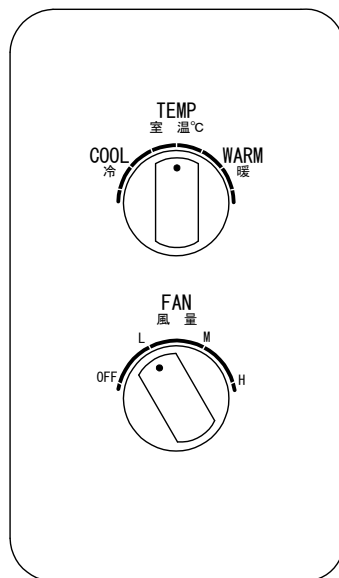

QY7290B3330

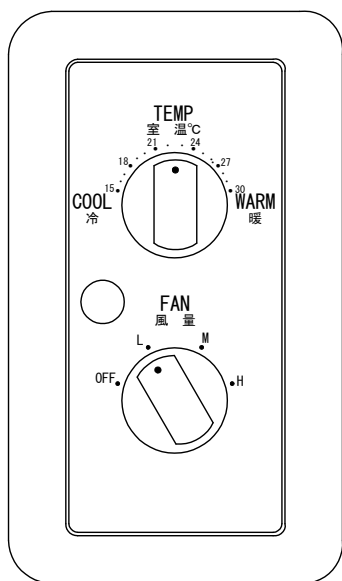

QY7290A4130

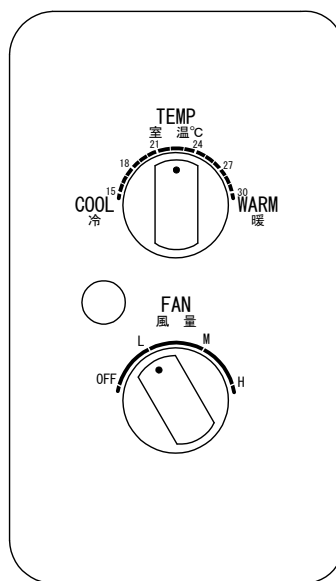

QY7290B4130

Dimensions (mm) (Refer to the previous page for the front view of the QY7290B.)

W/o fan speed switch model (QY7290A**0*, QY7290A**1*)

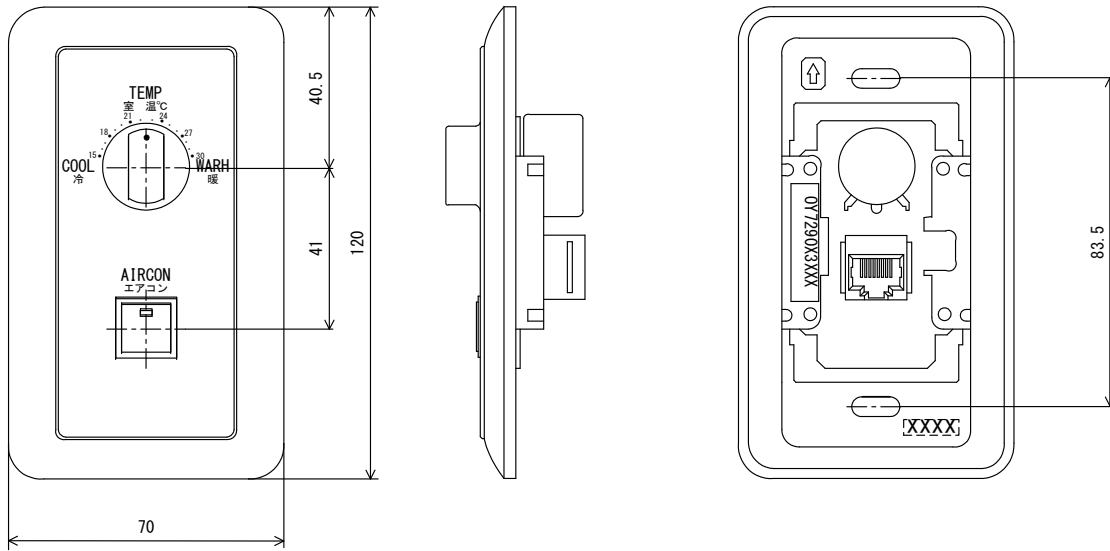

(QY7290B**0*, QY7290B**1*)



Fan speed switch model (QY7290A/4*2*, QY7290A/4*3*)

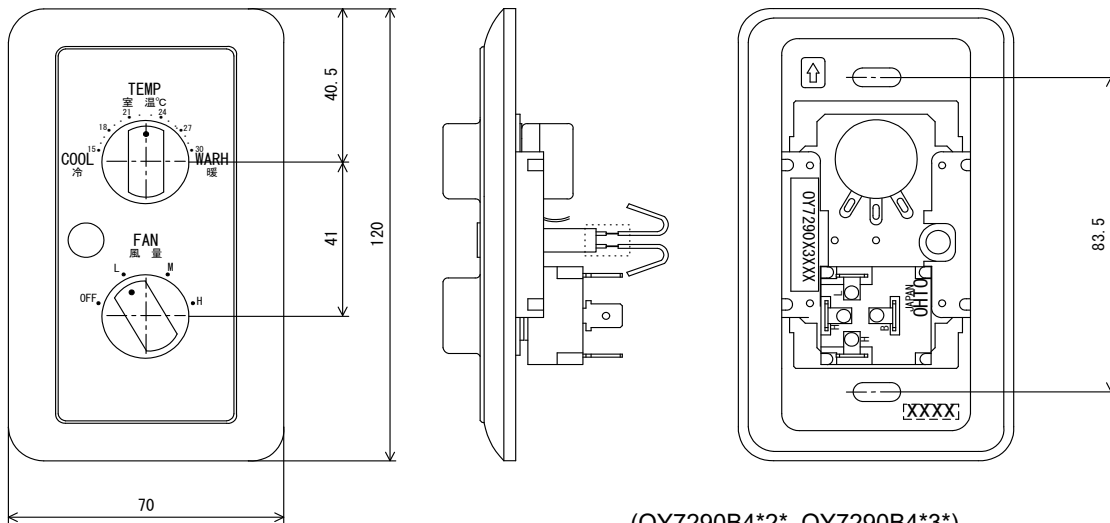

(QY7290B4*2*, QY7290B4*3*)

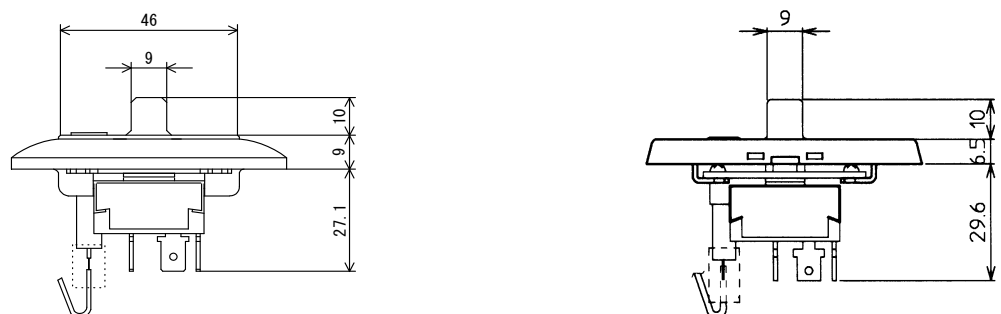

Installation

1) Flush mounting

Use one of the following parts. (Fan speed switch model must be flush mounted. Only No.②, below, is available.)

- ① Flush-mounted switch box for one thermo-plate (Select with or without cover.)
- ② Medium square outlet box (4-inch square junction box, mounting pitch: 83.5 mm)

2) Exposed mounting

(When fan speed switch is provided, do not mount Neoplate so that it is exposed.)

Use the following part when installing.

- Exposure type switch box for 1 thermo-plate.

3) Mounting on floating wall, partition

Cut panel and install referring to the diagram below. Purchase mounting screw (mounting pitch 83.5 mm) locally.

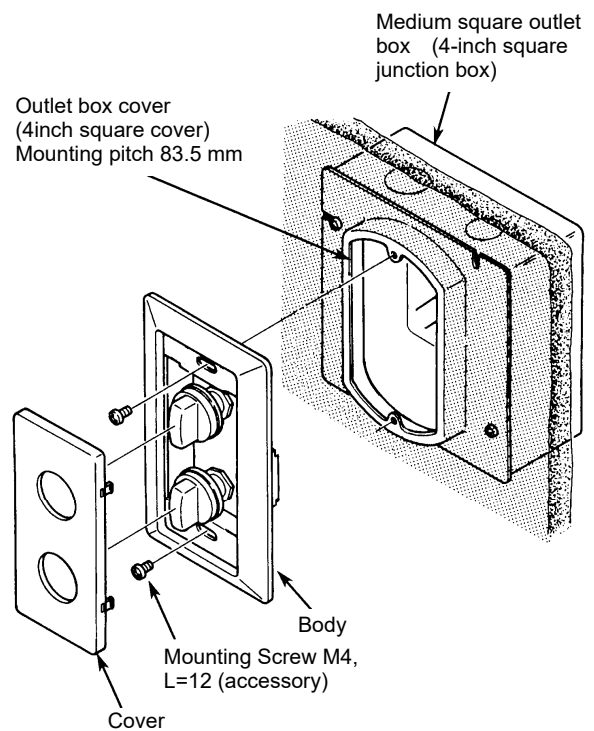
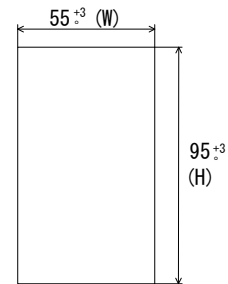

Mounting example

Wiring

1) W/o fan speed switch model (QY7290***0*, QY7290***1*)

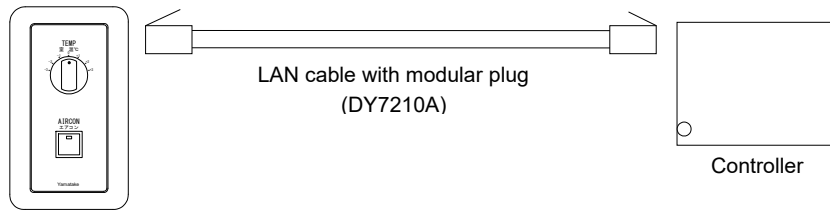

Connect to CN1 of IVC, IFC, Microstat control unit.

* Refer to the following diagram for relationship between number of modular connector and setpoint module, air-conditioning switch.

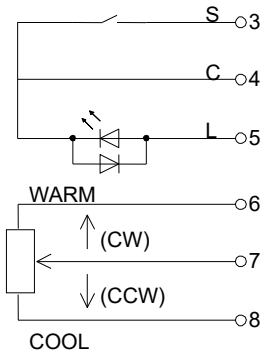

2) Fan speed switch model (QY7290***2*, QY7290***3*)

① Temperature setting switch model

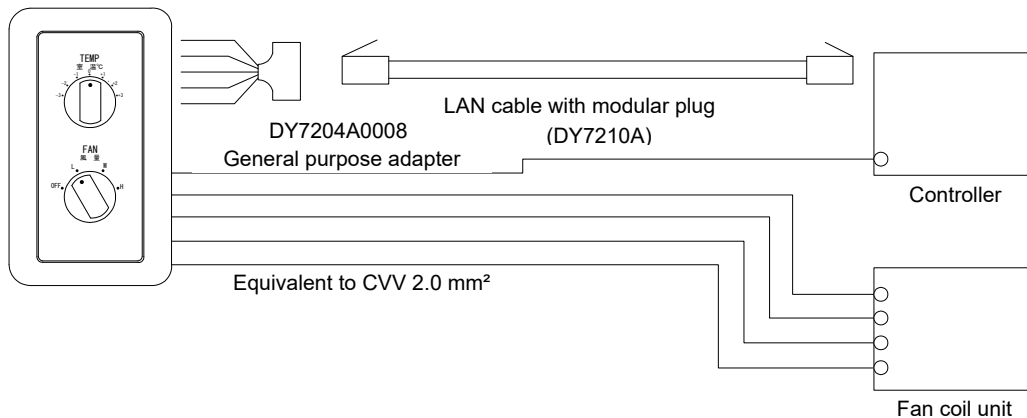

Note1: DY7204A0008 is the model number for a pack of ten pcs.

- For IFC and Microstat control unit, connect the modular cable to "CN1".

② Air-conditioning switch model (QY7290**02*)

The LAN cable with modular plug can be directly connected to the air-conditioning switch. The general purpose adapter in the above diagram is not required.

* Refer to the diagram below when connection to general purpose adapter.

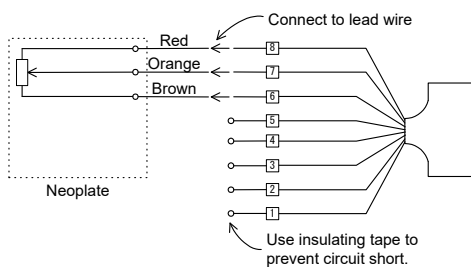

* Refer to the diagram below when connection to fan speed control switch.

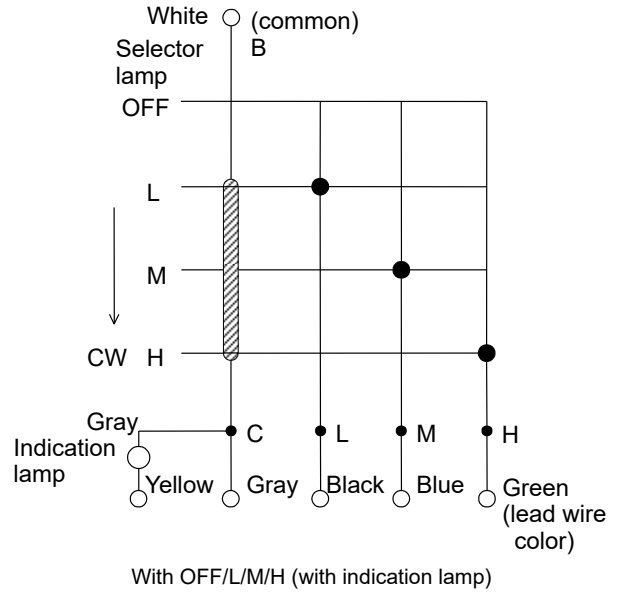
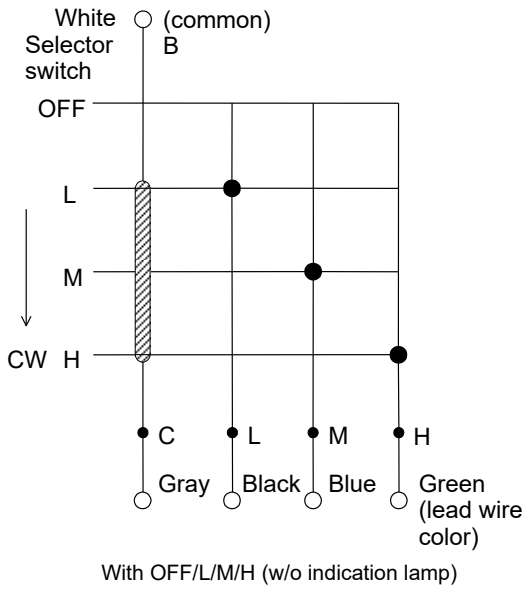
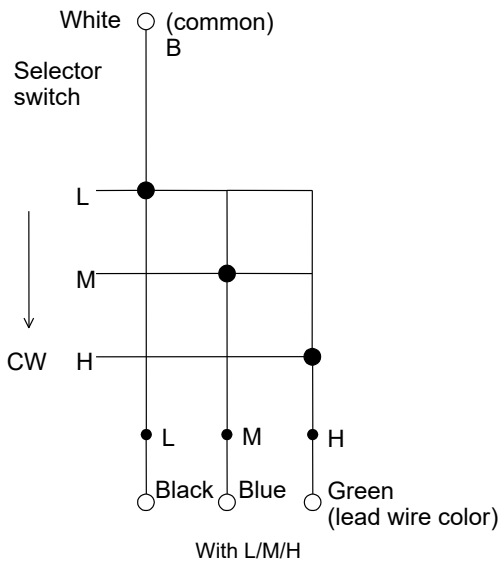

① With IFC (ON/ OFF type) + Air-conditioning switch

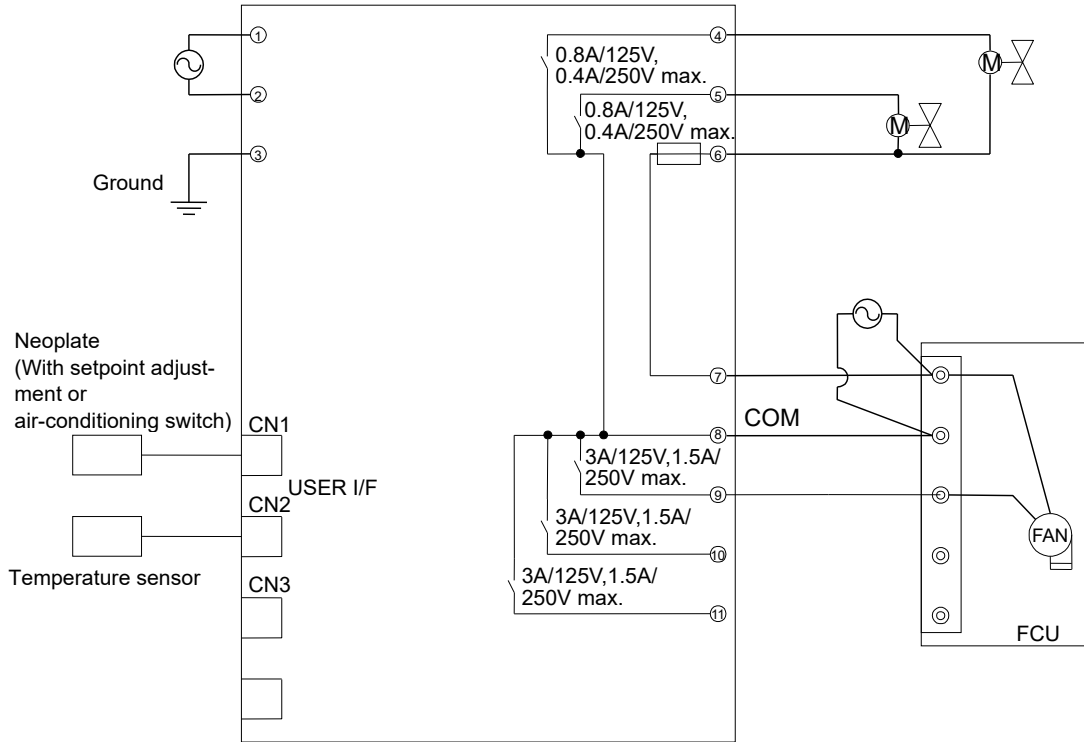

⚠ WARNING

- ⚠** • Disconnect power supply before beginning wiring. May result in electrical shock.
- ⚠** • Use crimp contacts with insulation jackets for wire terminals.
- ⚠** • Check for the loose wiring to prevent heat generation of equipment damage.

Note: Use fan output ON/OFF type for IFC.
Be sure to use a spring-return valve.

② With IFC (ON/OFF type) + Neoplate fan speed switch (L/M/H)

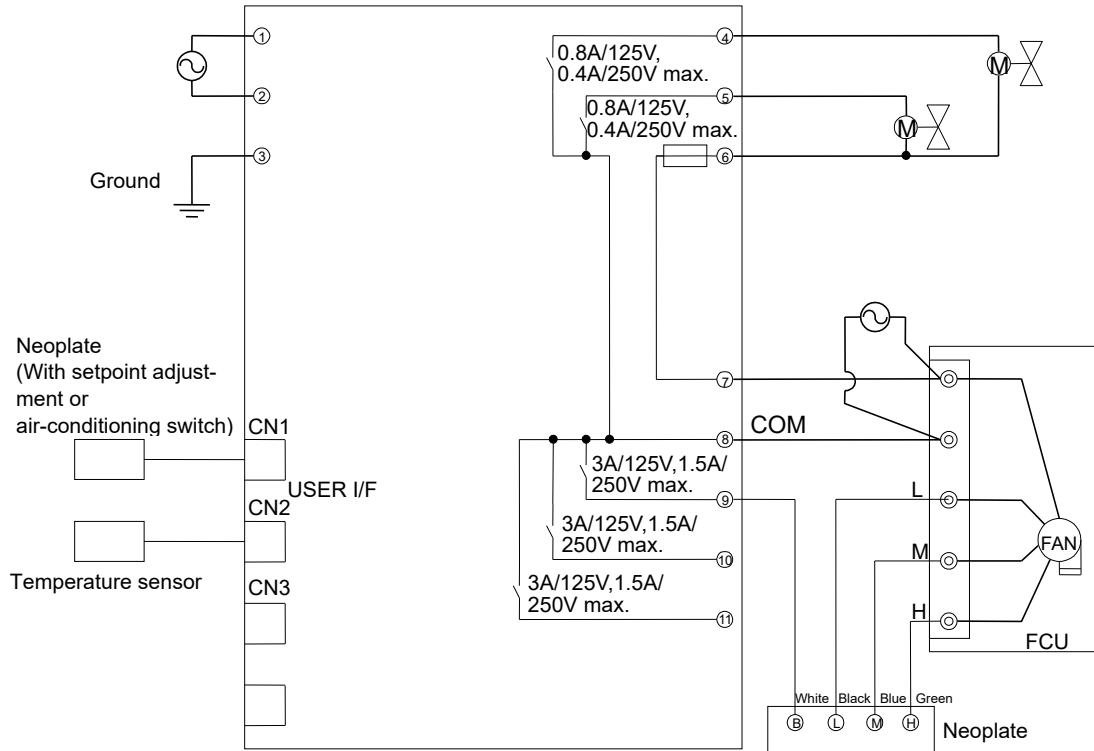

⚠ WARNING

- ⚠** • Disconnect power supply before beginning wiring. May result in electrical shock.
- ⚡** • Use crimp contacts with insulation jackets for wire terminals.
- ⚡** • Check for the loose wiring to prevent heat generation of equipment damage.

Note: Use fan output ON/OFF type for IFC.

③ With Microstat (ON/OFF type) + fan speed switch (L/M/H)

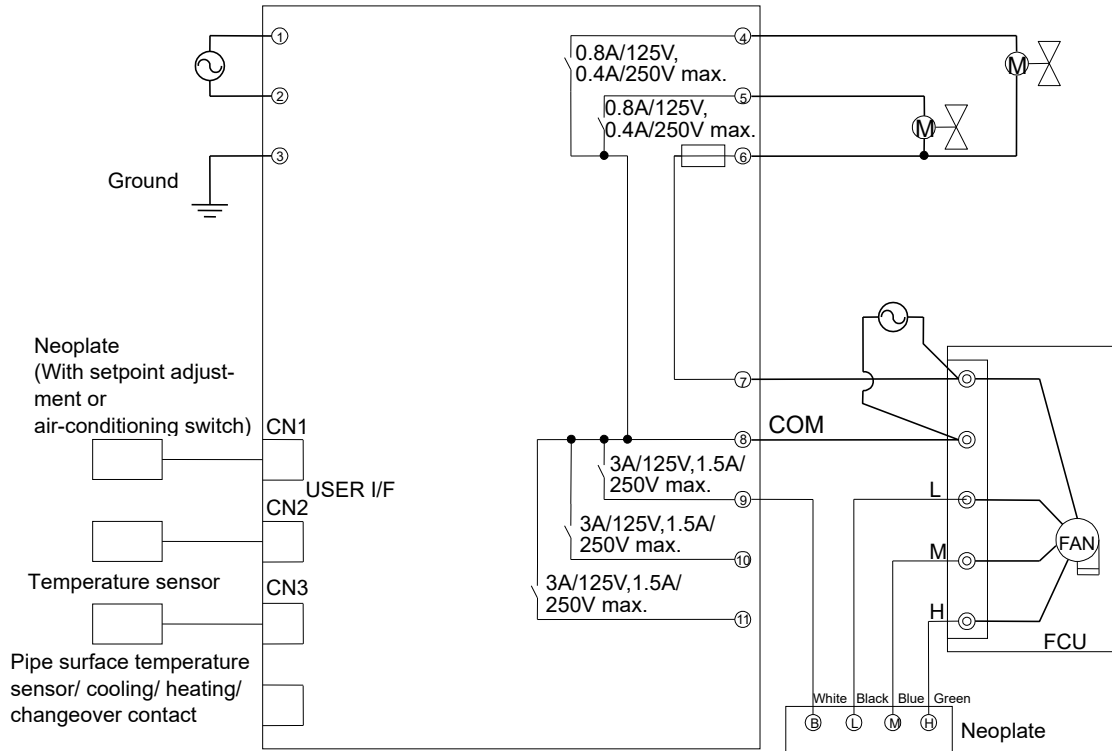

⚠ WARNING

- ⚠** • Disconnect power supply before beginning wiring. May result in electrical shock.
- ⚠** • Use crimp contacts with insulation jackets for wire terminals.
- ⚠** • Check for the loose wiring to prevent heat generation of equipment damage.

Note: Use fan output ON/OFF type for Microstat.
Be sure to use a spring-return valve.

④ With IFC (proportional control model) + air-conditioning switch

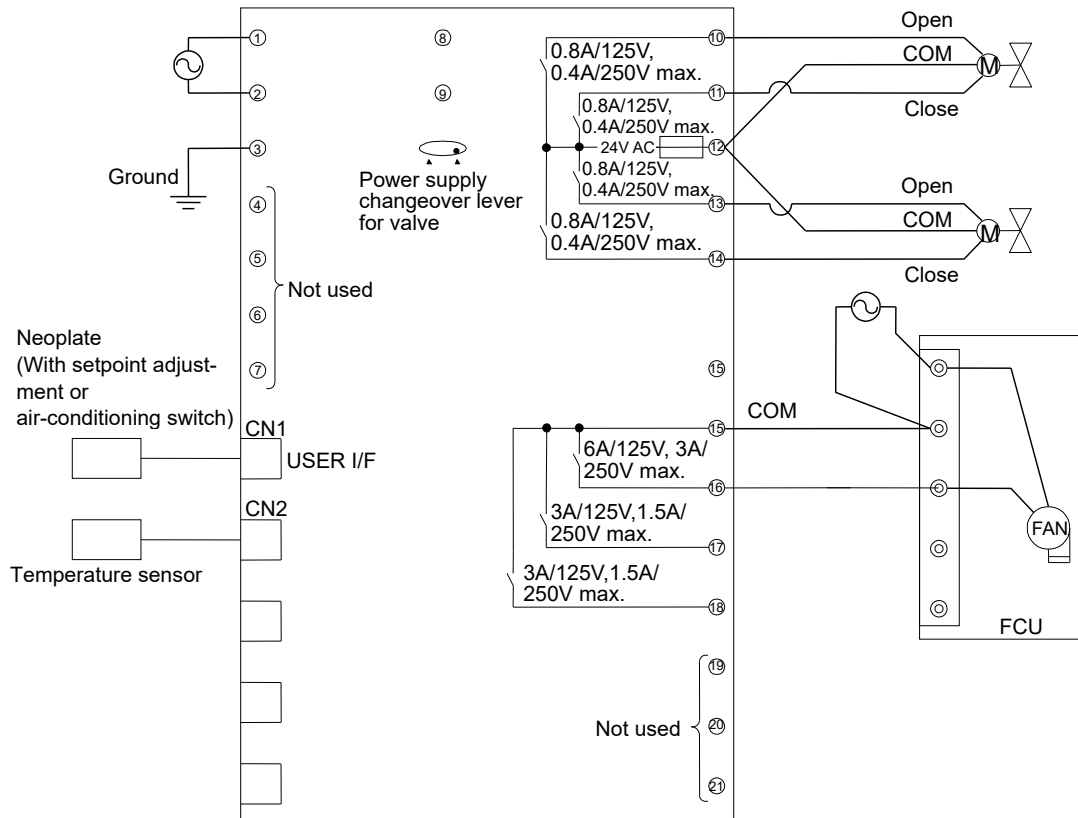

⚠ WARNING

- ⚠** • Turn off the power supply first if the wiring is installed or removed.
- ⚠** • Use crimp contacts with insulation jackets for wire terminals.
- ⚠** • Establish a proper ground. Improper ground may cause fire due to electrical shock or equipment damage.
- ⚠** • Check for the loose wiring to prevent heat generation of equipment damage.

Note: Use fan output ON/OFF type for IFC.

⑤ With IFC (proportional control model) + Neoplate fan speed switch (L/M/H)

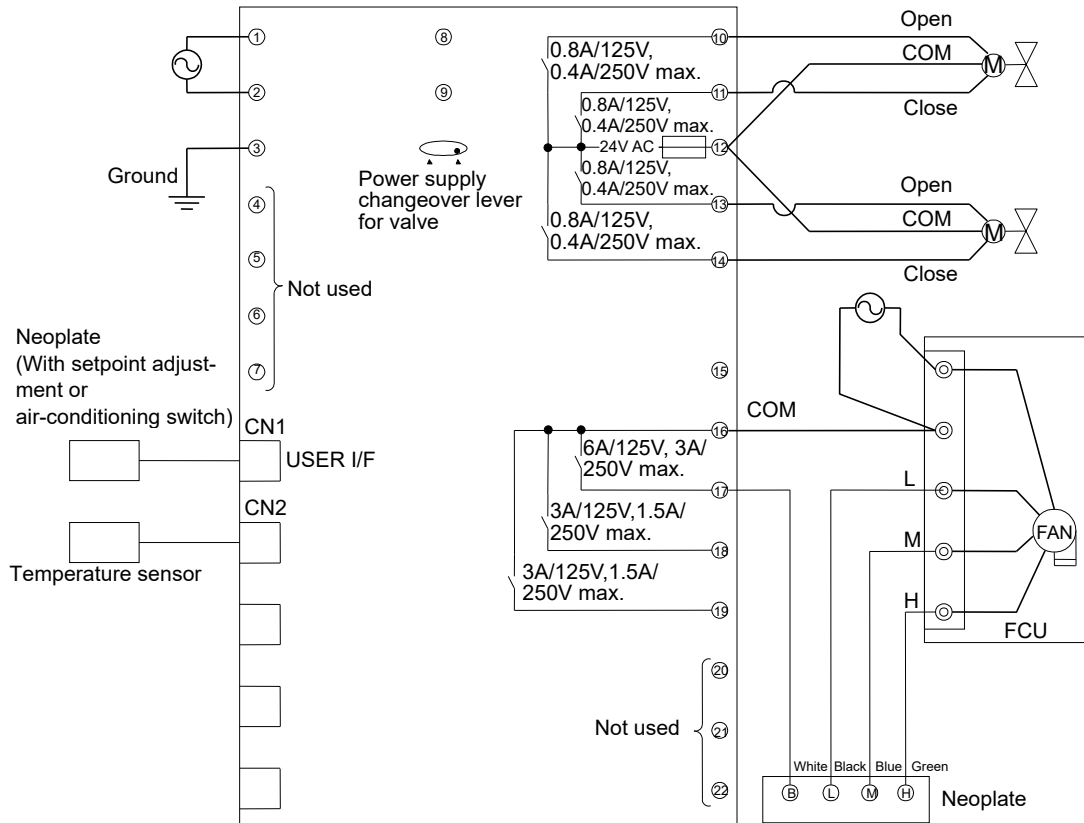

⚠ WARNING

- ⚠** • Disconnect power supply before beginning wiring. May result in electrical shock.
- ⚠** • Use crimp contacts with insulation jackets for wire terminals.
- ⚠** • Establish a proper ground. Improper ground may cause fire due to electrical shock or equipment damage.
- ⚠** • Check for the loose wiring to prevent heat generation or equipment damage.

Note: Use fan output ON/OFF type for IFC.

⑥ With Microstat (proportional control model) + fan speed switch (L/M/H)

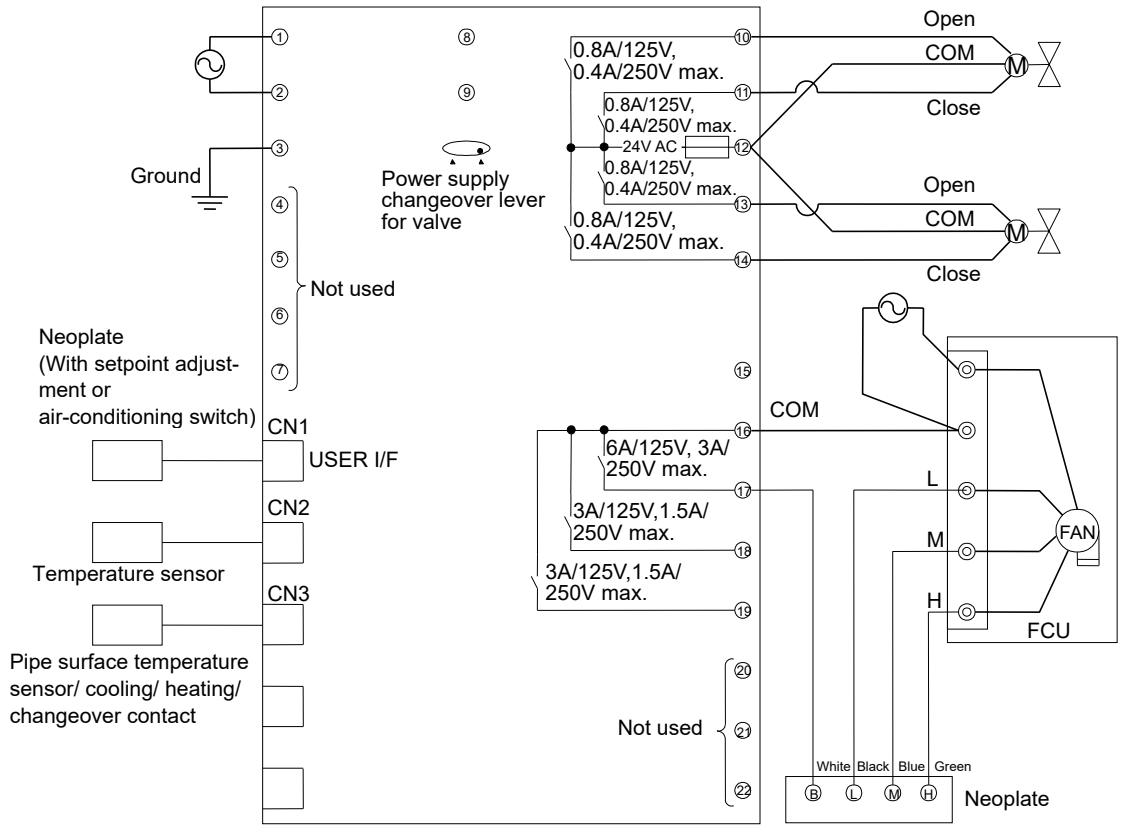

⚠ WARNING

- ⚠ • Turn off the power supply first if the wiring is installed or removed.
- ⚠ • Use crimp contacts with insulation jackets for wire terminals.
- ⚠ • Establish a proper ground. Improper ground may cause fire due to electrical shock or equipment damage.
- ⚠ • Check for the loose wiring to prevent heat generation of equipment damage.

Note: Use fan output ON/OFF type for Microstat.

⑦ With Microstat (ON/OFF control model) +Neoplate fan speed switch (OFF/L/M/H)

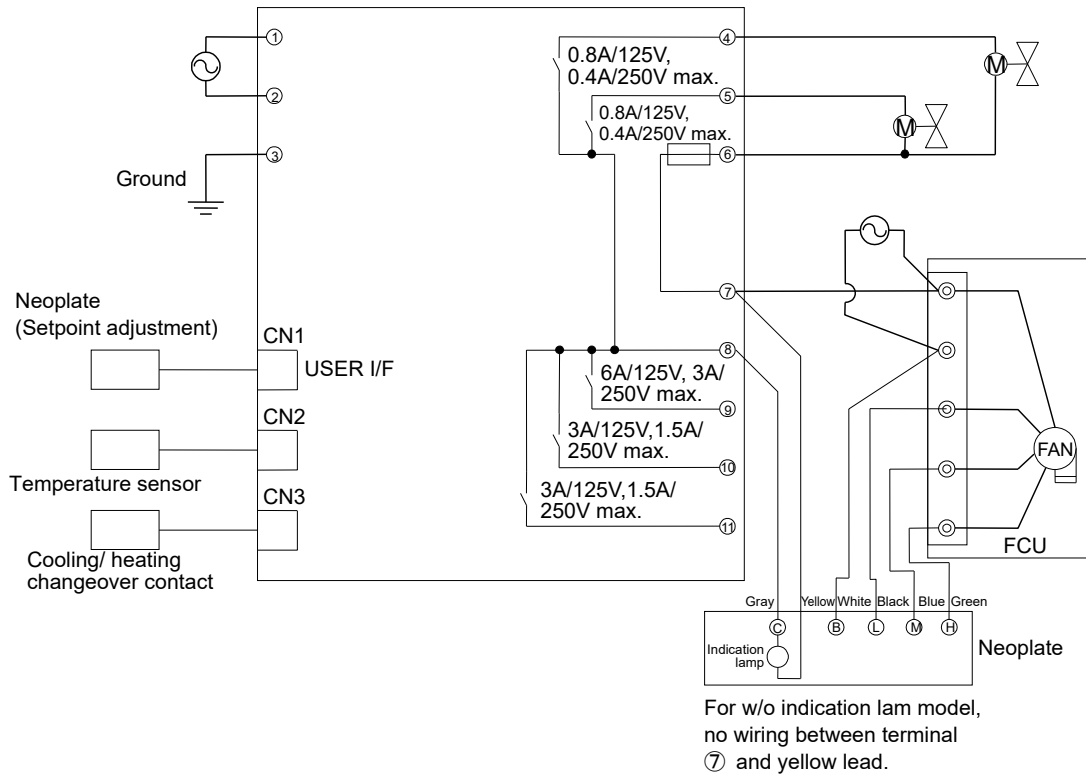

⚠ WARNING



- Disconnect power supply before beginning wiring. May result in electrical shock.



- Use crimp contacts with insulation jackets for wire terminals.



- Establish a proper ground. Improper ground may cause fire due to electrical shock or equipment damage.



- Check for the loose wiring to prevent heat generation or equipment damage.

Note: Be sure to use a spring return valve.

Even if the fan coil unit is set from off to L/M/N (operating status) using the Neoplate, the Microstat Controller does not recognize the change of status of the fan coil. The piping temperature sensor should not be used for chilled/hot water determination.

* If use of the piping temperature sensor is unavoidable for chilled/hot water determination, use the “power supply status monitoring” of valve proportional type of the Microstat controller. In this case you must change it to ON/OFF valve function. (For further information, refer to Parameter No. 1 in the WY7605 Engineering Manual.)

Connect Valve 1 between Terminals 10 and 12 of the controller and Valve 2 between Terminals 12 and 13. Supply external power to the valve. (Turn the power supply switchover lever of the controller to OUTSIDE.)

⑧ With Microstat (proportional control model) + fan speed switch (OFF/L/M/H)

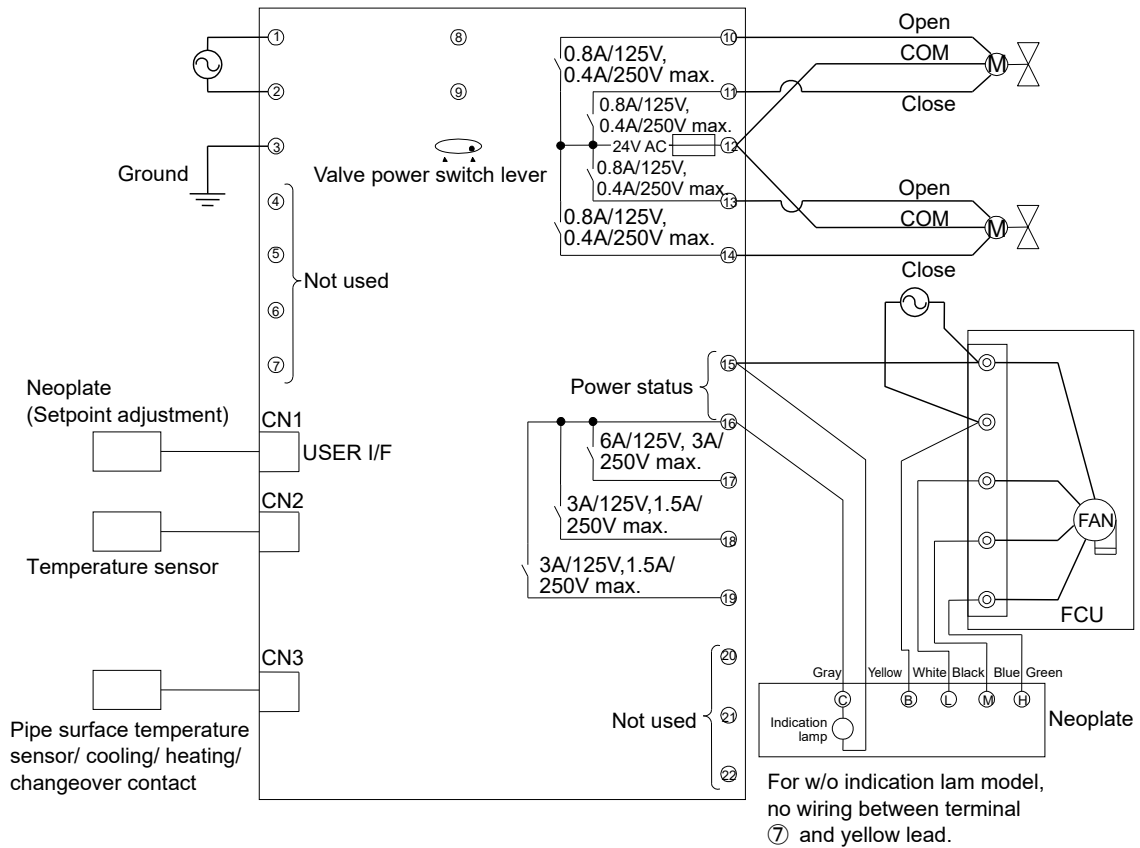

⚠ WARNING

- ⚠ • Disconnect power supply before beginning wiring. May result in electrical shock.
- ⚠ • Use crimp contacts with insulation jackets for wire terminals.
- ⚠ • Establish a proper ground. Improper ground may cause fire due to electrical shock or equipment damage.
- ⚠ • Check for the loose wiring to prevent heat generation or equipment damage.

Note: Do not forget to the power status of fan coil unit into the terminal 15 and 16 of Microstat. Set "power status provided" (serviceman parameter No.5=1) by Microstat. Otherwise, no valve interlock is made.

Maintenance

Requires no special maintenance.

If replacement is required, replace all functional parts not just one part.

Cautions on use

- 1) Do not use model with fan speed switch (OFF/L/M/H type: QY7290***3*) with IFC.
This combination will cause such errors as inability to control from building automation system or compact management panel, or inability when operating from Neopanel.
- 2) Do not use the air-conditioning switch only type (QY7290***0*) of the Neoplate for the Microstat. The Microstat does not recognize the air-conditioning switch only type, so the switch will not operate.
(Temperature setting and air-conditioning type can be used.)
- 3) If voltage of rating or above is accidentally applied, safety requires replacement of the product.
- 4) For the adjustment of the controller to be combined, refer to the relevant adjustment manuals.

This blank page was added for page layout purposes.

azbil

Specifications are subject to change without notice.

Azbil Corporation
Building Systems Company

<https://www.azbil.com/>