

Inflex™ VC

Variable Air Volume Controller with Actuator for SC-bus Communication

Overview

Inflex VC (Inflex: named for “Infinity” and “Flexible”) Model WY5206C is a VAV controller with an actuator that communicates via our proprietary protocol, SC-bus. Inflex VC provides high-performance DDC of VAV unit in a building air-conditioning system. Thus, Inflex VC, networked even within a complicated HVAC system, controls VAV unit.

Besides, Inflex VC offers building owners and operators the flexible and enhanced controls of temperature and VAV for various VAV units.

Inflex VC sends unique energy-saving information to its networked SC-bus zone controller, enhancing overall controllability of a building management system.

DDC: Direct digital control

HVAC: Heating, ventilation, and air conditioning

VAV: Variable air volume

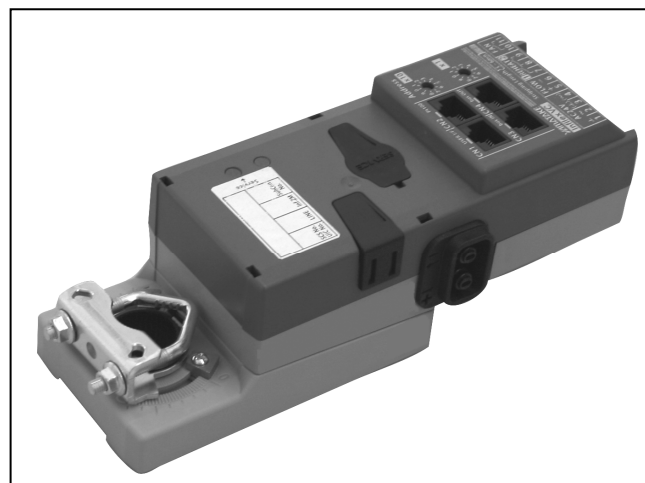

Features

- Economical efficiency:
 - Temperature and air-volume are controlled by a single controller.
 - VAV controller that resides on an actuator offers great value.
- Wide range of application:
 - Most of the major VAV types for industry are preconfigured in the controller.
- Unique energy conservation control:
 - VAV damper opens wide to minimize the fan power consumed by static pressure.
 - Network with a zone controller allows supply air temperature to be modified at an optimum level.
- Advanced building management integrated into BMS:
 - Our digital user terminal Neopanel enables users and operators to modify the preset setting of temperature and operating schedule (to extend) and offers flexibility of temperature control and schedule control.
- CE Marking certified product:
 - Inflex VC Model WY5206C conforms to all the applicable standards of CE Marking.

* Our controller Inflex series: Inflex is named for “Infinity” and “Flexible”.

Safety Precautions

Please read instructions carefully and use the product as specified in this manual. Be sure to keep this manual nearby for quick reference.

Restrictions on Use

This product was developed, designed, and manufactured for general air conditioning use.

Do not use the product in a situation where human life may be at risk or for nuclear applications in radiation controlled areas. If you wish to use the product in a radiation controlled area, please contact Azbil Corporation.



Particularly when the product is used in the following applications where safety is required, implementation of fail-safe design, redundant design, regular maintenance, etc., should be considered in order to use the product safely and reliably.

- Safety devices for protecting the human body
- Start/stop control devices for transportation machines
- Aeronautical/aerospace machines







For system design, application design, instructions for use, or product applications, please contact Azbil Corporation.





Azbil Corporation bears no responsibility for any result, or lack of result, deriving from the customer's use of the product.





Warnings and Cautions

	WARNING	Alerts users that improper handling may cause death or serious injury.
	CAUTION	Alerts users that improper handling may cause minor injury or material loss.

Signs









	Alerts users possible hazardous conditions caused by erroneous operation or erroneous use. The symbol inside  indicates the specific type of danger. (For example, the sign on the left warns of the risk of electric shock.)
	Notifies users that specific actions are prohibited to prevent possible danger. The symbol inside  graphically indicates the prohibited action. (For example, the sign on the left notifies that disassembly is prohibited.)
	Instructs users to carry out a specific obligatory action to prevent possible danger. The symbol inside  graphically indicates the actual action to be carried out. (For example, the sign on the left indicates general instructions.)

 WARNING	
	Before wiring and maintenance, be sure to turn off the power to the product. Failure to do so might cause electric shock.
	To control a VAV unit with electric heater, be sure to provide a circuit to prevent temperature rise. Failure to do so might cause fire or overheating.
	To control a VAV unit with electric heater, configure the system so that air conditioning unit will not stop when the VAV unit is turned off. This allows the electric heater to cool down after it is turned off. Failure to do so might cause fire or device damage.

 CAUTION (1/2)	
	Installation and wiring must be performed by qualified personnel in accordance with all applicable safety standards.
	Install and use the product in a location that meets the operating conditions (temperature, humidity, power, vibration, shock, mounting direction, atmospheric condition, etc.) as listed in the specifications. Failure to do so might cause fire or device failure.
	All wiring must comply with applicable codes and ordinances.

 CAUTION

(2/2)

	Make sure all the wires are tightly connected to the corresponding terminals. Failure to do so might cause device failure or overheating.
	For wiring, strip each wire insulation as specified in this manual. If the strip length is longer than the specified, the stripped part of the wires will be exposed, causing electric shock or short circuit between adjacent terminals. If it is shorter, the stripped part will not contact the connector.
	If more than the rated power voltage is applied to the product, replace the product with new one for your safety. Failure to do so might cause device failure or overheating.
	Be sure to provide a circuit breaker for the power to the product as the product does not have a power switch.
	Do not test the withstand voltage of the product. Doing so might cause accident or device failure.
	Do not disassemble the product. Doing so might cause electric shock or device failure.
	Do not touch the moving parts of the product. Doing so might cause injury.
	Do not incinerate the product for waste disposal. The cover will generate toxic gas when being incinerated. Do not reuse all or part of this product after disposal of the product.
	Dispose of the product as industrial waste in accordance with your local regulations. Do not reuse all or part of this product.

System Configuration

Infilex VC integrated into our building management system (BMS): *savic-net™ FX*

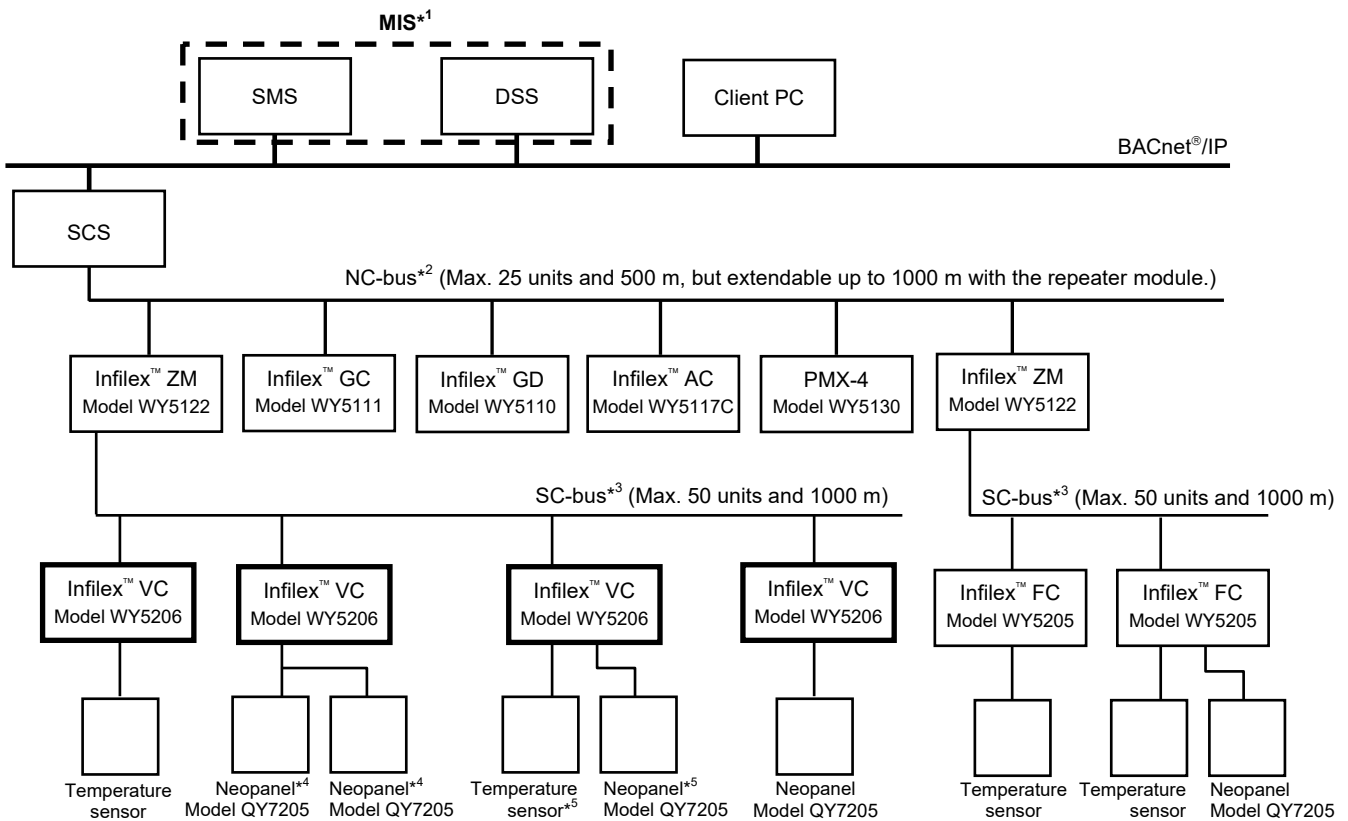

DSS: Data Storage Server
 MIS: Management Integration Server
 PMX-4: PARAMATRIX™ 4
 SCS: System Core Server
 SMS: System Management Server

Notes:

- *1 MIS may be used instead of SMS and DSS for your *savic-net FX* system. Note that MIS cannot coexist with SMS or DSS in the same system.
- *2 Maximum number of remote units (also known as "controllers") that can be connected to SCS via NC-bus varies depending on the system configurations.
- *3 Maximum of 50 sub remote units (also known as "sub controllers") such as Infilex VC and Infilex FC can be connected to Infilex ZM via SC-bus.
- *4 Up to two Neopanel can be connected to one Infilex VC.
 For two Neopanel connection, provide Model QY7205CXXX1 for the address 1 and Model QY7205CXXX2 for the address 2 and connect to Infilex VC via modular branch unit (Part No. DY7203A0000).
- *5 Neopanel and a temperature sensor can be connected to the same Infilex VC.

Figure 1. System configuration example: Infilex VC integrated into *savic-net FX* BMS

Model Numbers

Base model number	Power	—	Actuator	Airflow sensor DO output	—	Description			
WY5206	C	5				Inflex VC for SC-bus communication			
						24 V AC			
	(Note 1)						Fixed.		
							1	5 N·m torque	
		(Note 2)						10 N·m torque	
								2	
		(Note 3)						Airflow pulse input, DO: 0 pt.	
								0	
								1	With internal airflow sensor, DO: 0 pt.
								2	Airflow pulse input DO: 3 pts. (2 pts. for reheat control, 1 pt. for fan control)
(Note 3)						With internal airflow sensor, DO: 3 pts. (2 pts. for reheat control, 1 pt. for fan control)			
						3			
						0	Fixed.		

Note 1: Only model WY5206C5210 is available.

Note 2: Only model WY5206C5100 is available.

Note 3: Only model WY5206C5120 is available.

Part Numbers of Optional Parts and Tools

Item	Part number
Universal bracket	12595-00001
Modular branch unit	DY7203A0000
Modular relay units (5 pieces/set)	DY7202A0000
Adapters for connecting to a Pt100 temperature sensor (10 pieces/set)	DY7204A0003
Adapters for connecting to a user terminal (10 pieces/set)	DY7204A0008
Modular plugs (100 pieces/set)	DY7207A0100
Modular crimper	DY7205A0002
Modular cable tester	DY7206A0000

Note:

* For details of the optional parts and tools shown above, see the **Optional Parts** and **Optional Tools** sections.

Specifications

Basic specifications

Item	Specification		
Power supply	24 V AC ± 15 % (50 Hz/60 Hz)		
Power consumption	5 N·m: 9 VA / 10 N·m: 10 VA		
Rated torque	5 N·m / 10 N·m		
Operating range	To 95°		
Operating time (for 95° operating angle)	Operation mode	5 N·m torque type	10 N·m torque type
	Forced open/close	150 seconds	150 seconds
	Synchronisation (An operation mode to synchronise the actuator position with the damper position.)	75 seconds	86 seconds
	Automatic control (with variable speed)	120 to 300 seconds	120 to 300 seconds
Attachable damper shaft	5 N·m torque type		10 N·m torque type
	Thickness	Φ6 mm to Φ20 mm (circular cross section)	Φ8 mm to Φ26.7 mm (circular cross section)
		4.5 mm square to 14 mm square (square cross section)	5.7 mm square to 18.8 mm square (square cross section)
Length	37 mm or longer	40 mm or longer	
Operating environmental conditions	Temperature	0 °C to 50 °C	
	Humidity	10 %RH to 90 %RH (Non-condensing)	
	Vibration	Max. 3.2 m/s ² (10 Hz to 150 Hz)	
Transport/storage conditions	Temperature	-20 °C to 60 °C	
	Humidity	5 %RH to 95 %RH (Non-condensing)	
	Vibration	Max. 9.8 m/s ² (10 Hz to 150 Hz)	
Enclosure rating	Equivalent to IEC IP30: Dust-proof (in wired, covered, and plugged state)		
Sound power level	35 dB or lower		
Installation	In VAV control box		
Address setting	Rotary switch × 2		
Materials	Back plate: Zinc plated steel Clamps and screws : Zinc plated steel Housing: PC-ABS Cover of air flow sensor: Thermoplastic elastomer Cover of nonuse connector (for setting): Thermoplastic elastomer Universal bracket: Zinc plated steel		
Weight	5 N·m torque type: 500 g 10 N·m torque type: 800 g		

IEC: International Electrotechnical Commission

PC-ABS: Polycarbonate acrylonitrile butadiene styrene

VAV: Variable air volume

Input/output specifications

Unit to be connected	Input/output description	Input/output specification	Connection type	Wire/tube specification	
VAV unit	Air flow signal input	Air flow pulse	Voltage pulse input Voltage: 5 V DC \pm 20 % for high level 0 V DC to 0.5 V DC for low level Current: Max. 10 mA Pulse width: 450 μ s or more for high level 450 μ s or more for low level Frequency: Max. 1000 Hz + 10 % or less 100 Hz or higher for full span Current restriction resistance: 470 Ω	Terminal connection: Push-in terminal block	2.0 mm ² to 2.5 mm ² Max. 5 m
		Direct air flow sensor	Differential pressure input sensor Differential pressure sensing range: Δ P = 0 Pa to 250 Pa Temperature characteristics: \pm 0.5 % of full span $^{\circ}$ C (0 $^{\circ}$ C to 50 $^{\circ}$ C, 1013 hPa)	Tube connection	Length: Max. 1m at each port Inner diameter (flexible tube): 5.0 mm to 6.0 mm Inner diameter (inflexible tube): 5.5 mm to 6.5 mm Outer diameter: Max. 10.0 mm Material: PVC, silicon rubber (e.g., TYGON [®] Model R-3603)
	Heater and fan	Dry contact 30 V AC, 0.8 A or 30 V DC, 0.5 A	Terminal connection: Push-in terminal block	2.0 mm ² to 2.5 mm ² Max. 5 m	
Temperature sensor	Pt100 input	Pt100 temperature sensor Input temperature range: 0 $^{\circ}$ C to 50 $^{\circ}$ C	Connector connection* ¹	LAN cable* ² Max. 50 m	
User terminal	Temperature setting Air conditioning ON/OFF	Serial voltage transmission Transmission speed: 100 bps	Connector connection* ¹	LAN cable* ² Max. 50 m	
Communication line	SC-bus	Serial voltage transmission Transmission speed: 4800 bps	Connector connection* ¹	LAN cable* ² Max. 1000 m	
Power supply	—	Power supply voltage: 24 V AC \pm 15 %	Terminal connection: Push-in terminal block	2.0 mm ² to 2.5 mm ²	

Notes:

*1 For connector connection, use Bel Stewart Connector's Plug: Model SS-37000-002.

This plug is also available at Azbil Corporation. (Part No. DY7207A0100, 100 pieces/set)

*2 LAN cable compliant with EIA/TIA-568 Category 3 or over (Φ 0.5 mm \times 4 poles) is required.

For *1 and *2, the connector cable (regular cable: Part No. DY7210, short cable: Part No. DY7220) are available at Azbil Corporation.

Dimensions

5 N·m torque type

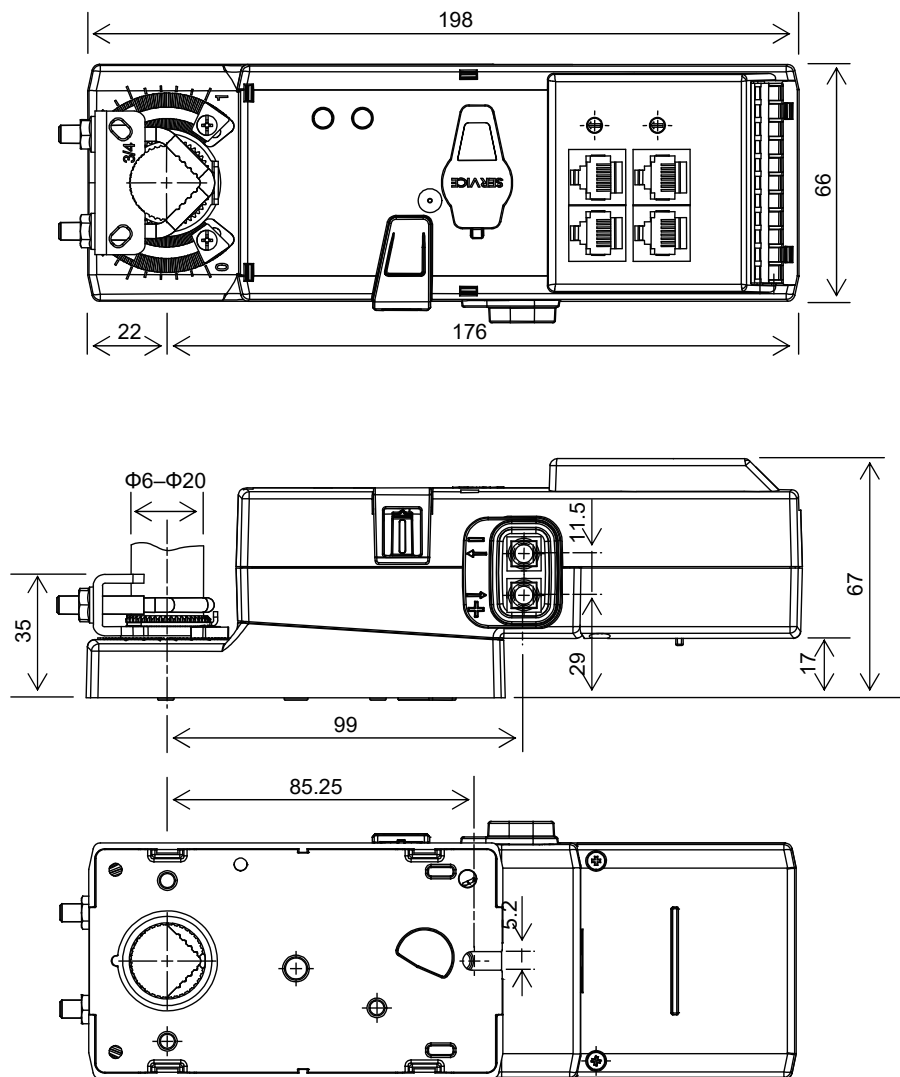

Figure 2. Dimensions: 5 N·m torque type (mm)

10 N-m torque type

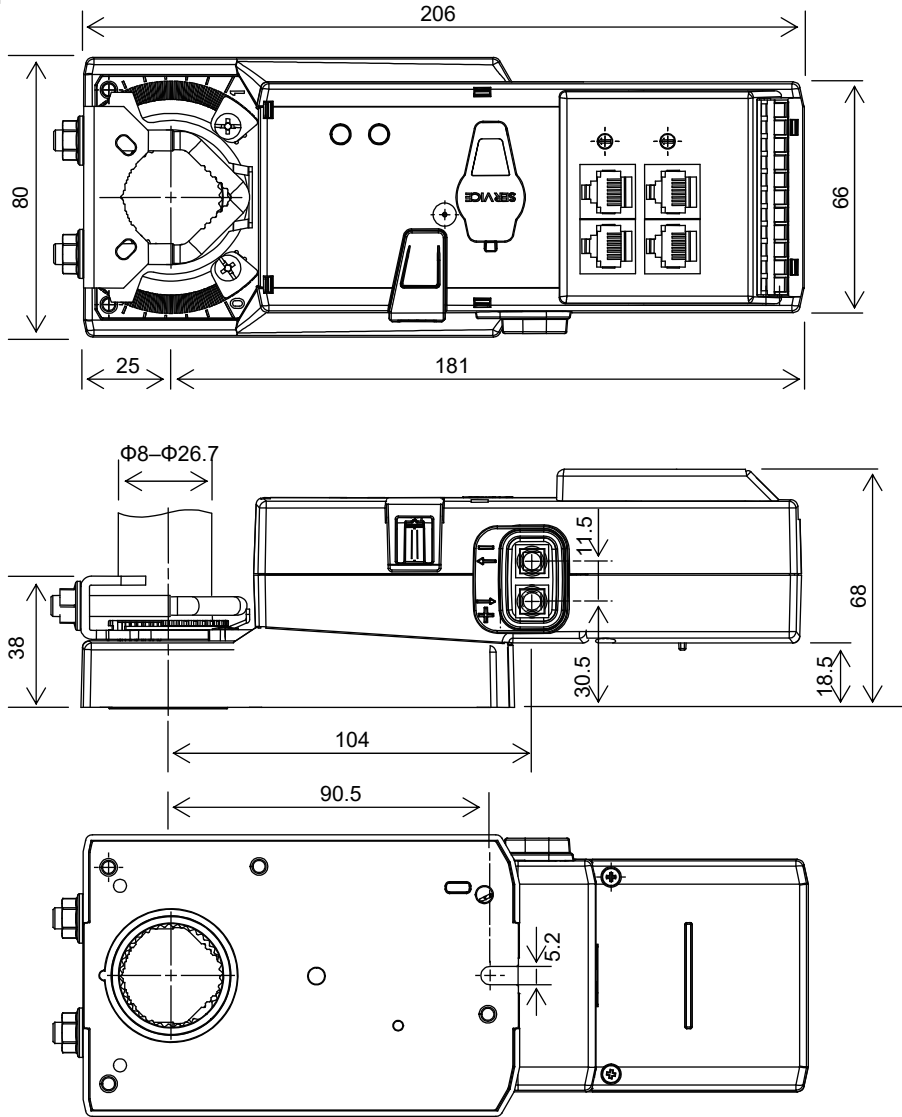

Figure 3. Dimensions: 10 N-m torque type (mm)

Universal bracket (requiring separate order)

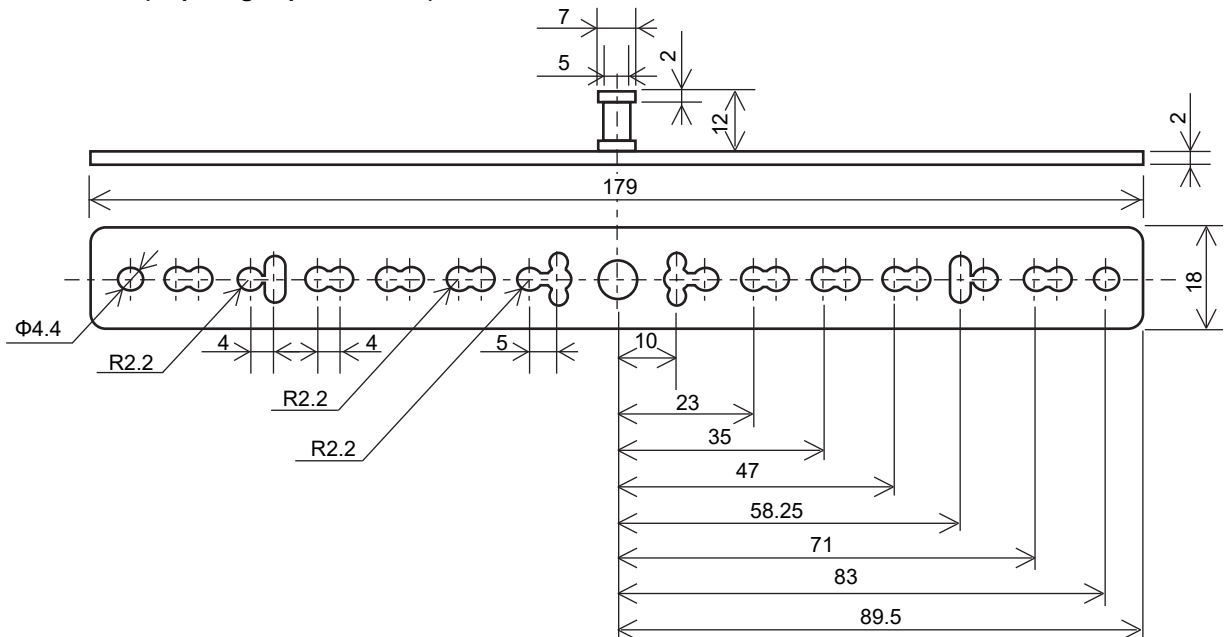

Figure 4. Dimensions: Universal bracket (mm)

Parts Identification

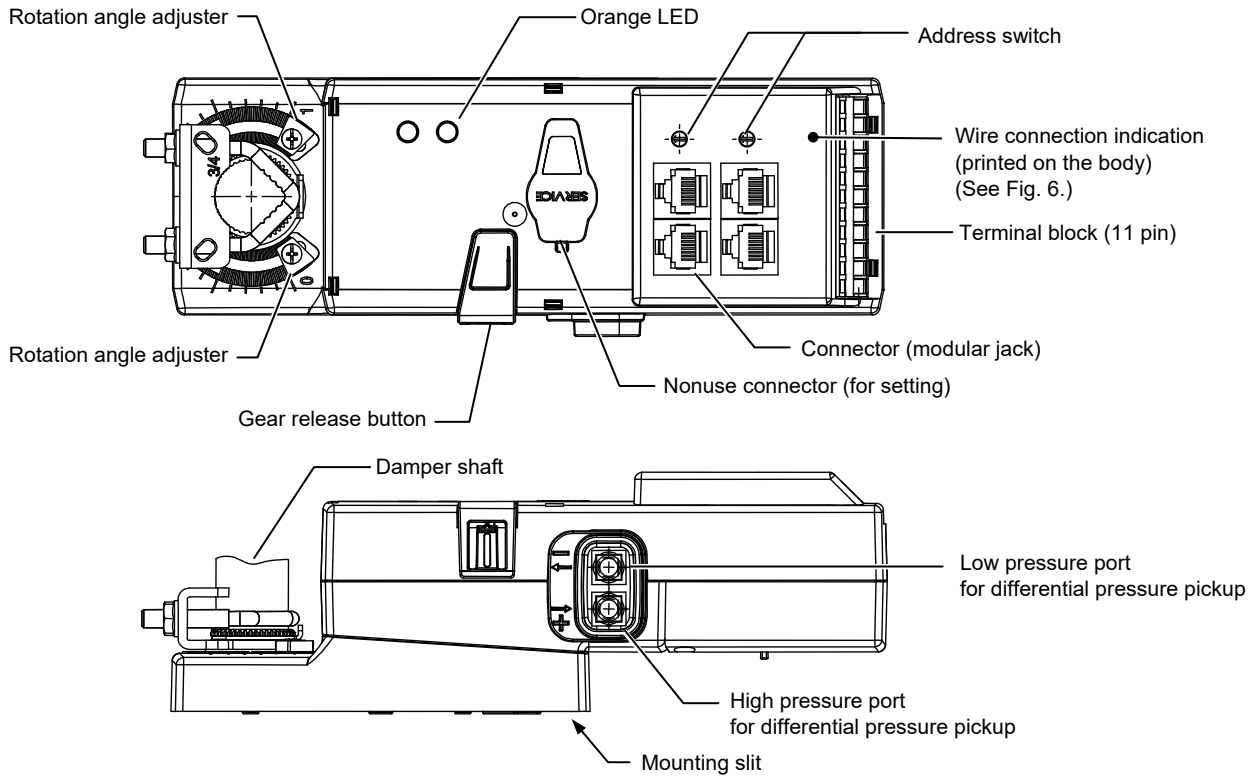

Figure 5. Parts identification

Wire Connection Indication

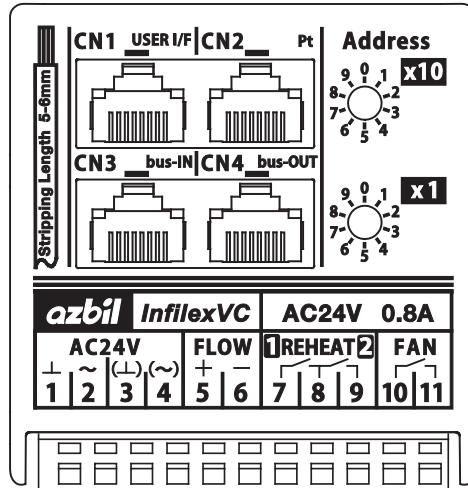
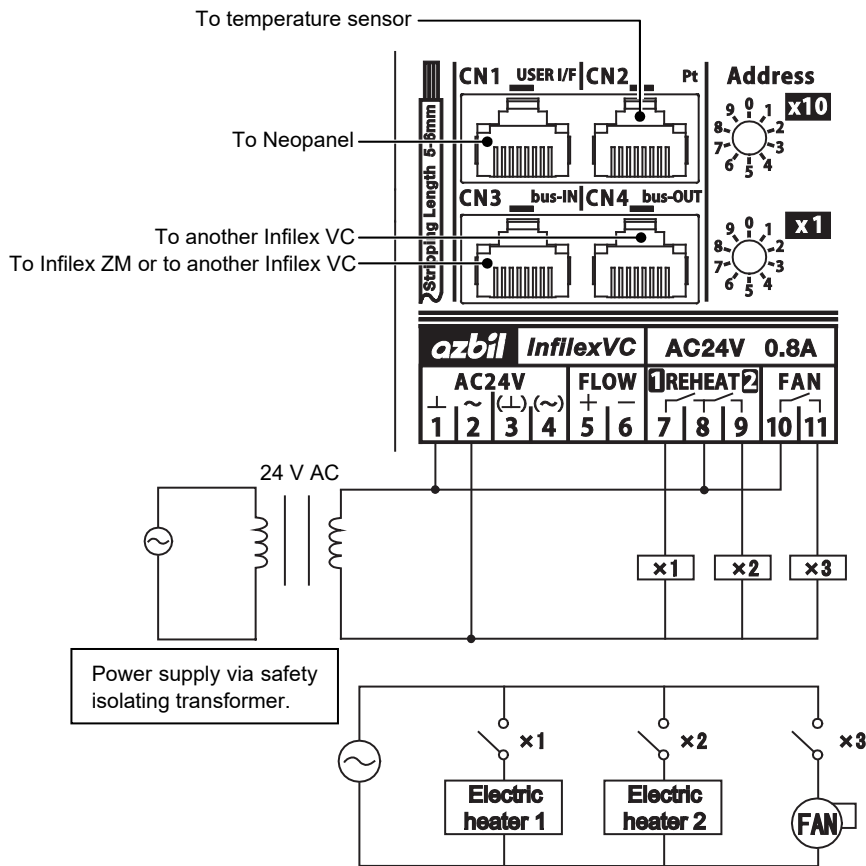

Figure 6. Wire connection indication printed on Model WY5206C5X30

Wire Connection Examples

Electric heater connection



Notes:

- * Operate electric heater and fan by a relay with 24 V AC operating voltage.
- * When an electric heater is connected, additionally provide a circuit to prevent temperature rise.

Figure 7. Connection example for two-step electric heater + fan output control (Model WY5206C5X30)

Floating control valve connection

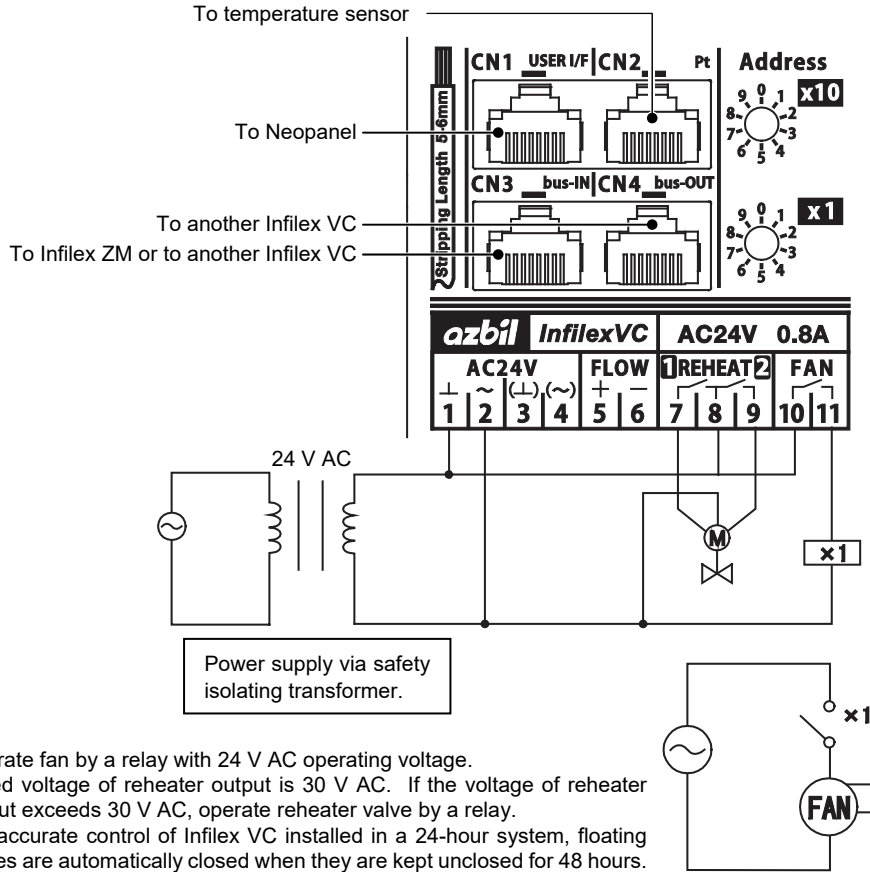

Figure 8. Wiring example for floating control (Model WY5206C5X30)

Two-step control valve connection

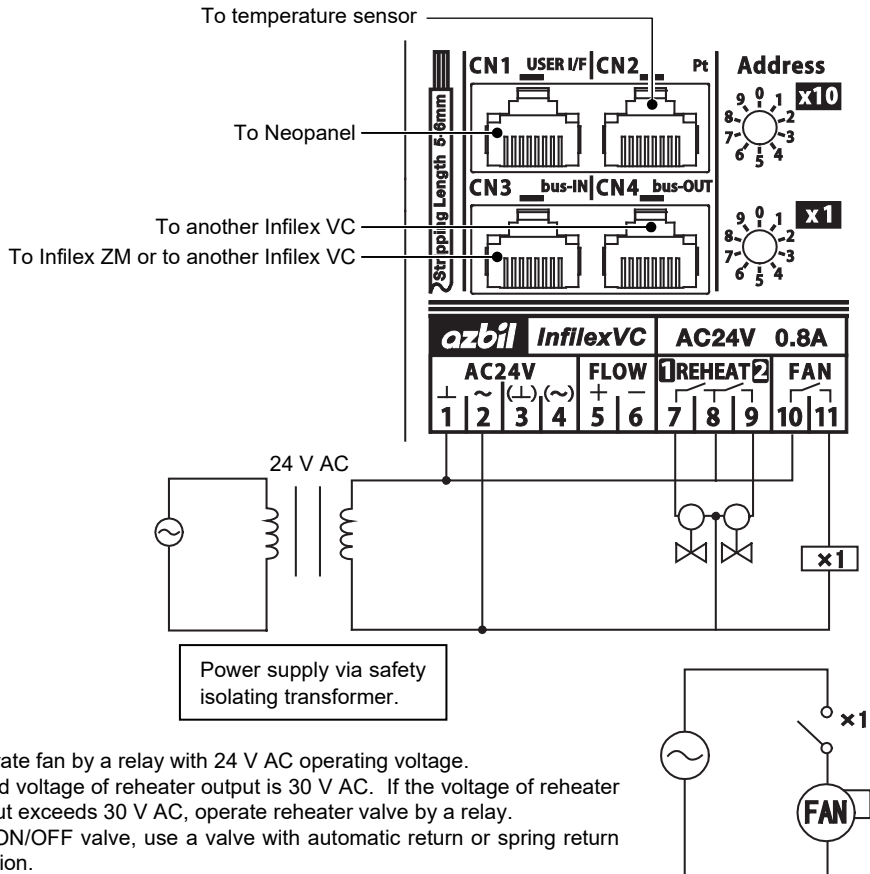
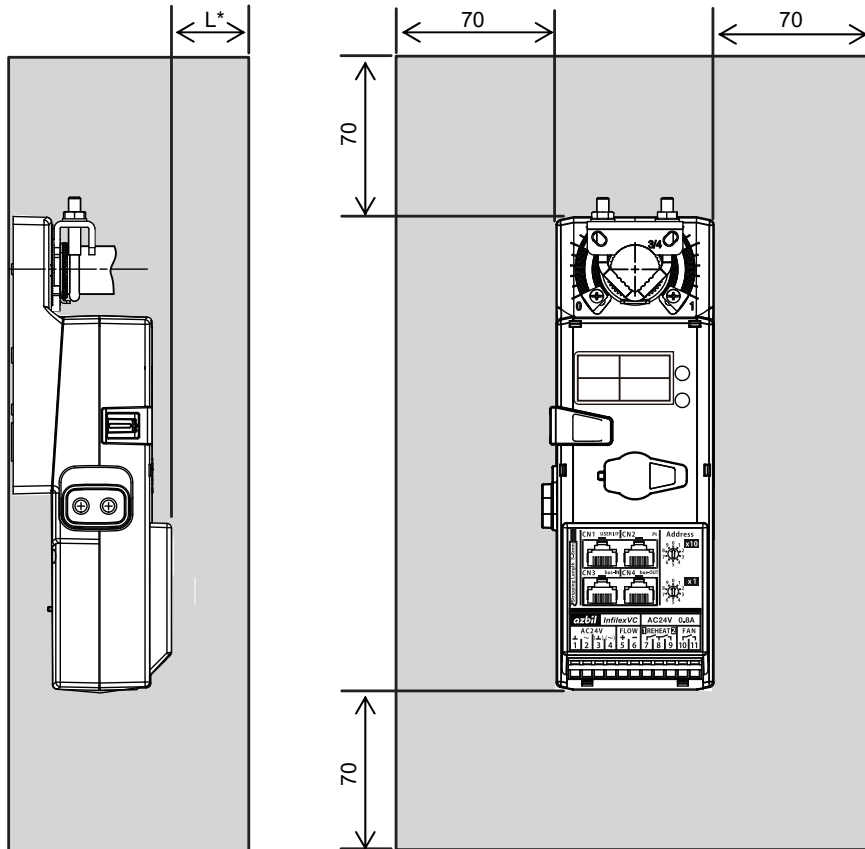

Figure 9. Wiring example for two-step control (Model WY5206C5X30)

Installation

Installation precautions

- Before installation, be sure to turn off the power to the product.
- Leave the maintenance clearance as shown in the figure below.



Note:

* Dimension L must be larger than [size Φ of the modular cables to be connected x 4] for the bend radius. (e.g., Dimension L for $\Phi 6$ mm modular cable is larger than 24 mm for bend radius.)

Figure 10. Maintenance clearance (mm)

Installation procedure

- 1) Fully close the VAV damper shaft.

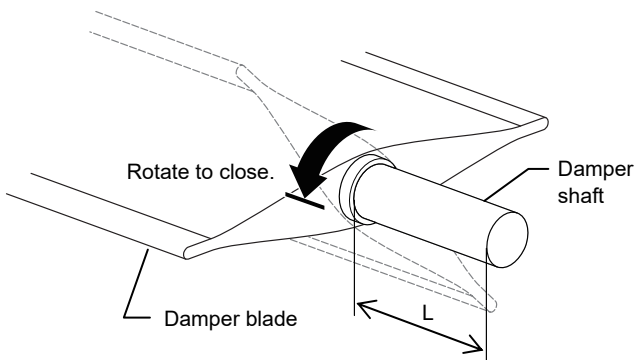



Figure 11. Damper shaft

Actuator torque type	L: Minimum length of the shaft (mm)	Diameter of the shaft (mm)	
			
5 N·m	37	6 to 20	4.5 to 14
10 N·m	40	8 to 26.7	5.7 to 18.8

- 2) Fully close the actuator of this product, and mount it to the damper shaft. Finger-tighten the fastening nuts of the shaft clamp to temporarily fix the actuator.

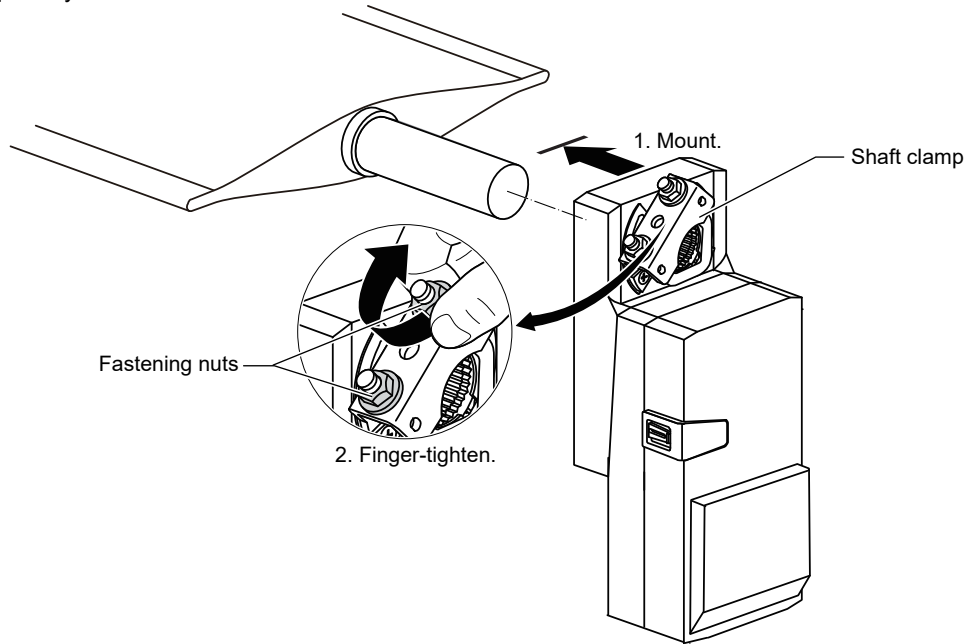
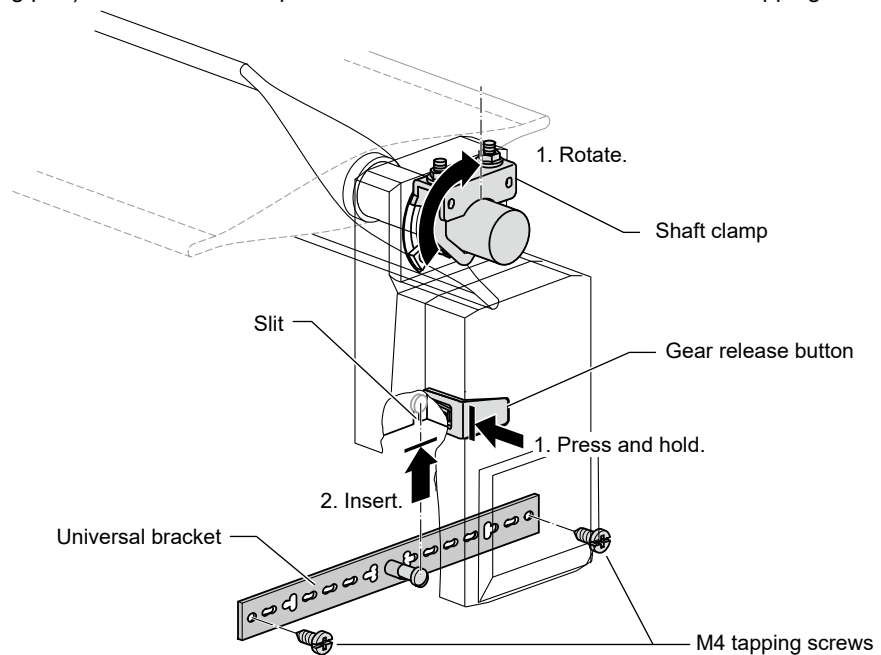

Figure 12. Temporal installation of the actuator body

- 3) While pressing the gear release button, manually rotate the shaft clamp until it is in the upright position. Then, insert the universal bracket (protruding part) into the slit of this product and fix the bracket with the two M4 tapping screws.



Note:

* The universal bracket, required for the installation of this product, is commercially available. The universal bracket is also available at Azbil Corporation (Universal bracket: Part No. 12595-00001). Be sure to separately order if necessary.

Figure 13. Attaching the universal bracket

- 4) Manually rotate the shaft clamp back to the fully closed position while pressing the gear release button. At this time, be sure to leave a clearance (approx. 1 mm) between the shaft clamp and the rotation angle adjuster (mechanical stopper) for the fully closed position. This will allow the actuator to shut off the damper. Using a wrench, tighten the fastening nuts of the shaft clamp to completely fix this product. See the following table for the nut fastening torque.

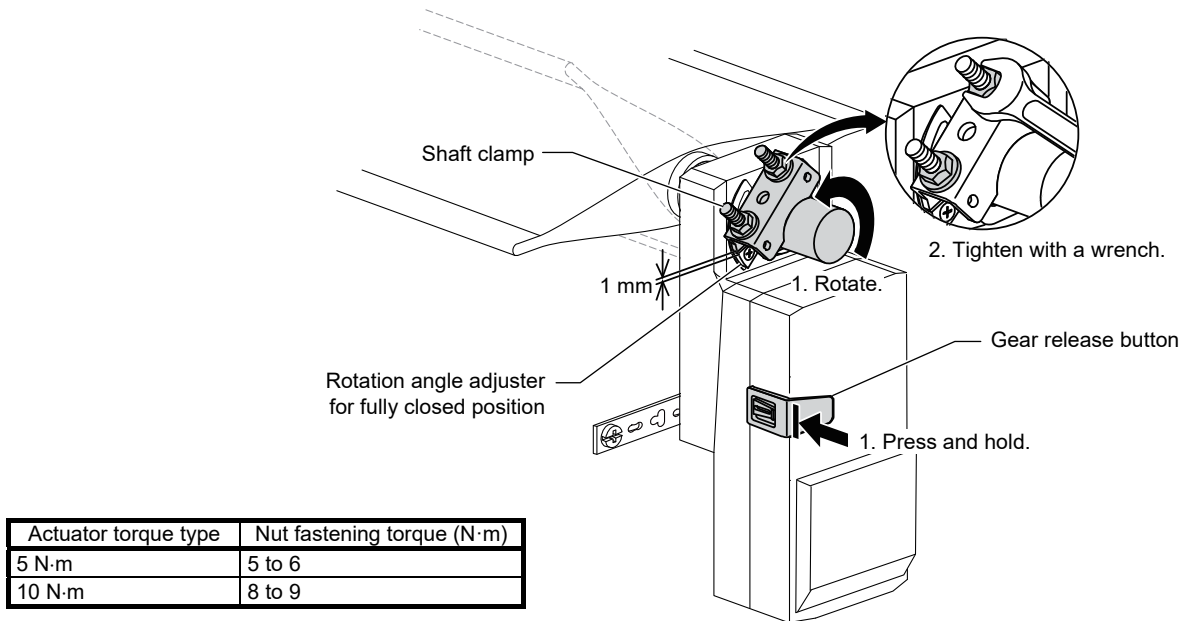

Figure 14. Complete installation of the actuator body

- 5) Manually rotate the shaft clamp to fully open the damper and set the rotation angle adjuster for the fully open position.

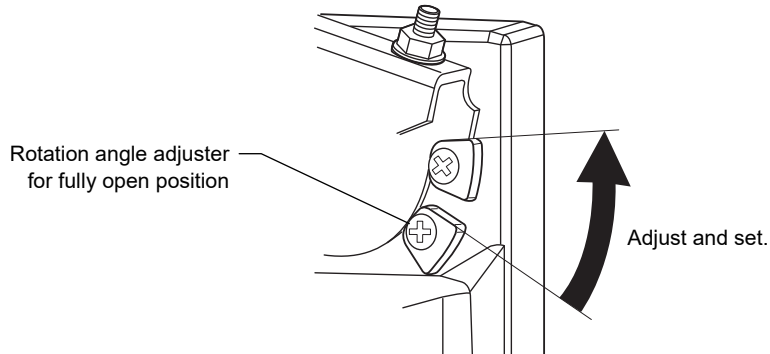

Figure 15. Setting the operating angle for the fully open position

Connection of the air flow sensor

For differential pressure pickup, connect the tube for the total pressure measuring port of the air flow sensor to the high pressure port (indicated with "+") of Inflex VC. Also connect the tube for the static pressure measuring port of the air flow sensor to the low pressure port (indicated with "-") of Inflex VC.

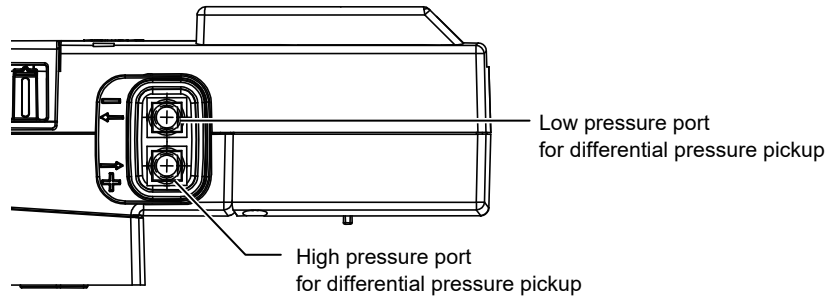

Figure 16. High and low pressure ports for differential pressure pickup (Model WY5206C5_10 and Model WY5206C5_30)

Required specification of the air flow sensor tube

Type	Length	Inner diameter	Outer diameter	Material
Flexible tube	Max. 1 m	5 mm to 6 mm	Max. 10 mm	PVC, silicon rubber
Inflexible tube		5.5 mm to 6.5 mm		

PVC: Polyvinyl chloride

Notes:

- * Use the tube as specified in the above table.
- * If the tube of the differential pressure pickup does not meet the required specification shown in the above table, use a joint to meet the specification.
- * Total tube length must be 1 m max. even if two tubes with different diameters are connected by the joint.

Wiring

Push-in terminal connection

Wires of power supply and DO (digital output) are connected to the push-in terminal block. Follow the procedure below for the wiring connections.

- 1) Strip the 5-6 mm insulation of the wire end. (If the insulation stripped part is longer than the specified, it will be exposed causing electric shock or short-circuit between adjacent terminals. If it is shorter, the wire may not contact the terminal.)
- 2) Make sure that any wire fiber is unbound from the wire end.
- 3) Insert a slotted screwdriver into a smaller square hole (for clamp release) on the terminal block located on the front surface. To insert the screwdriver to the deep end (approx. 10 mm deep), push and tilt it (towards the front surface of Inflex VC main unit) along the curving surface inside the square hole.

When the screwdriver is inserted to the deep end, the clamp is completely released.

Notes:

- * A slotted screwdriver with the blade 3.5 mm wide and 0.5 mm thick (straight type) is acceptable. A screwdriver with the blade tip narrower than the shaft may not be acceptable.
 - * Appropriate screwdriver (an example):
Model 9900 (3 mm wide ´ 100 mm long) or Model 910 (3 mm wide ´ 75 mm long) manufactured by Vessel Co., Inc.
 - * Since the terminal block has the inclined surface, required clearance for maintenance varies depending on the length of the screwdriver to be used.
- 4) Insert the wire end into a larger square hole. When the wire end is fully inserted, remove the screwdriver.
 - 5) Gently pull out the wire to make sure it is completely held by the clamp.

Wiring to user terminal / temperature sensor

SC-bus wiring

User terminal and temperature sensor are wired to Inflex VC with modular connection. SC-bus line is also connected with modular connection.

For correctly crimping modular plugs on a LAN cable, refer to the following.

Modular connector connection

Modular connector is composed of a modular plug (male) and a modular jack (female). Modular jacks are provided on Inflex VC, and modular plugs will be crimped on LAN cables as required. Refer to the following procedure for crimping the modular plugs on the LAN cables and connecting them to the modular jacks.

Note:

- * For modular plugs, refer to **Note *1** of the **Input/output specifications** section.

Procedure for modular connector connection

- 1) Strip the outer sheath of a LAN cable end. Be sure not to scratch or peel off any wire insulation when stripping the sheath.

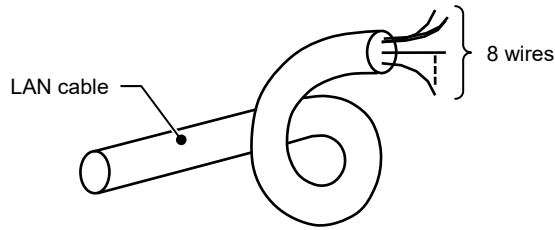

Figure 17. Stripping the sheath

Make sure there are eight wires inside the sheath.

- 2) Align the eight wires in the order specified by the LAN cable manufacturer. An alignment example of the LAN cable wires is shown in the table below.

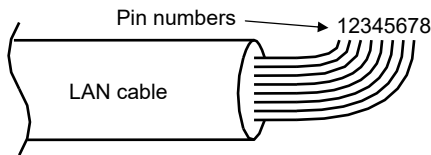

Figure 18. Alignment of the wires

Modular plug pin number	Wire alignment	Wire color code
		1
2	Line 1 of pair 2	Orange
3	Line 2 of pair 3	White and Green
4	Line 1 of pair 1	Blue
5	Line 2 of pair 1	White and blue
6	Line 1 of pair 3	Green
7	Line 2 of pair 4	Brown and white
8	Line 1 of pair 4	Brown

Note:

* The color alignment shown above may not agree with your LAN cable specification. Ask your LAN cable manufacturer for the latest specification.

- 3) Insert the aligned wires into a modular plug.

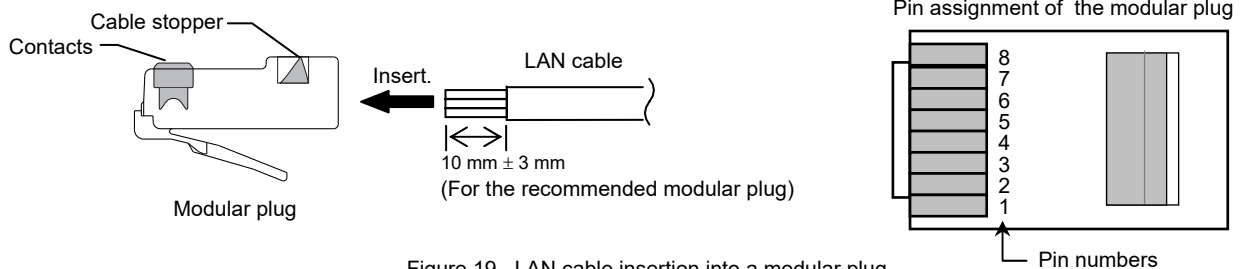

Figure 19. LAN cable insertion into a modular plug

Pin assignment of the modular plug in Fig. 19 is the image when the contacts and the cable stopper of the modular plug are viewed from above.

Before inserting the wires into the modular plug, even out the length using a nipper. Note that the modular plug may not be crimped on wires if the wire insulation is stripped too long.

- 4) Crimp the modular plug using a crimper. Insert the wires into the modular plug so that the contacts of the modular plug stick into the wires after crimping. Crimped modular plug is secured on the LAN cable by the cable stopper of the modular plug. Check the contacts and the cable stopper when crimping the modular plug.
- 5) Follow 1) to 4) for the other end of the LAN cable.
- 6) Check continuity of the LAN cable. Modular cable tester (Part No. DY7206A0000) facilitates the continuity check. At the same time, make sure that the wires are aligned in the specified order, the modular plug contacts stick into the wires, and that there is no cable damage or disconnection.
- 7) Connect the modular plugs to the modular jacks. After successfully finishing the continuity check, insert a modular plug of the LAN cable into the modular jack of Inflex VC and the other modular plug into the modular jack of the user terminal / temperature sensor / sub remote unit (also known as "sub controllers") connected via SC-bus.

Insert a modular plug until it clicks and gently pull the cable to check complete connection.

Software Details

(1/2)

Item	Function	Description	Remark
Operation	VAV ON/OFF	Turns on/ off the variable air volume (VAV) unit by operating the BMS client PC or the user terminal.	<ul style="list-style-type: none"> - Each Inflex VC can individually turn on/off the VAV unit. - The latest user terminal/BMS client PC operation is effective. - VAV ON/OFF function using the user terminal can be disabled by the BMS client PC. - Once VAV ON/OFF function is set, you can not turn on the <i>Setback</i> function with the user terminal. (The user terminal allows you to operate either VAV ON/OFF or VAV ON/Setback ON.)
	Setback	Adds/Subtracts the setback value to/from the set temperature. Changes the set temperature by operating the BMS client PC or the user terminal. The setback value is preset at Inflex VC.	<ul style="list-style-type: none"> - Each Inflex VC can individually change the set temperature for the <i>setback</i> operation. - The latest user terminal/BMS client PC operation is effective. - Setback function using the user terminal can be disabled by the BMS client PC. - Once <i>Setback</i> function is set, you can not turn off the VAV unit with the user terminal. (The user terminal allows you to operate either VAV ON/Setback ON or VAV ON/OFF.)
	Temperature setting	Changes the set temperature by operating the BMS client PC or the user terminal.	<ul style="list-style-type: none"> - The latest user terminal/BMS client PC operation is effective. - High/low limit of the setpoint is set by the BMS client PC. - Dual setting is available*2.
	VAV interlocking with air conditioning unit*1	Interlocks the ON/OFF operations of the VAV units with those of the air conditioning units.	<ul style="list-style-type: none"> - One Inflex ZM controls up to 4 AHU groups. - Do not operate VAV ON/OFF with the user terminal when you set the VAV <i>interlocking with air conditioning unit</i> function. - Do not set the <i>air conditioning unit interlocking with VAV</i> function when you set the VAV <i>interlocking with air conditioning unit</i> function.
	Air conditioning unit interlocking with VAV*1	Interlocks the ON/OFF operations of the air conditioning units with those of the VAV units.	<ul style="list-style-type: none"> - One Inflex ZM controls up to 4 groups. - Do not set the VAV <i>interlocking with air conditioning unit</i> function when you set the <i>air conditioning unit interlocking with VAV</i> function.
Control (1/2)	Temperature control	Controls VAV damper to meet the actual (measured) temperature with the set temperature.	Each Inflex VC can individually controls the VAV damper.
	Fan speed control*1	Detects over/short static pressure of the VAV unit and optimally controls the revolution speed of the supply air fan to minimize the fan power.	<ul style="list-style-type: none"> - One Inflex ZM controls up to 4 groups. - AHU controller and Inflex ZM must be connected to the same NC-bus line.

AHU: Air handling unit
 BMS: Building management system
 VAV: Variable air volume

Notes:

*1 These functions are enabled by Inflex VC being combined with Inflex ZM and integrated in our BMS.

*2 Dual setting is the method to have cooling setting and heating setting separately.

Item	Function	Description	Remark
Control (2/2)	Optimum temperature control of supply air* ¹	Controls the supply air temperature of the air conditioning unit at the optimum level to provide comfort and to save energy.	- One Inflex ZM controls up to 4 groups. - AHU controller and Inflex ZM must be connected to the same NC-bus line.
	Mixing loss control* ¹	Sets the difference between the set temperature of the perimeter air conditioning unit and the interior air conditioning unit that are interlocked. This prevents the mixing loss.	- One (group of) Inflex VC interlocks with another (group of) Inflex VC and/or Inflex FC. - Slave Inflex VC and/or Inflex FC can not interlock with a different Inflex VC and/or Inflex FC. - Do not operate the slave Inflex VC and/or Inflex FC with the user terminal.
	Parallel operation of multiple VAV* ¹	Concurrently turns on/off the multiple VAV units or changes fan speed of the multiple VAV units (supply air VAV unit and return air VAV unit).	- One-to-one Inflex VC or one-to-multiple Inflex VC are interlocked. - For the parallel operation, Inflex VC must be connected to the same SC-bus line.
	Fan powered control	Turns on/off the fan of the VAV unit with fan to maintain enough airflow.	Fan output corresponds with heating/cooling conditions and each fan type. - Series fan: Fan is ON when VAV unit is ON. - Parallel fan (for temperature): Fan is ON when VAV unit is ON in heating mode. - Parallel fan (for air volume): Fan is ON when VAV unit is ON in heating mode with low airflow.
	Reheat control* ¹	Enables the heating mode by electric heater or hot water valve.	- Electric heater and ON/OFF valve allow up to two-position control. Floating valve allows single-position control. - Reheat control is forcibly performed by operating the BMS client PC (manual override function).
Monitoring (with the BMS client PC)	Individual monitoring* ¹	Monitors and controls the point data (measuring, setting, operation, and control data) of Inflex VC from the BMS client PC. The following are examples of the point data for individual monitoring: VAV ON/OFF, VAV failure, room temperature, cool setting/main setting, heat setting, heat high limit/set high limit, cool low limit/set low limit, setback, re-heater output, fan output, measured air volume, max. air volume, damper position (Not all of the items above are required to monitor or control with the client PC.)	
	Group monitoring* ¹	Forms a group of multiple Inflex VC, monitors and controls the following point data of the grouped Inflex VC through the BMS client PC: VAV ON/OFF, VAV failure, room temperature* ³ , cool setting/main setting, heat setting, heat high limit/set high limit, cool low limit/set low limit, setback (Not all of the items above are required to monitor or control with the client PC.)	- All of Inflex VC connected from a single Inflex ZM are divided into up to 25 groups. (Various grouping is available.) - The point data for the group monitoring cannot be individually monitored. - Both of the group monitoring and the individual monitoring can be applied to the grouped Inflex VC. (e.g., VAV ON/OFF for group monitoring and room temperature for individual monitoring)
	Batch operation* ¹	Forcibly sets the airflow of all the VAV units (that are included in each air conditioning unit group) at the maximum or minimum volume by operating the BMS client PC.	- One Inflex ZM controls up to four groups. - Batch operation is enabled with Inflex ZM as well as with the BMS client PC.

BMS: Building management system

VAV: Variable air volume

Notes:

*1 These functions are enabled by Inflex VC being combined with Inflex ZM and integrated in our BMS.

*3 Room temperature for the group monitoring calculates either the average value in a group or the representative value of a group.

LED Indication

After the power is applied to Inflex VC, check that the status indicator LED blinks in approx. 10 seconds. If it stays ON, Inflex VC is in abnormal status. Note that the LED stays ON immediately after the power is applied to Inflex VC, which does not indicate error.

For the description of LED indications, refer to Fig. 21.

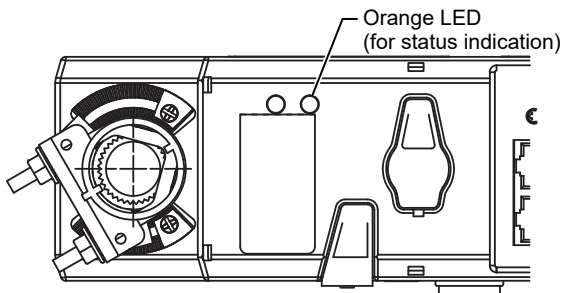

Figure 20. LED location

Status	LED indication (□: ON / ■: OFF)
Normal	Normal
Power OFF	Power Off
SC-bus error	SC-bus Error
Initializing / Error	Error 1
Minor error	Error 2

Figure 21. Description of LED indication

IMPORTANT:

Do not press the LED button. Operation of Inflex VC will be stopped, and the automatic operation mode will switch to the adaption mode. (Inflex VC will fully close and open the VAV damper.)

Setting

The following settings must be performed by a technical engineer.

- Address setting
 Two address setting switches are located on the front surface of Inflex VC. The switch with "X10" indicates tens of the address, and the switch with "X1" indicates ones of the address.
 For setting the address, use the slotted screwdriver used for the wiring connection. (See the **Push-in terminal connection** section.)
- Parameter setting
 Inflex VC parameters are set in response to the size and type of VAV unit, room characteristics, and applications.
 For setting the parameters, our engineering tool is required.

To Connect Two User Terminals (for Remote Control)

Up to two digital user terminals (Neopanel Model QY7205) can be connected to one Inflex VC.

To connect the two user terminals, the following are required.

- Modular branch unit (Model DY7203A0000)
 See the **Optional Parts** section for details.
- Neopanel with address 1 and with address 2
 (Note that two Neopanel with address 1 connected to the Inflex VC will not work.)

For two Neopanel connection, provide Model QY7205CXXX1 for the address 1 and Model QY7205CXXX2 for the address 2. Address number is indicated on the shipping carton and on the label attached to the inside surface of the Neopanel main unit (with the base cover removed).

Notes:

- * The latest VAV unit ON/OFF operation or temperature setting operation with a Neopanel or with the BMS client PC is effective.
- * Neopanel with address 2 (Model QY7205CXXX2) does not have the temperature measuring function.

Optional Parts

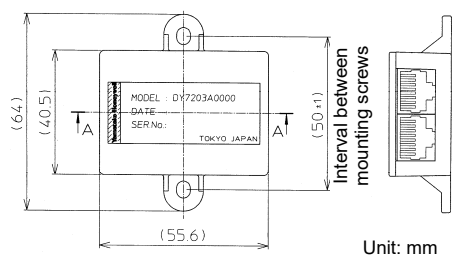

Figure 22. Modular branch unit: Part No. DY7203A0000

Modular branch unit (See Fig. 22):
Used to branch out the communication line for two user terminals to be connected.

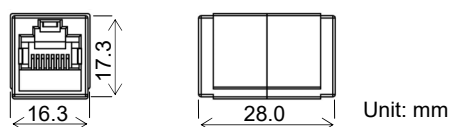

Figure 23. Modular relay unit: Part No. DY7202A0000

Modular relay unit (See Fig. 23):
Used to extend the communication line by connecting to another communication line.

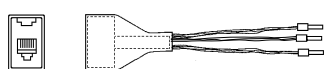

Figure 24. Adapter for connecting to a Pt100 temperature sensor: Part No. DY7204A0003

Adapter for connecting to a Pt100 temperature sensor (See Fig. 24):
Used to connect a temperature sensor to Inflex VC with a modular connector.

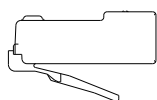

Figure 25. Modular plug: Part No. DY7207A0100

Precautions for use

- Modular branch unit, modular relay unit, adapter for connecting to a temperature sensor, and adapter for connecting to a user terminal must be used in an outlet box or inside a panel.
- For the modular connector connection, be sure to insert the modular plugs into the modular jacks until they click. Then, lightly pull out the cables to make sure they are completely connected.

Optional Tools



Modular crimper (See Fig. 26.):
Used to crimp a modular plug on a LAN cable.

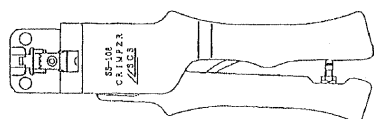

Figure 26. Modular crimper: Part No. DY7205A0002

Modular continuity tester (See Fig. 27.):
Used to check continuity of a LAN cable with modular plugs crimped on.

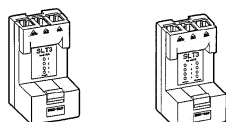

Figure 27. Modular cable tester: Part No. DY7206A0000



This product complies with the essential requirements of the Electromagnetic Compatibility Directive (EMCD) and the Restriction of Hazardous Substances Directive (RoHSD).

EMCD: EN 61000-6-2

EN 61000-6-3

Inflex, PARAMATRIX, and savic-net are trademarks of Azbil Corporation in Japan or in other countries.

BACnet is a registered trademark of American Society of Heating, Refrigerating and Air-Conditioning Engineers (ASHRAE).

TYGON is a trademark of Saint-Gobain Performance Plastics Corporation.

The image shows the 'azbil' logo in a bold, lowercase, italicized sans-serif font.

Specifications are subject to change without notice.

Azbil Corporation
Building Systems Company

<https://www.azbil.com/>