

Inflex™ GC

Multipurpose Controller

Model WY5311

General

Inflex GC (Inflex: named for “Infinity” and “Flexible”) Model WY5311 is a multipurpose controller designed to control building equipment, such as air handling unit (AHU). Inflex GC enables to control the temperature and humidity, as well as building equipment operation.

Inflex GC can be operated with a user terminal and with Operator Panel. Besides, Inflex GC can communicate with BMS (building management system) Azbil Corporation’s savic-net™ FX via LonTalk® protocol. By sending the operation status to the main control unit (monitoring computer) and by controlling the operation based on the commands sent from the main control unit, the integrated control of the entire building can be executed.

Inflex GC consists of a basic unit and connectable I/O modules (and a user interface module). The number and types of the modules can be flexibly changed corresponding to the control or management to fit in various applications. Additionally, since the software to be installed can be freely edited, an optimum application for building equipment can be configured in terms of both the software and hardware.



Features

- **Compact design:**
Small size body allows free installation in a desired place.
- **Various input/output (I/O) configurations:**
Input and output types can be selected, and the number of points to be mounted can be increased or decreased corresponding to the application.
- **Editable software configurations:**
Optimal software for the contents of the application can be configured.
- **User interface module (Operator Panel):**
Operator Panel (panel mount type/integral type) connected to Inflex GC allows you, without changing the settings from the BMS center unit, to change the Inflex GC settings.
- **Remote control with a user terminal:**
Neopanel™ or Neoplate is connectable, so that a user at a remote location can perform ON/OFF operation and change temperature setting.
- **Autonomous distributed control:**
Even if a trouble occurs in the BMS, the backup operation is performed individually to distribute potential risks caused by malfunction of the system.
- **Installation:**
A quick-fit screwless (clamp) terminal block is used for the communication terminal block of the I/O module, ensuring the labor saving of the wiring work. Additionally, either DIN rail mounting or screw mounting can be selected.
- **LONMARK® certified product:**
Inflex GC is LONMARK® certified and thus interoperable integrated in the LONWORKS® system.
- **CE Marking certified product:**
Inflex GC conforms to all the applicable standards of CE Marking (Class A).



* Azbil Corporation’s Inflex series controllers: Inflex is named for “Infinity” and “Flexible.”

Safety Instructions

Please read instructions carefully and use the product as specified in this manual. Be sure to keep this manual near by for ready reference.

Usage Restrictions

This product is targeted for general air conditioning. Do not use this product in a situation where human life may be affected. If this product is used in a clean room or a place where reliability or control accuracy is particularly required, please contact Azbil Corporation's sales representative. Azbil Corporation will not bear any responsibility for the results produced by the operators.

WARNING



- DANGER: To prevent the risk of severe or fatal electrical shock, always disconnect power source and product power supply before performing any wiring.



- Be sure to ground with 100 Ω or lower ground resistance. Improper grounding may cause electrical shock or equipment damages.



- Do not detach the terminal cover at any time except when wiring. After wiring, be sure to attach the terminal cover. Before attaching/detaching the terminal cover, make sure that the wires are not current-carrying to prevent electrical shock.



- Disconnect power before the product replacement to prevent electrical shock.



- Do not disassemble the product. Disassembly may result in electrical shock or equipment damage.

CAUTION



- Installation and wiring must be performed by qualified personnel in accordance with all applicable safety standards.



- This product must be operated under the operating conditions (power, temperature, humidity, vibration, shock, installation position, atmospheric condition, etc) specified in this manual to prevent equipment damages.



- All wiring must comply with local codes of indoor wiring and electric installation rules.



- Use crimp terminal lugs with insulation for electric wires connected to the screw terminals.



- Connect cables to the power source with terminals or the like for permanent connection.



- Make sure all the wires are tightly connected to prevent heat generation or equipment damages.



- If more than the rated power supply voltage is applied, product replacement is required for safety.



- Install this product in a location out of reach of unauthorized people. (e.g. Inside of the control panel cabinet)



- Lightning protection based on regional characteristics and building structure is needed in order to minimize lightning damages.



- Noise protection is necessary when the product is installed in a location close to many noise sources.



- Do not block the vent holes of the product to prevent equipment damages. Remove protective sheet after installation and wiring.



- After mounting the product on DIN rail, make sure that the holding parts of all the modules are properly fixed with their whole parts lifted. The product may drop from the DIN rail and be damaged due to improper mounting.



- Do not plug in or out I/O modules or user interface modules with the product power turned on to prevent equipment damages.



- Dispose of the lithium battery in accordance with your local regulations.



- Dispose of this product in accordance with your local regulations. Do not reuse all or part of this product.

Trademark information:

Inflex, Neopanel, PARAMATRIX and savic-net are trademarks or registered trademarks of Azbil Corporation in Japan or in other countries.

BACnet is a registered trademark of American Society of Heating, Refrigerating and Air-Conditioning Engineers (ASHRAE).

CompactFlash is a U.S. registered trademark of SanDisk Corporation.

KPEV is a registered trademark of Furukawa Electric Co., Ltd.

LONMARK, LonTalk, and LONWORKS are trademarks of Echelon Corporation registered in the United States and other countries.

System Configurations

Infilex GC integrated into BMS: savic-net™ FX

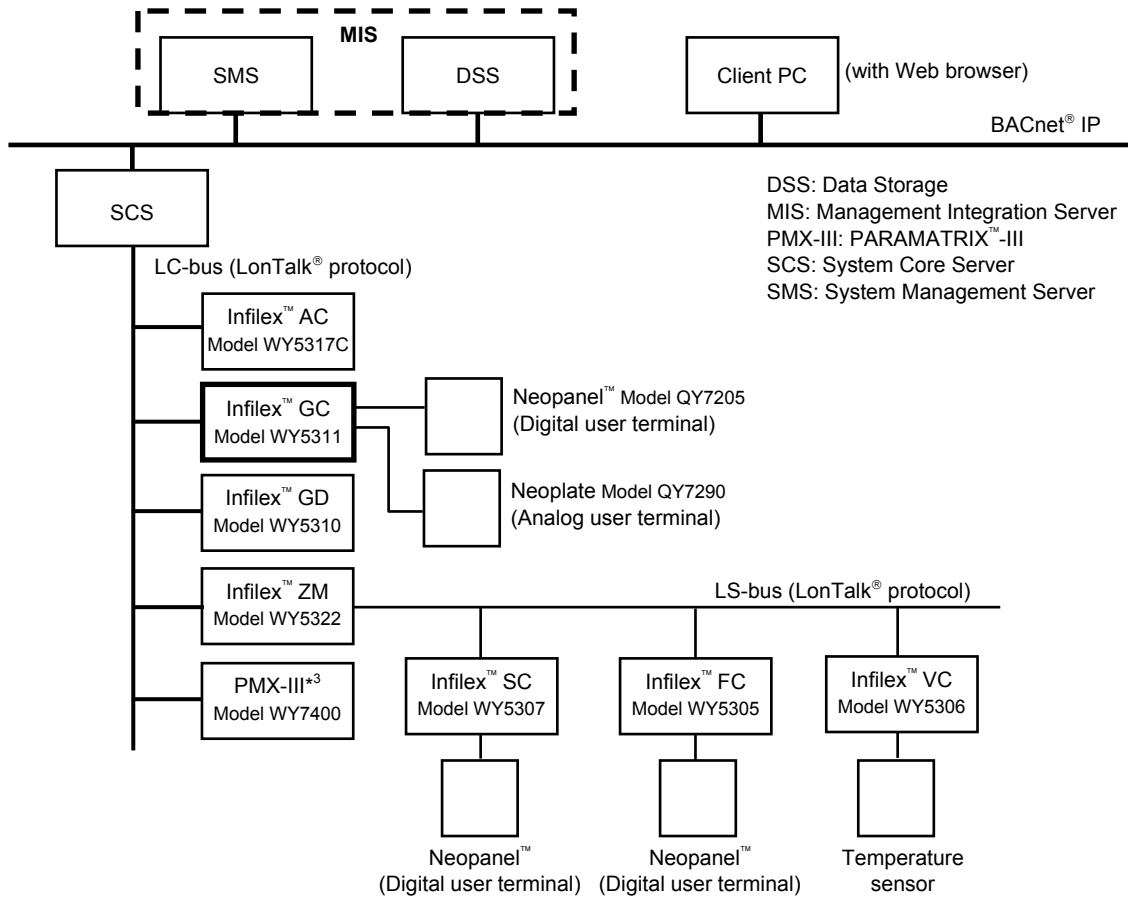

Figure 1. System configuration example of BMS-integrated Infilex GC

Notes:

- * MIS may be used instead of SMS and DSS for your system. Note that MIS cannot be mixed with SMS or DSS in the same system.
- * On 1 channel of LC-bus (2 lines for 1 channel), max. 50 remote units (also called 'controllers') can be connected. For Infilex ZM, however, max. 10 units can be connected on LC-bus (5 units per 1 line, 2 lines for 1 channel).
- * Max. wiring length of LC-bus (2 lines for 1 channel) is 900 m.
- * On LS-bus, max. 50 remote units (also called 'sub-controllers') can be connected.
- * Max. wiring length of LS-bus is 900 m.

Standalone Infilex GC

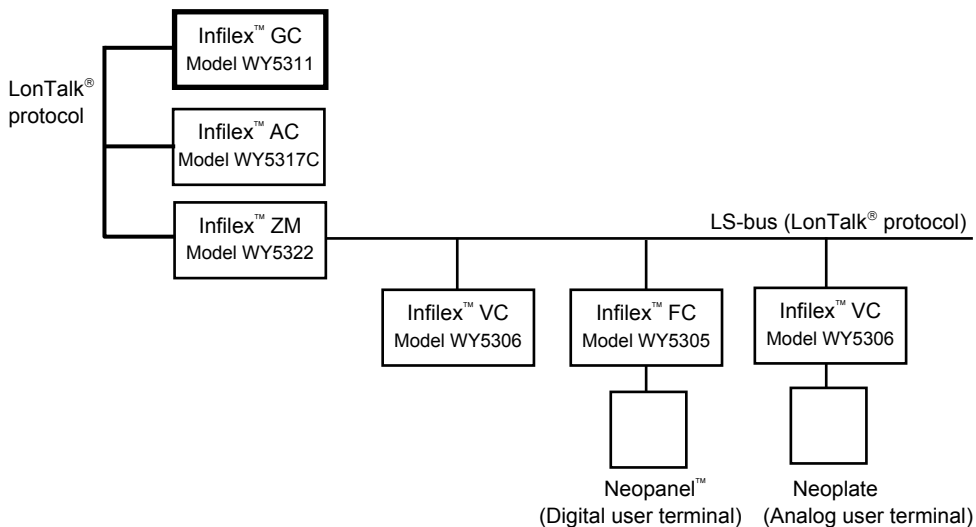

Figure 2. System configuration example of standalone Infilex GC

Notes:

- * On LS-bus, max. 50 controllers can be connected.
- * Max. wiring length of LS-bus is 900 m.

Model Numbers

Model number		Description
WY5311		Base model number
	W	100 V AC to 240 V AC power
		0000 Fixed

Notes:

- * For I/O modules and user interface modules (UT module and integral type Operator Panel) to be combined with Inflex GC Model WY5311, separate order is required.
- * Regarding I/O modules user interface modules to be combined with Model WY5311, refer to AB-6527 Specifications/Instructions of Model RY50XX.

Parts for Installation

For details regarding Inflex GC installation, refer to Installation manual of the Inflex series controllers

Part number	Description
83165861-001	Screw tab
83104567-001	DIN rail mounting bracket

Note:

For mounting Inflex GC, either the screw tab (for screw mounting) or the DIN rail mounting bracket (for DIN rail mounting) is required. Be sure to separately order depending on your mounting type.

Specifications

Basic specifications

Item		Specification	
Power supply		Rated voltage	100 V AC to 240 V AC, 50 Hz/60 Hz
		Allowable voltage range	85 V AC to 264 V AC, 50 Hz/60 Hz
		Power shutdown detection	80 V AC or less
		Power consumption	40 VA
Environmental conditions	Rated operating conditions	Ambient temperature	0 °C to 50 °C
		Ambient humidity	10 %RH to 90 %RH (non-condensing)
		Altitude	2000 m or lower
		Vibration	Max. 3.2 m/s ² at 10 Hz to 150 Hz
	Transport/storage conditions	Ambient temperature	-20 °C to 60 °C
		Ambient humidity	5 %RH to 95 %RH (non-condensing)
		Vibration for storage	Max. 3.2 m/s ² at 10 Hz to 150 Hz
		Vibration for transportation	Max. 9.8 m/s ² at 10 Hz to 150 Hz
LED indication	Operation	Power supply (POWER)	Green LED ON: Power ON Green LED OFF: Power OFF
		Major failure (ERR1)	Red LED ON: Major failure or system restart Red LED OFF: Normal operation
		Minor failure (ERR2)	Red LED ON: Minor failure or system restart Red LED OFF: Normal operation
		Communication	LC-bus
	Power failure backup	RAM, RTC*	Lithium battery backup
		Data file	Non-volatile memory (flash memory) backup
Communications	LC-bus	Transmission system	LonTalk protocol (TP/FT-10 transceiver)
		Transmission speed	78 kbps
		Transmission distance	900 m (for bus topology connection)
		Remote units	Max. 50 remote units connectable
Weight		400 g	
Material (housing), color		Modified PPE, light gray	
Terminals connection	Power supply, ground	M3 (7.62 mm pitch between terminals)	
	LC-bus communication	Modular connector	

Note:

* RTC: Real Time Clock. RTC is backed up by a lithium battery to ensure accurate clocking while the power is OFF.

Wiring specifications

Basic unit

Item	Wiring* ¹	Wiring length	Condition
Power supply* ²	JIS* ³ IV2.0 mm ² or JIS CVV 2.0 mm ² or greater	—	—
Ground* ²	JIS IV 2.0 mm ² or JIS CVV 2.0 mm ² or greater	—	Ground resistance: 100 Ω or lower
LC-bus	EIA/TIA-568 category 5 or over (φ0.5 × 4 poles)	900 m	For bus network topology

Notes

*1 Pin terminal is not applicable to wiring of Inflex GC.

*2 M3 screw terminal block is provided for wiring of power supply and ground. Be sure to crimp the crimp terminal lugs on the wire ends.

*3 JIS: Japanese Industrial Standards

I/O module

Item	Wiring	Wiring length
Temperature input	JIS IV, JIS CVV, KPEV®* 1.25 mm ²	100 m
Voltage/Current input	JIS IV, JIS CVV, KPEV® 1.25 mm ²	100 m
Voltage/Current output	JIS IV, JIS CVV, KPEV® 0.9 mm ² , 1.25mm ²	100 m
Modutrol motor output	JIS IV, JIS CVV, KPEV® 1.25 mm ²	100 m
Digital input	JIS IV, JIS CVV, KPEV® 0.5 mm ² , 0.75 mm ² , 0.9 mm ² , 1.25 mm ²	100 m
Relay output	JIS IV, JIS CVV, KPEV® 1.25 mm ²	100 m
Remote control relay output	JIS IV, JIS CVV, KPEV® 1.25 mm ²	100 m

Notes:

- * Since a quick-fit screwless terminal block is provided on I/O modules, the wires can be connected only by stripping the sheath. Sheath stripped length: 8 mm (Pin terminal cannot be used.)
- * KPEV is a wiring standard provided by Furukawa Electric Co., Ltd.

Specifications of I/O modules, user interface modules, and Operator Panel

For the specifications of I/O modules and user interface modules, refer to Specifications/Instructions of Model RY50XX (AB-6527). For the specifications of Operator Panel (integral type / panel mount type), refer to Specifications/Instructions of Model RY5001Q/QY5100W (AB-6546).

CE Marking Conformity

This product must be installed in a panel cabinet. Besides, the product in the panel cabinet must be out of reach of unauthorized people who are not well-trained for electric facilities.

This product complies with the following Electromagnetic Compatibility (EMC) and the Low Voltage Directive (LVD).

EMC: EN61326-1 Class A, Table 2 (For use in an industrial electromagnetic environment)

LVD : EN61010-1 Overvoltage category II

Pollution degree 2

Input/Output Terminal Arrangement

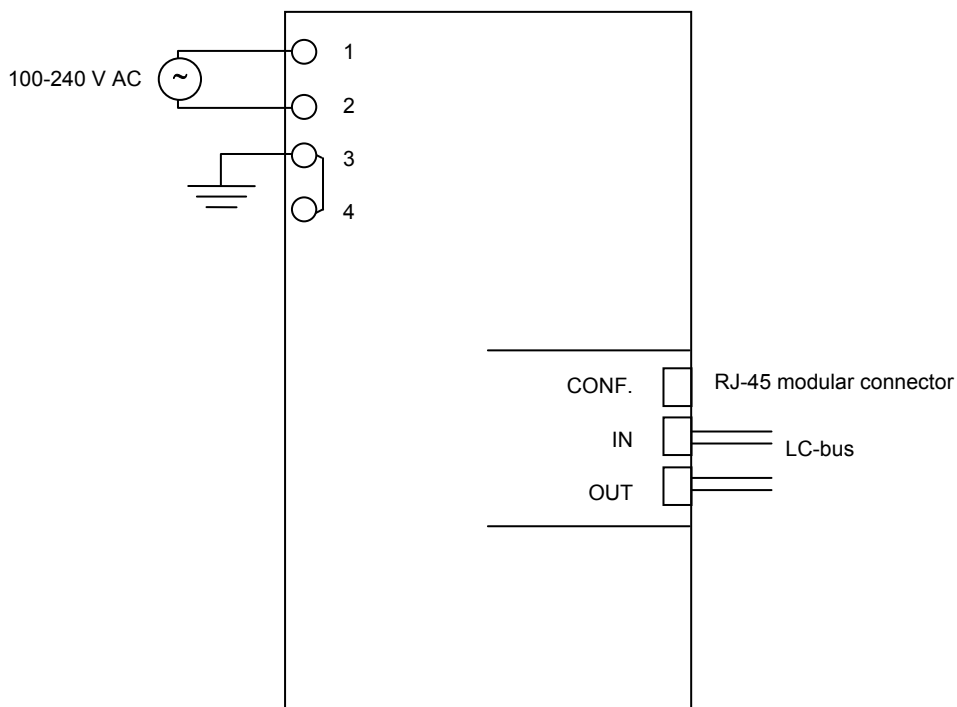

Figure 3. Input/output terminal arrangement

Dimensions

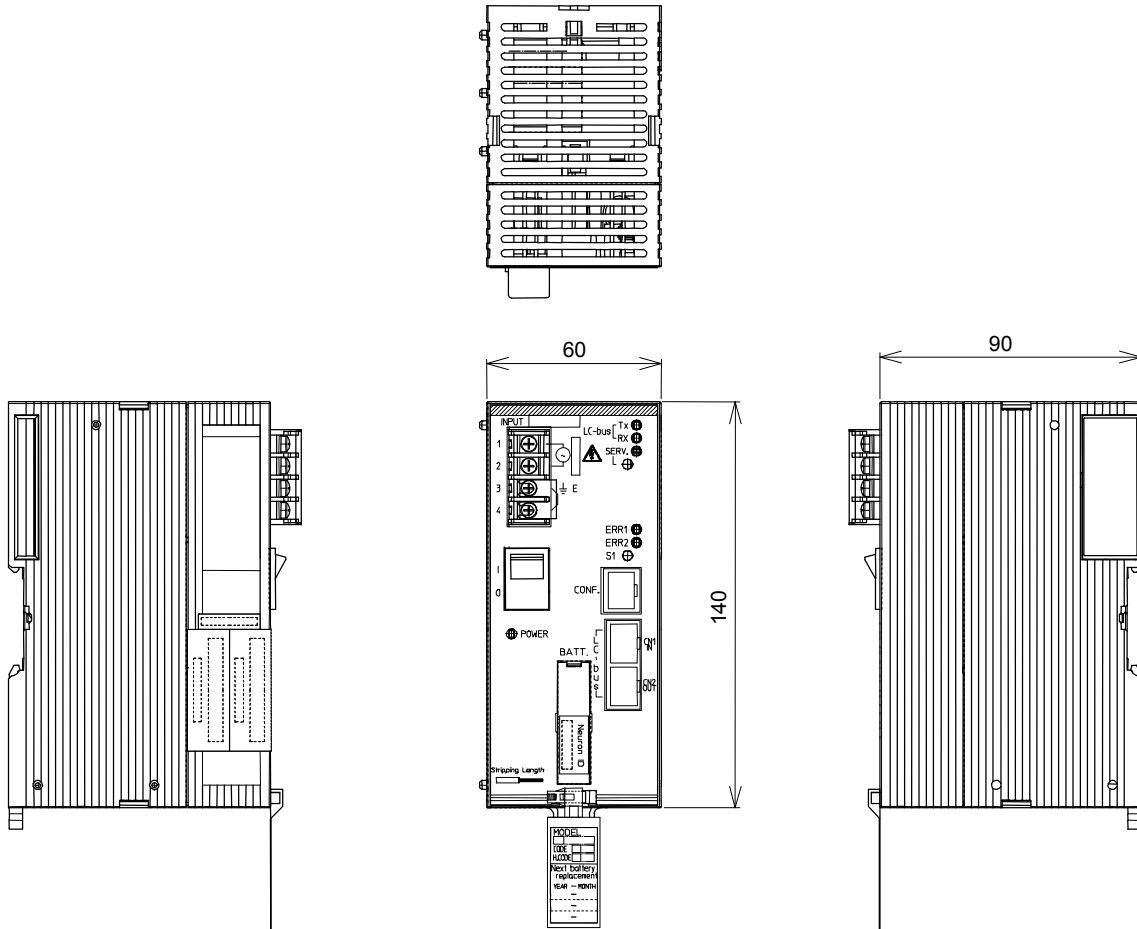

Figure 4. Dimensions (mm)

Parts Identification

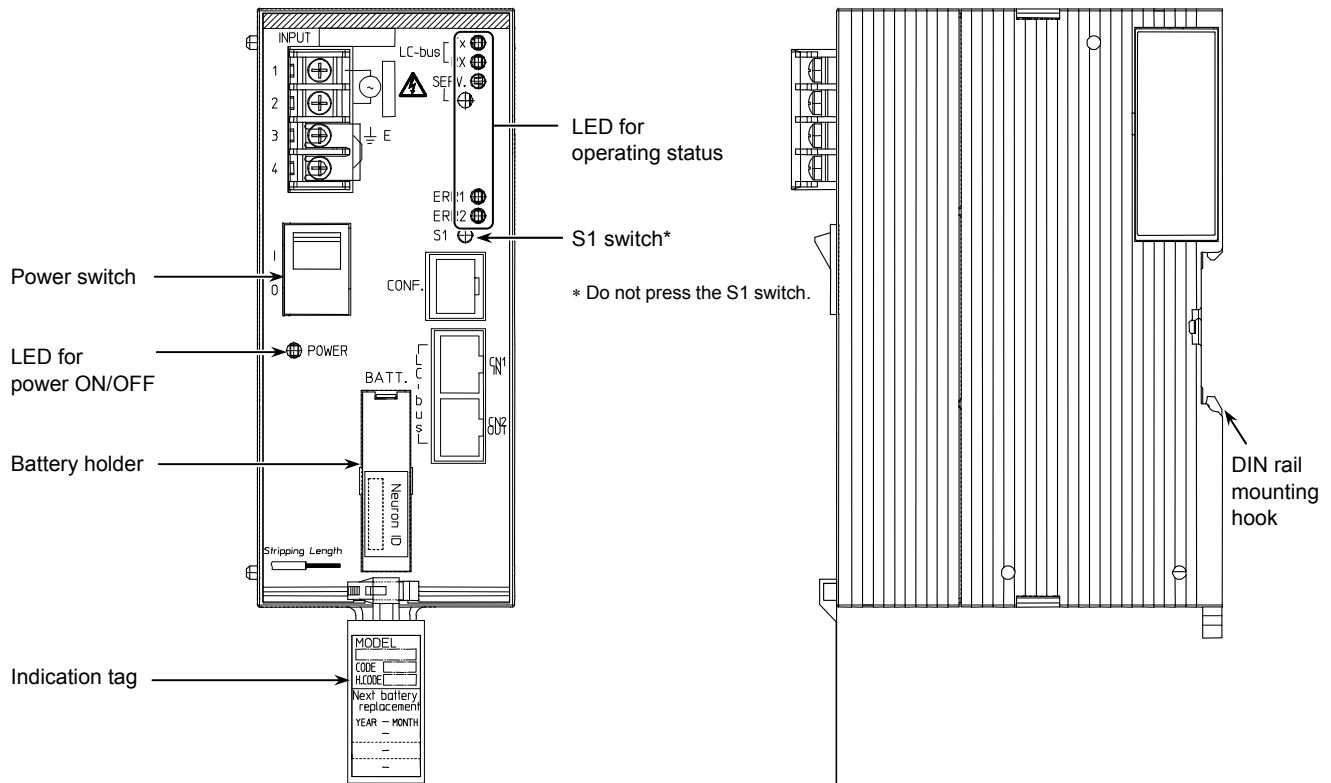

Figure 5. Parts identification

Table 1. Indication and operation of operating status LED

LED indication	LED operation
Data transmitting	LC-bus TX LED: flashing
Data receiving	LC-bus RX LED: flashing
In SERVICE mode	SERV LED: ON (See Table 2 for SERV LED operation.)
Major alarm / initializing	ERR1: ON
Minor alarm / initializing	ERR2: ON

Table 2. Indication and operation of SERV LED

Status	LED indication (□: ON / ■: OFF)
Normal	Normal
Applicationless	Appli-less
Unconfigured	Unconfig
LS-bus error	Any indication other than the above.

Connection of Data Setter for LonTalk Protocol

Connect the CompactFlash® memory type Data Setter (Model QY5111B) for LonTalk protocol to LC-bus port or to CONF. port of Infilex GC with the Data Setter adaptor (Part No. DY5301S0000, with separate order required.).

For details of the Data Setter adaptor, refer to its Specifications manual.

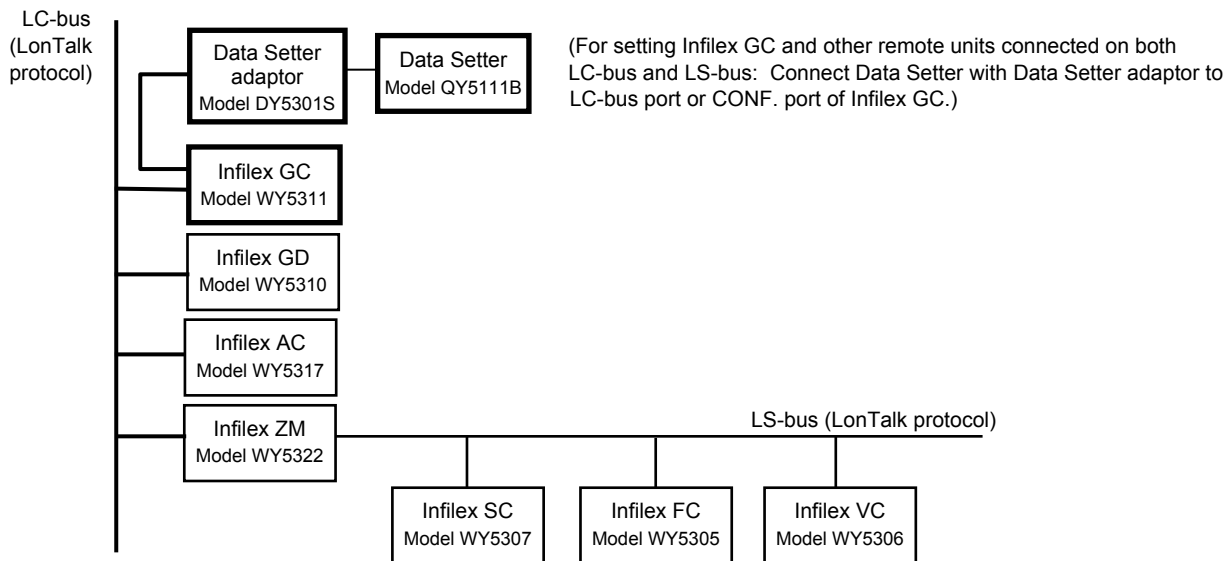

Figure 6. Connection example of Data Setter with Data setter adaptor to LC-bus port/CONF. port

Maintenance (Lithium Battery Replacement)

Replace the lithium battery for backup (Part No. 83104934-001) for every 5 years.

- IMPORTANT:**
- Since the remaining battery capacity cannot be checked by measuring the terminal voltage, be sure to replace the battery every 5 years.
 - Only authorized service personnel is allowed to replace the battery.
 - Do not touch the power supply unit when replacing the battery.
 - Replace the lithium battery every 5 years if the product is always in use (in ON state).
 - Replace the lithium battery with the power ON.
 - If the product has never or hardly been operated (in OFF state) for a year, replace the lithium battery before the product operation.

Battery replacement

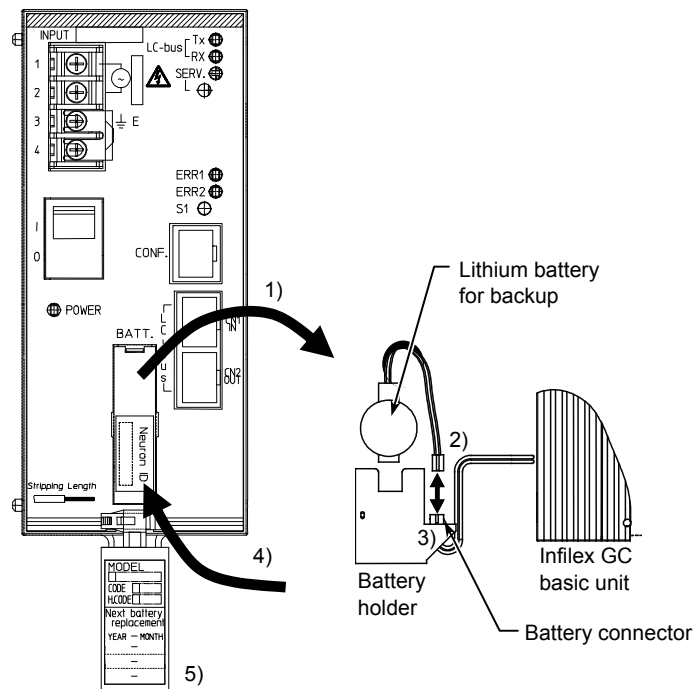

* Replace the lithium battery with Inflex GC in ON state.

Figure 7. Battery replacement

- 1) Pull out the battery holder using a slotted screwdriver.
- 2) Disconnect the battery connector and detach the lithium battery from the battery holder.
- 3) Place a new lithium battery in the battery holder and connect the battery connector to it.
- 4) Insert the battery holder into the main body.
- 5) Fill in the date for next replacement (5 years after the replacement) on the indication tag using an oil-based pen.

Precautions for Use

- Do not mount the product under the conditions of high temperature and humidity.
- Be sure not to drop the product.
- Be sure to shut down the power (disconnect the wiring between the power supply and the product power terminals) for the wire replacement.
- Before turning on the power, make sure that wires are correctly connected.
- Do not connect wires to vacant terminals.
- Several tens of seconds are required for the product normal operation after the power is turned on. During this time, the ERR1 LED (red) for major alarm lights up temporarily, but this does not indicate an error.
- Leave at least 35 mm clearance between the top/bottom surfaces of the product and other devices.
- Peel off the protective sheet on the top surface of the product before turning on the power. (See Fig. 8.)
- For LONMARK® network variables, see “AB-6824 LONMARK® Functional Profile: Open-Loop Actuator.”

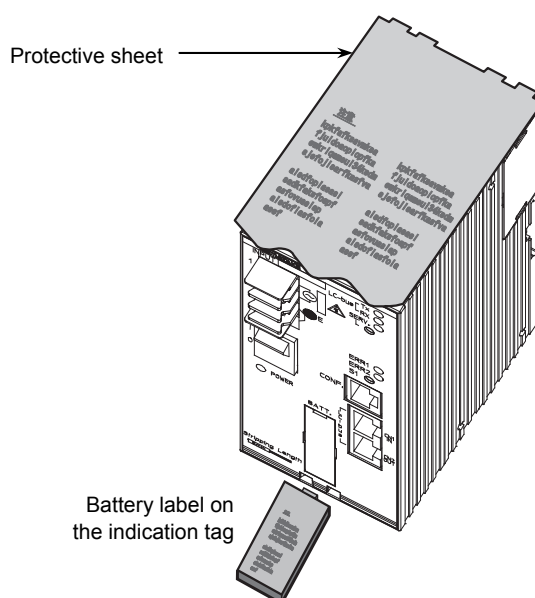

Figure 8. Battery label and protective sheet

azbil

Specifications are subject to change without notice.

Azbil Corporation
Building Systems Company

<http://www.azbil.com/>