

Intelligent Component Series ACTIVAL™ Motorized Two-Way Valve with Flanged-End Connection (JIS 10K / FC200, SCS13A) (Spring Return Type Actuator)

■ General

ACTIVAL™ Models VY516XK and VY616XH are series of motorized two-way valves with flanged-end connection. Rotary valve and actuator are integrated in a single unit.

Valve size ranges from DN15 (1/2") to DN80 (3"), and valve body rating corresponds to JIS 10K.

Actuator has a reversible synchronous motor, which operates at a low voltage of 24 V AC. Since the actuator fully closes the valve in case of power failure, it is suitable for failsafe application.

Model VY516XK/VY516XH communicates with a controller via SAnet (Azbil Corporation's communication protocol).

* Note

JIS: Japanese Industrial Standards



■ Features

- Compact and lightweight:
Rotary valve actualizes small body and light weight.
- Valve and actuator integrated in a single unit:
- SAnet communication:
Intelligent Component Series ACTIVAL communicates with a controller via SAnet, and thus position control signal/position feedback signal is input/output from/to the controller.
- Valves for chilled/hot water control and for steam control applicable to large Cv value, high rangeability, and low leakage.
- Durable actuator with low power consumption.
- Equal percentage flow characteristic.
- Spring return actuator:
Actuator automatically closes the valve in 0 % position in case that the power is down.
- Interlock signal input to fully close the valve:
Interlock input signal to forcibly close the valve in 0 % position is provided.
- Sub-DO for wire saving:
Sub-DO (digital output) provided takes a signal, including a humidifying output of a neighboring device, leading to wire saving.
- CE Marking certified product:
Models VY516XK and VY516XH conform to all the applicable standards of CE Marking.



Safety Instructions

Please read instructions carefully and use the product as specified in this manual. Be sure to keep this manual near by for ready reference.



Usage Restrictions







This product is targeted for general air conditioning. Do not use this product in a situation where human life may be affected. If this product is used in a clean room or a place where reliability or control accuracy is particularly required, please contact Azbil Corporation's sales representative. Azbil Corporation will not bear any responsibility for the results produced by the operators.



Warnings and Cautions















 WARNING	Alerts users that improper handling may cause death or serious injury.
 CAUTION	Alerts users that improper handling may cause minor injury or material loss.

Signs

	Alerts users possible hazardous conditions caused by erroneous operation or erroneous use. The symbol inside \triangle indicates the specific type of danger. (For example, the sign on the left warns of the risk of electric shock.)
	Notifies users that specific actions are prohibited to prevent possible danger. The symbol inside \otimes graphically indicates the prohibited action. (For example, the sign on the left notifies that disassembly is prohibited.)
	Instructs users to carry out a specific obligatory action to prevent possible danger. The symbol inside \bullet graphically indicates the actual action to be carried out. (For example, the sign on the left indicates general instructions.)

 WARNING (1/2)	
	When handling or transporting any heavy product (more than 18 kg), carefully move the product with a hand truck or the like, or with 2 or more people. Careless lifting or accidental dropping of the product may result in injury or product damage.
	Before removing the actuator, fully close the valve. If you try to remove the actuator without fully closing the valve, the actuator may suddenly rotate and cause an injury.
	Before wiring, setting, maintenance, or replacement, be sure to turn off the power to this product. Failure to do so may result in electric shock or device failure.
	Be sure to ground this product with a ground resistance of less than 100 Ω . Improper grounding may cause electric shock or malfunction.
	After wiring, setting, engineering, maintenance, or replacement work, be sure to reattach the cover. Failure to do so may result in electric shock.

 WARNING (2/2)	
	Before setup or engineering work, be sure to turn off power that is supplied from external devices to the output terminals. Failure to do so may cause electric shock.
	Do not disassemble the spring unit. The spring may fly out of the unit and cause an injury.

 CAUTION	
	Provide a circuit protector (e.g., a fuse or circuit breaker) for the power source. Failure to do so may cause a short circuit leading to fire or device failure.
	Do not freeze this product. Doing so may damage the valve body and cause leakage.
	When piping this product, be sure there is no foreign matter in the pipes. If foreign matter remains in the pipes, the product may break down.
	Install, wire, and use this product under the conditions specified by this manual. Failure to do so may cause fire or device failure.
	Use full face gaskets for flat face flanges. Failure to do so may damage the flanges or cause leakage outside of the valve.
	When installing this product, hold it in the proper position and securely fasten it to the pipes. Excessive tightening or improper installation position may damage the valve.
	After installation, make sure no fluid leaks from the valve-pipe connections. Improper piping may cause fluid leakage outside of the valve.
	Do not put a load or weight on this product. Doing so may damage the product.
	Installation and wiring of the actuator must be performed by personnel qualified to do instrumentation and electrical work. Mistakes in installation or wiring may cause fire or electric shock.
	All wiring must comply with applicable codes and ordinances. Otherwise there is a danger of fire.
	Use crimp terminals with insulation for connections to the product terminals. Failure to do so may cause short circuit leading to fire or device failure.
	Tighten the terminal screws with the specified torque. Insufficient tightening of the terminal screws may cause fire or overheating.
	Before setup or engineering work, be sure to turn off power that is supplied from external devices to the output terminals. Failure to do so may cause electric shock.
	Do not carelessly touch this product when it is used to control hot water. Doing so may result in burns, because the product reaches a high temperature.

Trademark information:

ACTIVAL, Inflex, and savic-net are trademarks or registered trademarks of Azbil Corporation in Japan or in other countries. BACnet is a registered trademark of American Society of Heating, Refrigerating and Air-Conditioning Engineers (ASHRAE). KPEV is a registered trademark of Furukawa Electric Co., Ltd.

■ System Configurations

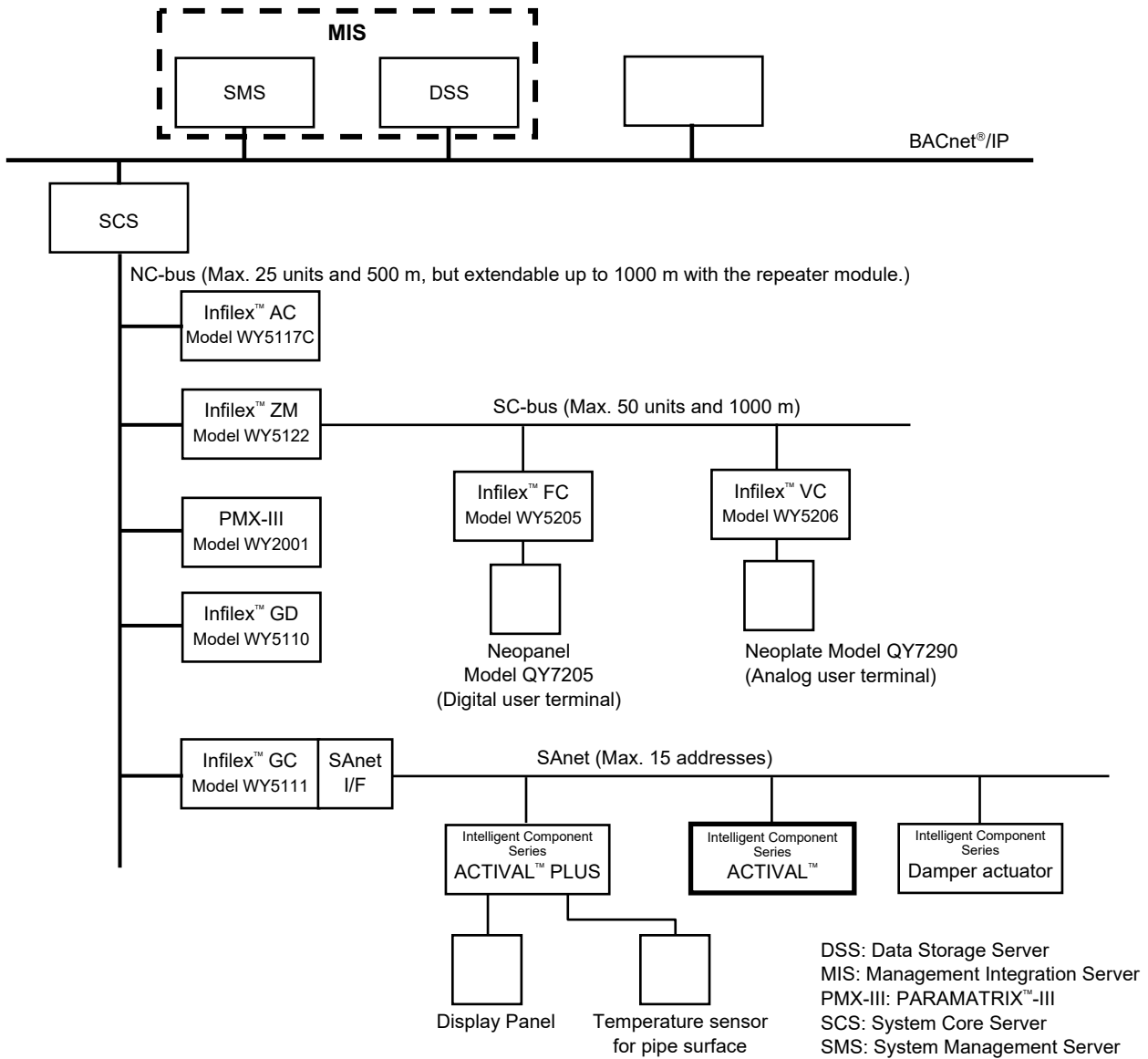

Notes:

- * MIS may be used instead of SMS and DSS for your system. Note that MIS cannot be mixed with SMS or DSS in the same system.
- * Up to two SA-net I/F (interface) module can be connected to one Inflex GC/Inflex GD.
- * For detailed specifications of SA-net, refer to Installation Manual of Intelligent Component Series for SA-net Communication (AB-6713).
- * 1 ACTIVAL or 1 damper actuator requires 1 SA-net address. 1 ACTIVAL PLUS requires 2 SA-net addresses.

Figure 1. System configuration example: SA-net connection in savic-net™ FX system

■ Model Numbers

Models VY516XK00XX and VY516XH00XX are the models for the valve and actuator integrated into a single unit. The model number label is attached to the yoke.

Base model number	Actuator/valve		Actuator		Valve	—	Description
	Control signal	Rating/material	Type	—	Nominal size/Cv		
VY51							Motorized two-way valve with flanged-end connection
	6						SAnet
		5					JIS 10K / JIS FC 200
		6					JIS 10K / JIS SCS13A
			K				IEC IP54 protected, standard torque, and spring return type actuator with terminal block for standard differential pressure application (Mountable valve sizes: DN15 to DN80)
			H				IEC IP54 protected, standard torque, and spring return type actuator with terminal block for high differential pressure application (Mountable valve sizes: DN65 to DN80)
				00			Fixed
					11		DN15 (1/2") / 1.0 in Cv value
					12		DN15 (1/2") / 2.5 in Cv value
					13		DN15 (1/2") / 6.0 in Cv value
					14		DN15 (1/2") / 1.6 in Cv value
					15		DN15 (1/2") / 4.0 in Cv value
					21		DN25 (1") / 10 in Cv value
					22		DN25 (1") / 16 in Cv value
					41		DN40 (1 1/2") / 25 in Cv value
					42		DN40 (1 1/2") / 40 in Cv value
					51		DN50 (2") / 65 in Cv value
					61		DN65 (2 1/2") / 95 in Cv value
					81		DN80 (3") / 125 in Cv value
						-B	Fixed

* Note:

To use DN65 and DN80 models for chilled/hot water or high temperature water control, high differential pressure type (Model VY516XH) is only applicable.

■ Specifications

For weight, refer to the table shown in the section **Dimensions**.

● Valve specifications

Item	Specification				
Type	Two-way valve with flanged-end connection, proportional control				
Body pressure rating	JIS 10K (Max. working pressure: 1.0 MPa)				
Size, Cv, Close-off rating Note: Close-off ratings of the actuator in combination are shown on the right. Practical close-off rating required for the valve controlling 175 °C steam is 0.8 MPa.	Model number	Nominal size	Cv	Close-off ratings	
				Steam	Chilled/hot water High temperature water
	VY516XK0011	DN15 (1/2")	1.0	1.0 MPa	1.0 MPa
	VY516XK0012	DN15 (1/2")	2.5	1.0 MPa	1.0 MPa
	VY516XK0013	DN15 (1/2")	6.0	1.0 MPa	1.0 MPa
	VY516XK0014	DN15 (1/2")	1.6	1.0 MPa	1.0 MPa
	VY516XK0015	DN15 (1/2")	4.0	1.0 MPa	1.0 MPa
	VY516XK0021	DN25 (1")	10	1.0 MPa	1.0 MPa
	VY516XK0022	DN25 (1")	16	1.0 MPa	1.0 MPa
	VY516XK0041	DN40 (1 1/2")	25	1.0 MPa	1.0 MPa
	VY516XK0042	DN40 (1 1/2")	40	1.0 MPa	1.0 MPa
	VY516XK0051	DN50 (2")	65	1.0 MPa	1.0 MPa
	VY516XK0061	DN65 (2 1/2")	95	0.3 MPa	—
	VY516XK0081	DN80 (3")	125	0.1 MPa	—
	VY516XH0061	DN65 (2 1/2")	95	1.0 MPa	0.7 MPa
VY516XH0081	DN80 (3")	125	0.7 MPa	0.4 MPa	
Materials	Body	Gray cast iron (equivalent to JIS FC200) for Model VY5165 Cast stainless steel (equivalent to JIS SCS13A) for Model VY5166			
	Plug, stem	Stainless steel (equivalent to JIS SCS)			
	Seat ring	Heat-resistant PTFE			
	Gland packing	Inorganic fiber			
	Gasket	Non-asbestos joint sheet			
End connection	JIS 10K flanged-end, flat face flange (FF) for Model VY5165 raised face flange (RF) for Model VY5166				
Applicable fluid	Chilled/hot water, high temperature water, steam, brine (ethylene glycol solutions, 50 % max.)				
Allowable fluid temperature	0 °C to 175 °C* (Non-freezing)				
Flow characteristic	Equal percentage				
Rangeability	100 : 1				
Seat leakage	0.01 % of rated Cv value (0.0006 Cv or less for DN15 model)				
Paint	Gray (equivalent to Munsell 5B 4/1): Model VY5165 (Gray cast iron valve body) Unpainted: Model VY5166 (Cast stainless steel valve body)				
Actuator to be combined	Integrated with the valve				

* Note:

To use the stainless steel valve for fluid of temperature below 0 °C, consult with our sales personnel.

● Actuator specifications

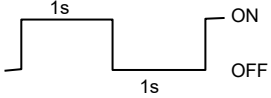
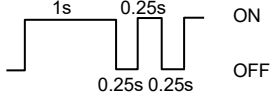
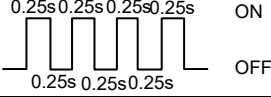
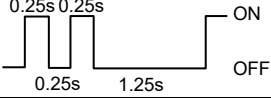
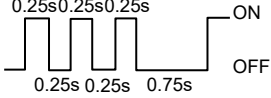
Item		Specification
Power supply		24 V AC \pm 15 %, 50 Hz/60 Hz
Type		Spring return actuator for standard/high differential pressure application
Power consumption		15 VA or less in operating state, 10 VA or less in non-operating state
Timing		63 \pm 5 sec (50 Hz) / 53 \pm 5 sec (60 Hz) Return time: 3 to 40 seconds (fully open \rightarrow fully close operation)
Control signal		SAnet
Forced fully-close input (contact input)	Input type	Potential free (dry) contact input
	Voltage, current	20 V DC, 5 mA (* This contact input is only for interlock operation.)
Sub-DO (contact output)	Output type	Potential free (dry) contact output
	Contact rating	200 V AC/30 V DC, Max. 0.5 A (2 A at startup)
	Min. applicable load	24 V DC, 5 mA
LED indication		Description
Initializing		Continuous ON \rightarrow LED indication corresponding to the operating status (after initializing is complete.)
Normal		Repetition of 1-second ON \rightarrow 1-second OFF. 
Major alarm		Continuous ON.
Minor alarm		Repetition of 1-second ON \rightarrow 0.25-second OFF \rightarrow 0.25-second ON \rightarrow 0.25-second OFF. 
Communication error (and minor alarm)		Repetition of 0.25-second ON \rightarrow 0.25-second OFF 
Manual operation		Repetition of 0.25-second ON \rightarrow 0.25-second OFF \rightarrow 0.25-second ON \rightarrow 1.25-second OFF. 
Error during manual operation		Repetition of 0.25-second ON \rightarrow 0.25-second OFF \rightarrow 0.25-second ON \rightarrow 0.25-second OFF \rightarrow 0.25-second ON \rightarrow 0.75-second OFF. 
Communication (via SAnet)	Transmission system	Voltage transmission (SAnet)
	Transmission speed	1200 bps
	Transmission distance	Transmission distance varies depending on the number of devices and the type of devices to be connected to. For details on the transmission distance, refer to Installation Manual of Intelligent Component Series for SAnet Communication (AB-6713).
Materials	Case	Die cast aluminum
	Top cover, terminal cover	Polycarbonate resin (Color: gray)
	Yoke	Steel plate
	Case and cover of spring unit	Die cast aluminum
	Spring	Stainless steel
Surface finishing	Case	None
	Yoke	Electro-galvanized (Bright chromate finish)
Valve position indication	Pointer located at the bottom of the actuator shows the position by pointing at the value of the scale (0: close to 100: open) on front, rear, and bottom sides.	
Manual operation	Not available.	
Wiring	M3.5 screw terminal connection	
Enclosure protection	IEC IP54 (dust-proof and splash-proof)	
Insulation resistance	Between terminal and case: 5 M Ω or higher at 500 V DC	
Withstand voltage	Between terminal and case: 500 V AC/min with 0.5 mA or less leakage current	
Service life of spring return action	30,000 operations	

● Valve and actuator (as a single unit) specifications

Item		Specification		
Operating conditions		Rated operating condition	Limit operating condition	Transport/storage conditions (packaged*2)
	Ambient temperature*1	-20 °C to 50 °C (Fluid temperature 0 °C to 150 °C)	-20 °C to 60 °C	-20 °C to 70 °C
		-20 °C to 40 °C (Fluid temperature 150 °C to 175 °C)		
	Ambient humidity	5 %RH to 95 %RH		
	Vibration	4.9 m/s ² (10 Hz to 150 Hz)	9.8 m/s ² (10 Hz to 150 Hz)	19.6 m/s ² (10 Hz to 150 Hz)
		Notes: *1 Do not allow the fluid to freeze. *2 Actuator shall be packed during transport.		
Installation location		Indoor / outdoor (Keep away from direct sunlight.) Note: Salt air, corrosive gas, flammable gas, and organic solvent must be avoided.		
Mounting position		Installable in any position ranging from upright to sideways (90° tilted.) * Always install in upright position outdoors.		
Factory preset position		0 % (fully closed) preset at factory.		

● Function

Function	Specification
Data monitoring	Following items can be monitored/operated from the host system (savic-net FX) and Inflex GC/Inflex GD. Valve position setting, valve position measuring, sub-DO output, sub- DI monitoring

* Note:

Above function is available in combination with Inflex GC/Inflex GD and savic-net FX.

● Wire specifications

For details regarding specifications of SAnet communication line (24 V (~), GND (⊥), SAnet), refer to the Installation Manual of SAnet for Intelligent Component Series (AB-6713).

Item	Specification	Length
Contact input (sub-DI)	JIS CVV, JIS VCT, JIS IV, KPEV for low power 0.75 mm ² , 0.9 mm ² , 1.25 mm ² , 2.0 mm ²	30 m
Contact output (sub-DO)	JIS CVV, JIS VCT, JIS IV, KPEV for low power 0.75 mm ² , 0.9 mm ² , 1.25 mm ² , 2.0 mm ²	30 m

Note

* KPEV: Wire standard provided by Furukawa Electric Co., Ltd.

● Options

For options, separate order is required.

Item		Specification	Note	
Seal connector	Part No. 83104346-003	Applicable wire size: ϕ 7 mm to ϕ 9 mm	Seal connector is necessary for IEC IP54 protection.	
	Part No. 83104346-004	Applicable wire size: ϕ 9 mm to ϕ 11 mm		
	Part No. 83104346-005	Applicable wire size: ϕ 11 mm to ϕ 13 mm		
Seal connector for SAnet cable gland	Part No. 83104346-012	Applicable wire size: ϕ 6 mm to ϕ 8 mm	Seal connector for SAnet cable gland with three ports is necessary for IEC IP54 protection.	
	Part No. 83104346-013	Applicable wire size: ϕ 7 mm to ϕ 9 mm		
	Part No. 83104346-014	Applicable wire size: ϕ 9 mm to ϕ 11 mm		
SAnet cable gland with three ports Part No. DY7000A1000	For the specifications of SAnet cable gland with three ports, refer to the Specifications (AS-923E). For the installation of SAnet cable gland with three ports, refer to the Installation Manual of Intelligent Component Series for SAnet Communication (AB-6713).			
Outdoor cover Part No. DY3001A1017	Required when the product is installed outdoors.			
Valve flange adapter kit (for replacing Model V5063/V5064 with Model VY51XX)	Hot-rolled steel (JIS SS4400), electro-galvanized/not electro-galvanized			
		Electro-galvanized	Not electro-galvanized	Applicable valve size
		Part No. 83168456-001	Part No. 83168456-101	DN15
		Part No. 83168456-002	Part No. 83168456-102	DN25
		Part No. 83168456-003	Part No. 83168456-103	DN40
		Part No. 83168456-004	Part No. 83168456-104	DN50
		Part No. 83168456-005	Part No. 83168456-105	DN65
	Part No. 83168456-006	Part No. 83168456-106	DN80	

■ Dimensions

● Model VY5165K00XX

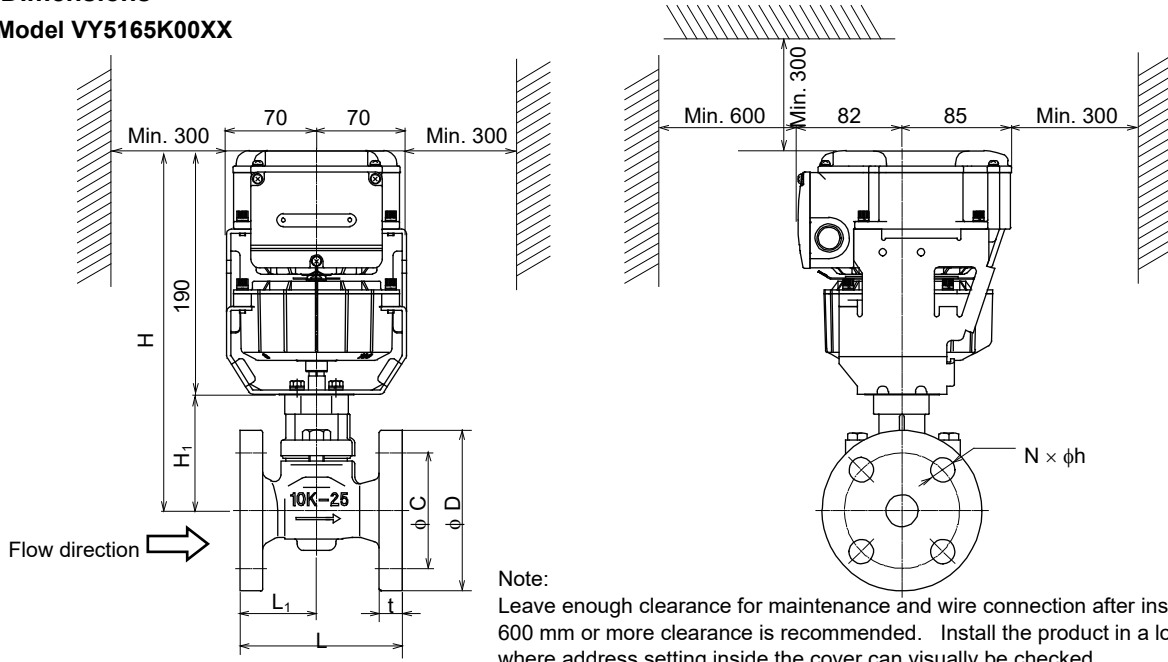

Model number	Valve size (DN)	H (mm)	H ₁ (mm)	L (mm)	L ₁ (mm)	t (mm)	φC (mm)	φD (mm)	φh (mm)	N	Weight (kg)
VY5165K001X	15	265	75	108	50	16	70	95	15	4	6.6
VY5165K002X	25	280	90	127	60	18	90	125	19	4	8.6
VY5165K004X	40	293	103	165	82.5	20	105	140	19	4	12.0
VY5165K0051	50	297	107	178	89	20	120	155	19	4	13.5
VY5165K0061	65	314	124	190	90	22	140	175	19	4	18.0
VY5165K0081	80	315	125	203	100	22	150	185	19	8	20.5

Figure 2. Dimensions and maintenance clearance (mm): Models VY5165K00XX

● Model VY5165H00XX

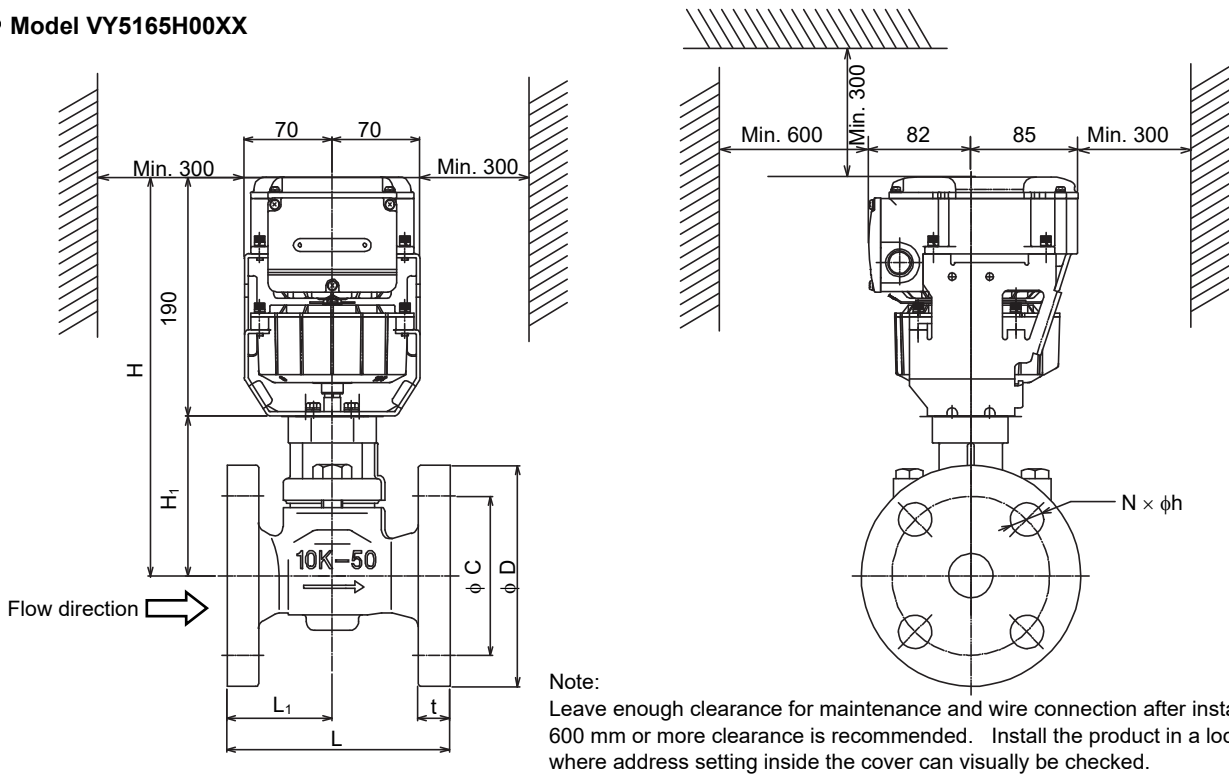

Model number	Valve size (DN)	H (mm)	H ₁ (mm)	L (mm)	L ₁ (mm)	t (mm)	φC (mm)	φD (mm)	φh (mm)	N	Weight (kg)
VY5165H0061	65	314	124	190	90	22	140	175	19	4	18.5
VY5165H0081	80	315	125	203	100	22	150	185	19	8	21.0

Figure 3. Dimensions and maintenance clearance (mm): Models VY5165K00XX

● Model VY5166K00XX

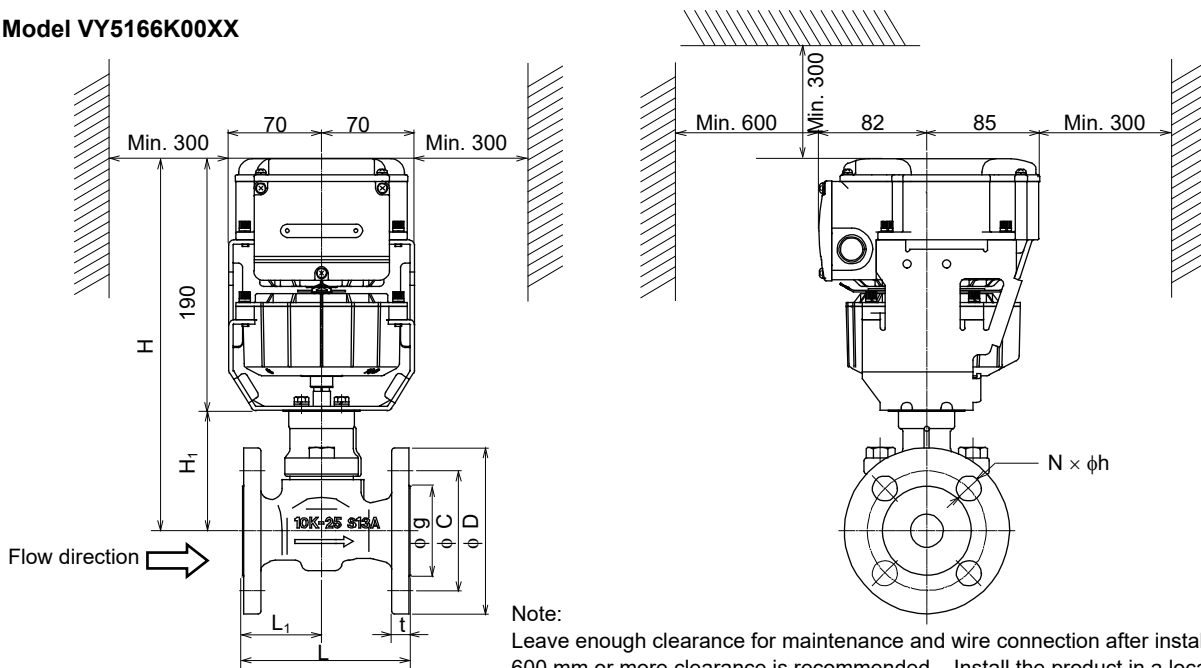

Note:
Leave enough clearance for maintenance and wire connection after installation. 600 mm or more clearance is recommended. Install the product in a location where address setting inside the cover can visually be checked.

Model number	Valve size (DN)	H (mm)	H ₁ (mm)	L (mm)	L ₁ (mm)	t (mm)	ϕC (mm)	ϕD (mm)	ϕg (mm)	ϕh (mm)	N	Weight (kg)
VY5166K001X	15	265	75	108	50	12	70	95	51	15	4	6.6
VY5166K002X	25	280	90	127	60	14	90	125	67	19	4	8.6
VY5166K004X	40	293	103	165	82.5	16	105	140	81	19	4	12.0
VY5166K0051	50	297	107	178	89	16	120	155	96	19	4	13.5
VY5166K0061	65	314	124	190	90	18	140	175	116	19	4	18.0
VY5166K0081	80	315	125	203	100	18	150	185	126	19	8	20.5

Figure 4. Dimensions and maintenance clearance (mm): Model VY5166K00XX

● Model VY5166H00XX

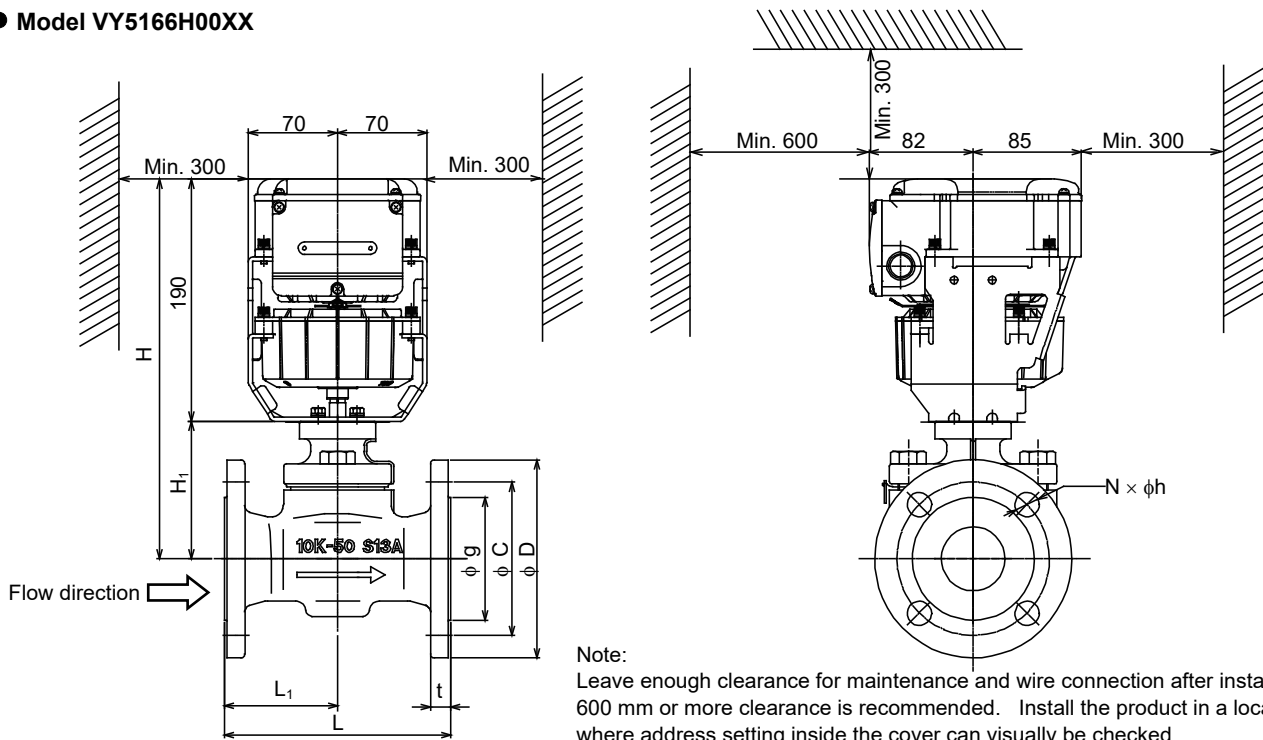

Note:
Leave enough clearance for maintenance and wire connection after installation. 600 mm or more clearance is recommended. Install the product in a location where address setting inside the cover can visually be checked.

Model number	Valve size (DN)	H (mm)	H ₁ (mm)	L (mm)	L ₁ (mm)	t (mm)	ϕC (mm)	ϕD (mm)	ϕg (mm)	ϕh (mm)	N	Weight (kg)
VY5166H0061	65	314	124	190	90	18	140	175	116	19	4	18.5
VY5166H0081	80	315	125	203	100	18	150	185	126	19	8	21.0

Figure 5. Dimensions and maintenance clearance (mm): Models VY5166K, VY5166H

■ Parts Indication

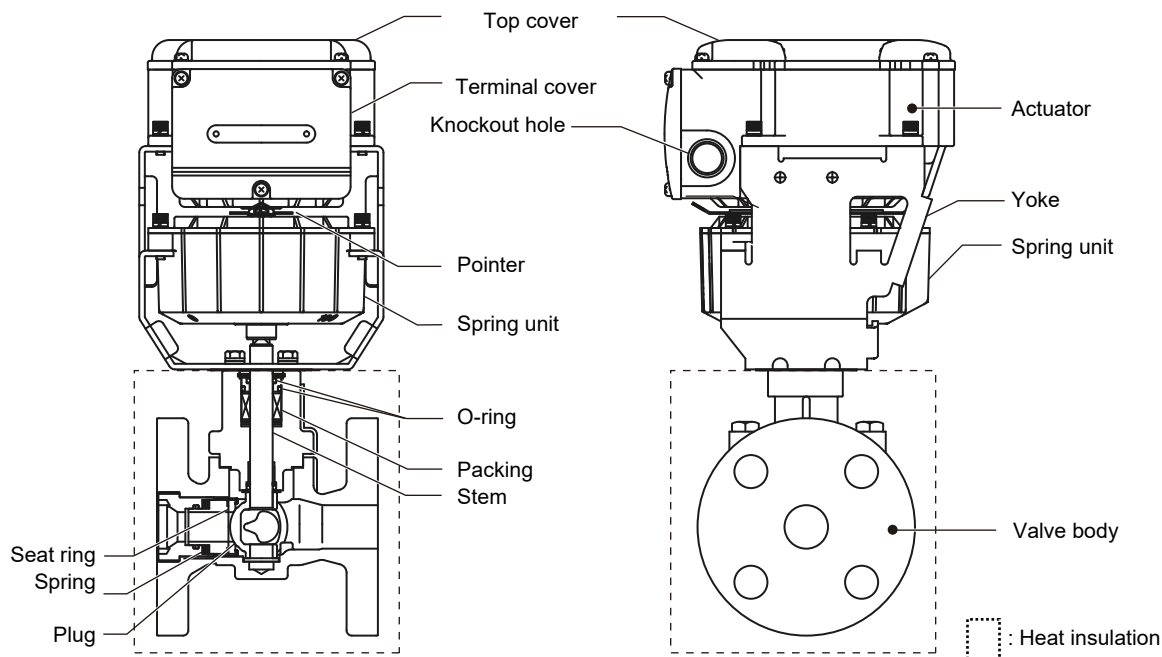

Figure 6. Parts identification

■ Installation

⚠ WARNING	
❗	When handling or transporting any heavy product (more than 18 kg), carefully move the product with a hand truck or the like, or with 2 or more people. Careless lifting or accidental dropping of the product may result in injury or product damage.
❗	Before removing the actuator, fully close the valve. If you try to remove the actuator without fully closing the valve, the actuator may suddenly rotate and cause an injury.
⚠ CAUTION	
⊘	Do not freeze this product. Doing so may damage the valve body and cause leakage.
❗	When piping this product, be sure there is no foreign matter in the pipes. If foreign matter remains in the pipes, the product may break down.
❗	Install, wire, and use this product under the conditions specified by this manual. Failure to do so may cause fire or device failure.
❗	Use full face gaskets for flat face flanges. Failure to do so may damage the flanges or cause leakage outside of the valve.
❗	Installation and wiring of the actuator must be performed by personnel qualified to do instrumentation and electrical work. Mistakes in installation or wiring may cause fire or electric shock.

● Precautions for installation

- ACTIVAL Model VY516XK/VY516XH is the valve and actuator integrated into a single unit. Do not combine the valve with any other actuator, or do not combine the actuator with any other valve.
- To remove foreign substances inside the pipes, install a strainer with 40 or more meshes (with 80 or more meshes recommended for steam control) on the inflow side of each valve. In case that the strainers cannot be installed on the inflow side of each valve, install it on the pipe diverting sections (sections diverting from main piping system to sub piping system).
- Install the valve so that the flow direction of process fluid agrees with the arrow indicated on the valve body.

● **Installation location**

IMPORTANT:

- The top and the terminal covers might be corroded by chemicals and organic solvent or their vapor. Do not expose the ACTIVAL to such substances/vapor.
- When the ACTIVAL is used for steam humidifying, install a valve interlocking with air-conditioning unit on the inflow side in case the ACTIVAL gets damaged.
- Although the ACTIVAL can be used in high humidity environments (max. 95 %RH), do not immerse the actuator in water.
- Although the ACTIVAL can be used outdoors, be sure not to expose the ACTIVAL to direct sunlight.
- When the ACTIVAL is used for steam humidifying, set the high limit alarm of supply air temperature in case that the valve fails to properly operate. For critical piping system, in addition to the high limit alarm of supply air temperature, set the high and low limit alarms of humidity for AHU (air handling unit) operation, and install a valve interlocking with the AHU fan on the inflow side.
- Position the pipes so that drainage does not accumulate next to the valve.
If there is remaining drainage, the valve or pipes may be damaged by steam hammer or corrosion.
Install a trap so that drainage does not accumulate or use a valve made of stainless steel with high erosion and corrosion resistance (JIS SCS13A).

- Install the ACTIVAL in a position allowing easy access for maintenance and inspection. Figs. 2 and 3 show the minimum clearance for maintenance and inspection. When installing the ACTIVAL in a ceiling space, provide an access hole within the 50 cm radius of the ACTIVAL. And, place a drain pan under the valve.
- Do not install the product nearby a steam coil or a hot-water (in high temperature) coil. High heat radiation may result in an actuator malfunction.
- Do not mount the ACTIVAL on a pipe where water hammer occurs, or where solid objects including slug may accumulate.

● **Mounting position**

The ACTIVAL can be mounted in any position ranging from upright to sideways (90° tilted). The ACTIVAL should be installed with its actuator vertically positioned above the valve body. (See Fig. 7.) However, the ACTIVAL must be installed always in upright position outdoors.

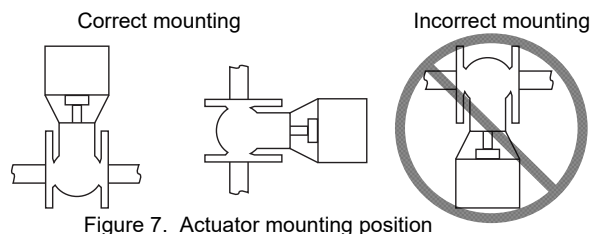

Figure 7. Actuator mounting position

● **Piping**

⚠ CAUTION

! When installing this product, hold it in the proper position and securely fasten it to the pipes. Excessive tightening or improper installation position may damage the valve.

- Check that the model number of the product is what you ordered. The model number is shown on the label attached to the yoke.
- Install a bypass pipe and gate valves on the inflow, outflow, and bypass sides. Also, install a strainer with 40 or more meshes (with 80 or more meshes recommended for steam control) on the inflow side.
- When installing the ACTIVAL to the pipes, do not allow any object, such as chips, to get inside a pipe or valve. Valve cannot fully close, or the valve seat may get damaged causing fluid leakage, due to an object jammed inside the valve.
- When piping, do not apply too much sealing material, such as solidifying liquid and tape, to the pipe connection sections so that these materials flow into the valve. Valve cannot fully closes, or the valve seat may get damaged causing fluid leakage, due to the sealing material jammed inside the valve.
- Before activating the ACTIVAL, fully open the valve (in 100 % position) and flush the pipes (with the ACTIVAL installed) at the maximum flow rate to remove all the foreign substances. (Factory preset position: 0 %)
- For steam control, drain retained water (condensate) in piping. Install a trap on a pipe run which may retain condensate. Condensate may cause water hummer or damage the valve and piping.

⚠ CAUTION	
-----------	--

- | | |
|---|--|
| ⚠ | After installation, make sure no fluid leaks from the valve-pipe connections.
Improper piping may cause fluid leakage outside of the valve. |
| ⊘ | Do not put a load or weight on this product.
Doing so may damage the product. |

● Heat insulation

Do not apply heat insulation to the actuator or to the yoke, as [] shows in Fig. 6. If the yoke and the actuator are covered with insulation material, the pointer cannot be checked and may be distorted.

● Factory preset position

The actuator shaft is positioned at 0 % (in fully closed position) for shipment. The shaft is thus completely turned counterclockwise, and the pointer points at '0'. (See Fig. 8.)

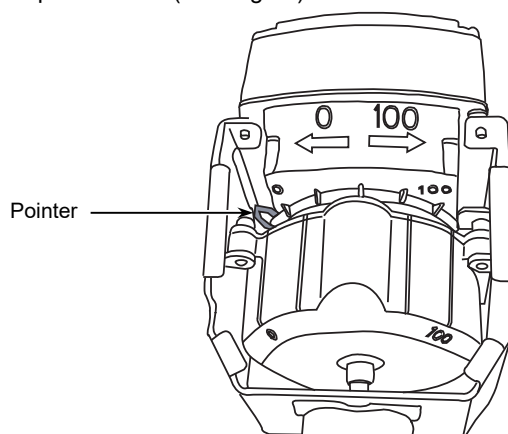

Figure 8. Pointer position for shipment

■ Wiring

⚠ WARNING	
-----------	--

- | | |
|---|--|
| ⚠ | Before wiring, be sure to turn off the power to this product.
Failure to do so may result in electric shock or device failure. |
| ⚡ | Be sure to ground this product with a ground resistance of less than 100 Ω.
Improper grounding may cause electric shock or malfunction. |
| ⚠ | After wiring, be sure to reattach the cover.
Failure to do so may result in electric shock. |

⚠ CAUTION	
-----------	--

- | | |
|---|---|
| ⚠ | Provide a circuit protector (e.g., a fuse or circuit breaker) for the power source.
Failure to do so may cause a short circuit leading to fire or device failure. |
| ⚠ | Install, wire, and use this product under the conditions specified by this manual.
Failure to do so may cause fire or device failure. |
| ⚠ | Installation and wiring of the actuator must be performed by personnel qualified to do instrumentation and electrical work.
Mistakes in installation or wiring may cause fire or electric shock. |
| ⚠ | All wiring must comply with applicable codes and ordinances.
Otherwise there is a danger of fire. |
| ⚠ | Use crimp terminals with insulation for connections to the product terminals.
Failure to do so may cause short circuit leading to fire or device failure. |
| ⚠ | Tighten the terminal screws with the specified torque.
Insufficient tightening of the terminal screws may cause fire or overheating. |

IMPORTANT:

- The ACTIVAL is designed for 24 V AC power supply voltage. Do not apply any other power voltage (e.g., 100 V AC, 200 V AC) to the ACTIVAL.
- To prevent damage, cover the terminals except when connecting/disconnecting wires.

● **Wiring procedure**

- 1) To lead the wires into the terminals, cut out a knockout hole for a wiring port. Two knockout holes (φ22 mm) are provided on the bilateral sides of the actuator terminals. Select a knockout hole according to the conduit mounting direction, and cut it out by lightly knocking the hole using a screwdriver.

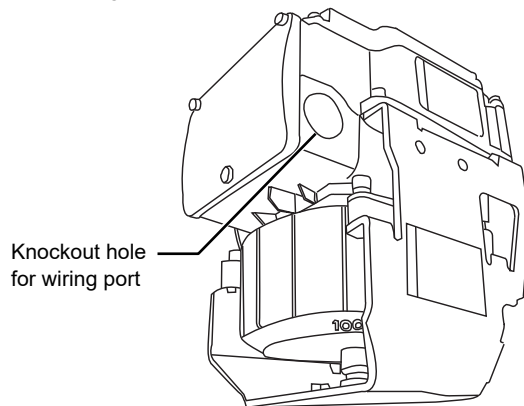

Figure 9. Knockout hole for wiring port

IMPORTANT:

- Do not leave any refuse including metal chips after cutting a knockout hole and after connecting the wires inside the actuator.

- 2) Unscrew the 3 setscrews (M4 × 10) of the terminal cover and remove the terminal cover, as shown in Fig. 10.

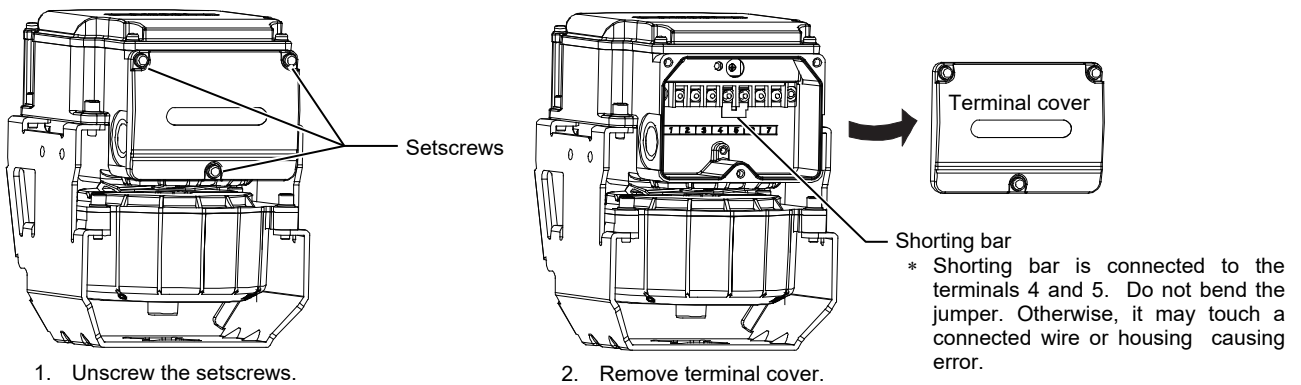

Figure 10. Terminal cover removal

- 3) Correctly connect the wires to the terminals with M3.5 screw terminal lugs, referring to Fig. 11.

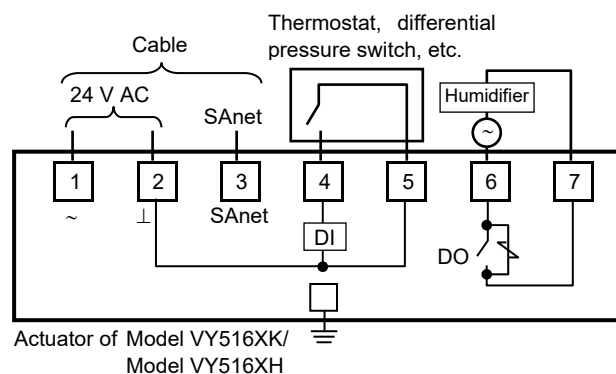

Figure 11. Basic connection example

If 100 V AC or more is output from the sub-DO terminals (6 and 7), be sure to ground with 100 Ω or lower ground resistance. To use the forced shutoff DI, remove the shorting bar connected to the terminals 4 and 5.

- 4) Separate sub-DO line from SAnet and sub-DI lines. Do not lead the sub-DO line through the wiring port (knockout hole) for SAnet and DI lines to protect sub-DO line from noise.

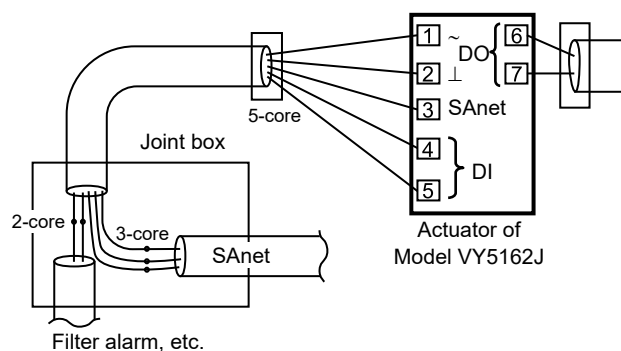

Figure 12. Separation of sub-DO line from other lines

If sub-I/O is used, SAnet line cannot be daisy-chained since the number of the wiring ports is limited. In such a case, use SAnet cable gland with three ports to daisy-chain the SAnet line, or branch the SAnet line ahead of connecting to the terminals.

Note:

For wiring of SAnet line, refer to the Installation Manual of Intelligent Component Series for SAnet Communication (AB-6713)

● To keep IP54 protection (dust-proof and splash-proof),

Use a water-proof connector for the ACTIVAL in a high-humidity environment or outdoor location. Through wiring port with the water-proof connector (Seal connector) attached to, only 1 cable can be lead in. Through wiring port with the SAnet cable gland (with three ports) and the seal connectors attached to, 3 cables can be lead in.

- Be sure to completely close the terminal cover and the top cover.
- Waterproof the wiring port.
 - For cable connection, use a water-proof connector.
(Seal connector Part Nos. 83104346-003, 83104346-004, 83104346-005 are recommended.)
 - To daisy-chain the SAnet line, use the SAnet cable gland with three ports and the seal connector Azbil Corporation supplies.
SAnet cable gland with three ports: Part No. DY7000A1000
Seal connector: Part Nos. 83104346-012, 83104346-013, 83104346-014
 - For conduit connection, use a water-proof plica tube or the like.

Address Setting (Addressing)

⚠ WARNING	
!	Before setup or engineering work, be sure to turn off power that is supplied from external devices to the output terminals. Failure to do so may cause electric shock.

⚠ CAUTION	
⊘	Do not put a load or weight on this product. Doing so may damage the product.
!	Before setup or engineering work, be sure to turn off power that is supplied from external devices to the output terminals. Failure to do so may cause electric shock.
⊘	Do not carelessly touch this product when it is used to control hot water. Doing so may result in burns, because the product reaches a high temperature.

To SAnet interface module, ACTIVAL Model VY516XK/VY516XH and other Intelligent Component Series devices including ACTIVAL PLUS and damper actuators are connected via SAnet. Set address for the terminal devices (Intelligent Component Series devices) so that the SAnet interface module can recognize all the terminal devices connected. Follow the procedure below to set the address. For details regarding address setting (addressing), ask our sales/service personnel.

- 1) Unscrew the setscrews and remove the terminal cover. See Fig. 10 for removing the terminal cover.
- 2) Set address. (See Table 1.) Address can be set with rotary switch, with service pin switch, or based on SAnet ID. Rotary switch and service pin switch are provided on this product. To set the address with rotary switch or based on SAnet ID, Data Setter or PC-MMI is required. Set the address in either way according to your availability.

Setting with rotary switch:

Turn the rotary switch using a precision screwdriver and set.

Setting with service pin switch:

1. Set the rotary switch to '0'.
2. Start addressing operation* of Data Setter or PC-MMI. Then, press the service pin switch. Do not keep the switch pressed for longer than 5 seconds.
3. Address is set within 5 seconds after pressing the service pin switch.

* For the addressing operation of Data Setter or PC-MMI, ask our sales/service personnel.

Setting based on SAnet ID:

1. Set the rotary switch to '0'.
2. With Data Setter or PC-MMI, enter the SAnet ID (on the product code label) and address number to set. The product code label is attached on the side surface of the actuator, as shown in Fig. 12.

* For the addressing operation of Data Setter or PC-MMI, ask our sales/service personnel.

- 3) Attach the terminal cover after setting the address.

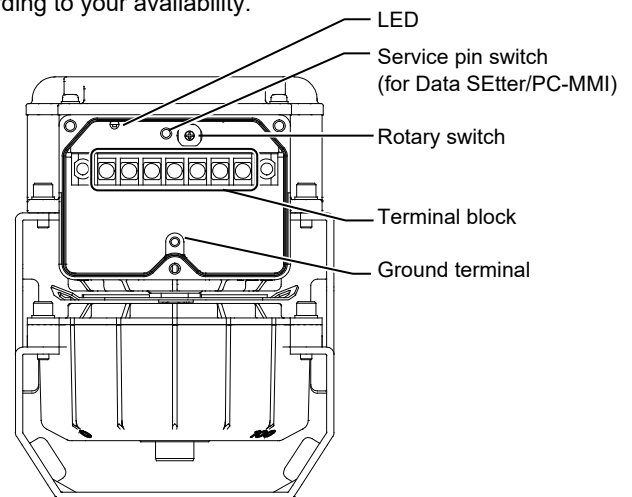

Figure 13. Terminal block, LED, setting switches (without terminal cover)

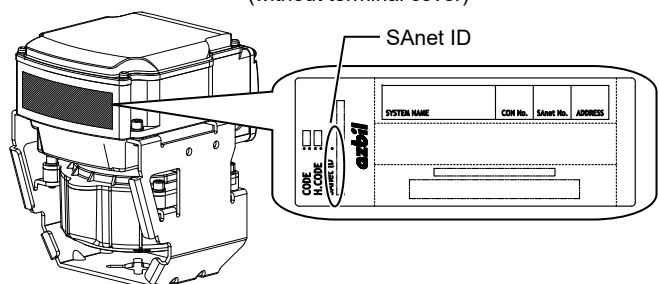

Figure 14. SAnet ID on the product code label

IMPORTANT:	
•	While the terminal cover is removed, do not touch the terminal block or allow anything to touch the terminal block.
•	If the service pin switch is kept pressed for more than 5 seconds, address setting mode will be switched and address will not be set. In such a case, press the service pin switch again and keep it pressed for more than 10 seconds to go back to the normal mode.

Table 1. Basic address setting of this product and other Intelligent Component Series devices

Add.	Device	Sub-DO	Sub-DI
1	Outdoor air damper		
2	Exhaust air damper		
3	Return air damper		
4	Switch damper of total heat exchanger for outdoor air		
5	Switch damper of total heat exchanger for exhaust air		
6	Chilled/hot water valve / Chilled water valve		Filter alarm
7	Hot water valve (Chilled water valve*)	Humidifying ON/OFF	
8	Humidifying valve		Forced fully-close input
D (13)	Reserved		
E (14)	Reserved		
F (15)	Reserved		

Notes:

- * For 'chilled/hot water valve + chilled water valve' application, set address 6 for chilled/hot water valve and 7 for chilled water valve.
- * Items in bold characters are the basic address to set for this product.
- * The above table is a basic setting example. Set address and use sub-I/O in response to system configuration, installation location, and wiring best suitable for your application.
- * Forced shutoff DI is for interlock operation of the spring-return type Model VY516XK, VY516XH. (Not available for the non- spring-return type Model VY516XJ).

■ System Indication Label

A part of the product code label can be a system indication label. Clip the part, and write down the name of the system, host controller number of the system, SAnet line number, and address. Then attach the part, as the system indication label, to a location where you can easily check.

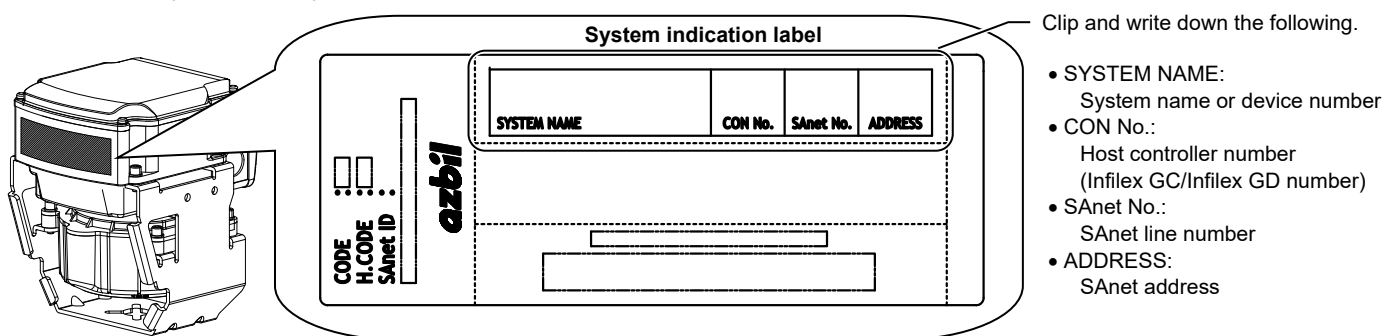

Figure 15. SAnet system indication label

IMPORTANT:

- Attach the system indication label to a clean location with no dust, oil, or moisture.
- Attach the system indication label by pressing the whole surface of the label to stick on the product surface.

⚠ WARNING

- ❗ After setup work, be sure to reattach the cover.
Failure to do so may result in electric shock.
- ❗ Before setup or engineering work, be sure to turn off power that is supplied from external devices to the output terminals. Failure to do so may cause electric shock.

Manual Operation Mode

In the manual operation mode, even when this product has not been connected via SAnet yet, the operations shown in Table 2 can be performed. Follow the procedure below for the operation check. For the locations of the service pin switch and the rotary switch, see Fig. 11.

- 1) Keep the service pin switch pressed for 10 seconds to enter the manual operation mode.
- 2) Turn the rotary switch to the desired position (See Table 2.), using a precision slotted screwdriver.
Operation will start in 3 seconds after setting the rotary switch.

Table 2. Operations in the manual operation mode

Rotary switch scale	Operation
0	Restart (to go back to the normal operation mode)
2	Fully close (in 0 % position)
4	Open in 50 % position
6	Fully open (in 100 % position)
8	Spring return operation check
A	Cancel of spring return operation check
E	Automatic adjustment of the potentiometer.

Notes:

- * Rotary switch scales 1, 3, 5, 7, 8, 9, B to D and F are not available in the manual operation mode.
- * Do not set the rotary switch to 'E'.
(Operation of the rotary switch 'E' is required only when potentiometer itself is replaced.)

- 3) After the operation, press and hold the service pin switch for 10 seconds to go back to the normal operation mode.
- 4) If the address is set with the rotary switch, be sure to reset the rotary switch at the address after entering the normal operation mode.

 **WARNING**

 After engineering work, be sure to reattach the cover.
Failure to do so may result in electric shock.

 Before setup or engineering work, be sure to turn off power that is supplied from external devices to the output terminals. Failure to do so may cause electric shock.

Interlock Operation

This product (Model VY516XK/VY516XH) has the forced shutoff DI (contact input) for interlock operation. Connect the input signal line for start/stop of air-conditioning unit in a critical steam-humidifying system.

Operation with the forced shutoff DI is as follows:

- When the contact opens, the actuator forcibly closes the valve in 0 % position.
- When the contact closes, the actuator continues normal operation.

Jumper is connected to the terminals 4 and 5. Remove the jumper to connect the forced fully-close signal input line. Note that the forced fully-close input is for interlock operation and cannot be used for any other purpose.

● **Interlock operation due to disconnection of SAnet communication**

When SAnet communication is disconnected for a certain time period, this product recognizes abnormal condition and forcibly starts shutoff operation.





Notes:

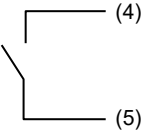
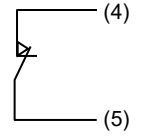

- * Forced shutoff DI is applicable only for Model VY516XK/VY516XH ACTIVAL (spring-return type). This is not applicable for ACTIVAL Model VY516XJ
- * To forcibly shut off the valve, interlock the operation with the forced shutoff DI. Do not interlock with disconnection of SAnet communication.
- * In the manual operation mode, the product does not forcibly start shutoff operation even when SAnet communication is disconnected for a certain time period. But when the forced shutoff contact opens in the manual operation mode, the products forcibly starts the shutoff operation.

Table 3. Interlock operation with the forced shutoff DI

Forced fully-close input * (4) and (5) are terminal numbers	Normal operation mode		Manual peratoin mode mode	
	SAnet communicating	SAnet disconnected (for longer than a certain period)	SAnet communicating	SAnet disconnected (for longer than a certain period)
Contact open 	Forced shutoff	Forced shutoff	Forced shutoff	Forced shutoff
Contact closed 	Normal operation	Normal operation	Normal operation	Normal operation

■ **Maintenance**

 WARNING	
	Before removing the actuator, fully close the valve. If you try to remove the actuator without fully closing the valve, the actuator may suddenly rotate and cause an injury.
	Before doing maintenance, be sure to turn off the power to this product. Failure to do so may result in electric shock or device failure.
	After maintenance, be sure to reattach the cover. Failure to do so may result in electric shock.
	Do not disassemble the spring unit. The spring may fly out of the unit and cause an injury.

 CAUTION	
	Do not put a load or weight on this product. Doing so may damage the product.
	Do not carelessly touch this product when it is used to control hot water. Doing so may result in burns, because the product reaches a high temperature.

- Inspect the ACTIVAL according to Table 4.
- Visually inspect the fluid leakage of the valve and the actuator operations every six months. If any of the problems described in Table 5 are found, take corresponding actions shown in the table.
If your problem is not solved by the corresponding action, please contact Azbil Corporation near you.

Table 4. Inspection items and details

Inspection item	Inspection interval	Inspection detail
Visual inspection	Semiannual	<ul style="list-style-type: none"> • Fluid leakage from the gland and the flange face • Loosened bolts • Valve and actuator damages
Operating status	Semiannual	<ul style="list-style-type: none"> • Unstable open/close operation • Abnormal noise and vibration • Incomplete spring return operation when power is off • Slow spring return operation (taking longer than the rated time (8 to 60 seconds))
Routine inspection	Any time	<ul style="list-style-type: none"> • Fluid leakage to the outside • Abnormal noise and vibration • Unstable open/close operation • Valve hunting

Table 5. Troubleshooting

Problem	Part to check	Action
Fluid leaks from the flange face.	Loosened flange bolts Gasket on the flange face Misaligned piping	Tighten the flange bolts. Replace the gasket. Redo piping.
Fluid leaks from the gland part.	—	Consult with our sales/service personnel.
Fluid leaks from the bonnet.	Loosened bolts	Tighten the bolts.
Valve does not operate smoothly / valve stops halfway / valve does not operate at all.	Conditions of the power applied and of the input signal applied Loosened terminals Wiring condition / disconnected wires	Check the power supply and the controller connected to. Tighten the terminals. Check the wiring.
Fluid leaks to the outside of the valve when the ACTIVAL is in fully closed position.	Actuator pointer not pointing to fully closed position	Fully close the ACTIVAL.
The valve vibrates or produces an abnormal noise.	Primary pressure condition Differential pressure condition	Adjust the mounting position and change the installation location.
Valve hunting occurs.	Secondary pressure condition Differential pressure condition Control stability	Adjust the mounting position and change the installation location. Correct the control parameter setting of controller.
Operating time of the spring return is too short.	Wiring condition of the brake motor	Consult with our sales/service personnel.
Operating time of the spring return is too long. The spring return does not operate.	Torque of valve operation	Consult with our sales/service personnel.
The actuator does not fully closes the valve (in 0 % position).	—	Consult with our sales/service personnel.
SAnet communication error occurs.	—	Consult with our sales/service personnel.

■ Disposal

Dispose of this product as industrial waste in accordance with your local regulations.
Do not reuse all or any part of the product.



This product complies with the following Electromagnetic Compatibility (EMC).
EMC: EN61000-6-2, EN55011 Class A

ACTIVAL and Inflex are trademarks of Azbil Corporation in Japan or in other countries.

Azbil Corporation
Building Systems Company

1-12-2 Kawana, Fujisawa, Kanagawa
251-8522 JAPAN

<https://www.azbil.com/>

Specifications are subject to change without notice.

azbil

AB-6738
Rev. 5.0 Jul. 2020
(J: AI-6738 Rev.7.1)