

Intelligent Component Series Direct Coupled Damper Actuator

General

Model MY8040A direct coupled damper actuator is a motorized actuator to open/close a damper.

Model MY8040A communicates with a controller via SAnet (Azbil Corporation's communication protocol).

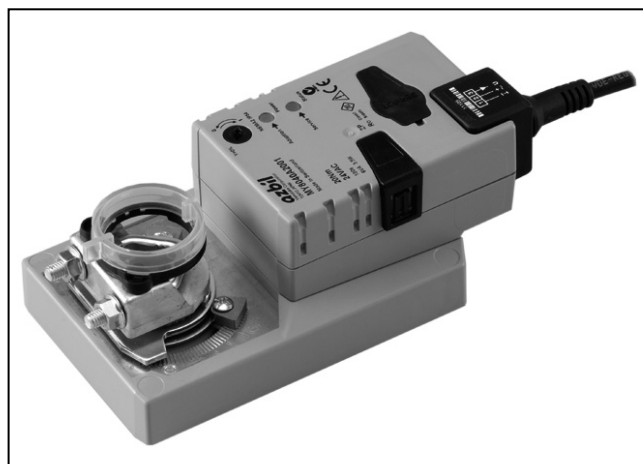

Features

- Intelligent Component Series Model MY8040A communicates with a controller via SAnet, and thus position control signal/position feedback signal is input/output from/to the controller.
- Manual open/close function allows easy adjustment without power supply.
- Torque limit circuit inside the actuator automatically stops the damper in fully closed or open positions.
- Low power consumption allows energy conservation.
- Large torque is assured despite compact, lightweight design.
- Rotary switch on the front surface easily changes the motor rotating direction.
- Simple physical structure facilitates installation on most types of the damper shafts.
- Model MY8040A damper actuator conforms to all the applicable standards of CE Marking.



Safety Instructions

Please read instructions carefully and use the product as specified in this manual. Be sure to keep this manual near by for ready reference.

Usage Restrictions

This product is targeted for general air conditioning. Do not use this product in a situation where human life may be affected. If this product is used in a clean room or a place where reliability or control accuracy is particularly required, please contact Azbil Corporation's sales representative. Azbil Corporation will not bear any responsibility for the results produced by the operators.

 WARNING



- Do not disassemble the product. Disassembly may result in electrical shock or equipment damage.

 CAUTION



- This product must be operated under the operating conditions (power, temperature, humidity, vibration, shock, installation position, atmospheric condition, etc) specified in this manual to prevent equipment damages.



- This product must be operated within its rated operating ranges specified in this manual. Failure to comply will cause equipment damages.



- Operate the product within the service life, and avoid application that keeps product operating cycle excessively frequent. Overuse of the product may cause fire or product damage.



- Installation and wiring must be performed by qualified personnel in accordance with all applicable safety standards.



- Do not install the product in a location with high temperature radiation. High temperature radiation may result in an actuator malfunction.



- Do not put heavy load on the product. It may get damaged.



- All wiring must comply with local codes of indoor wiring and electric installation rules.



- This product does not have a power switch. Be sure to provide a power circuit breaker in the power source.



- To prevent product damage, always disconnect the power supply from the product before performing installation and wiring.



- Make sure all the wires are tightly connected. Incomplete connection may result in an actuator malfunction.



- Do not touch the moving part of the product in operation to prevent personal injury.



- Dispose of this product as an industrial waste in accordance with your local regulations. Do not reuse all or part of this product.

Trademark information:

ACTIVAL, Inflex, and savic-net are trademarks of Azbil Corporation in Japan or in other countries.

BACnet is a registered trademark of American Society of Heating, Refrigerating and Air-Conditioning Engineers (ASHRAE).

System Configurations

Connection example of savic-net™ G5 system

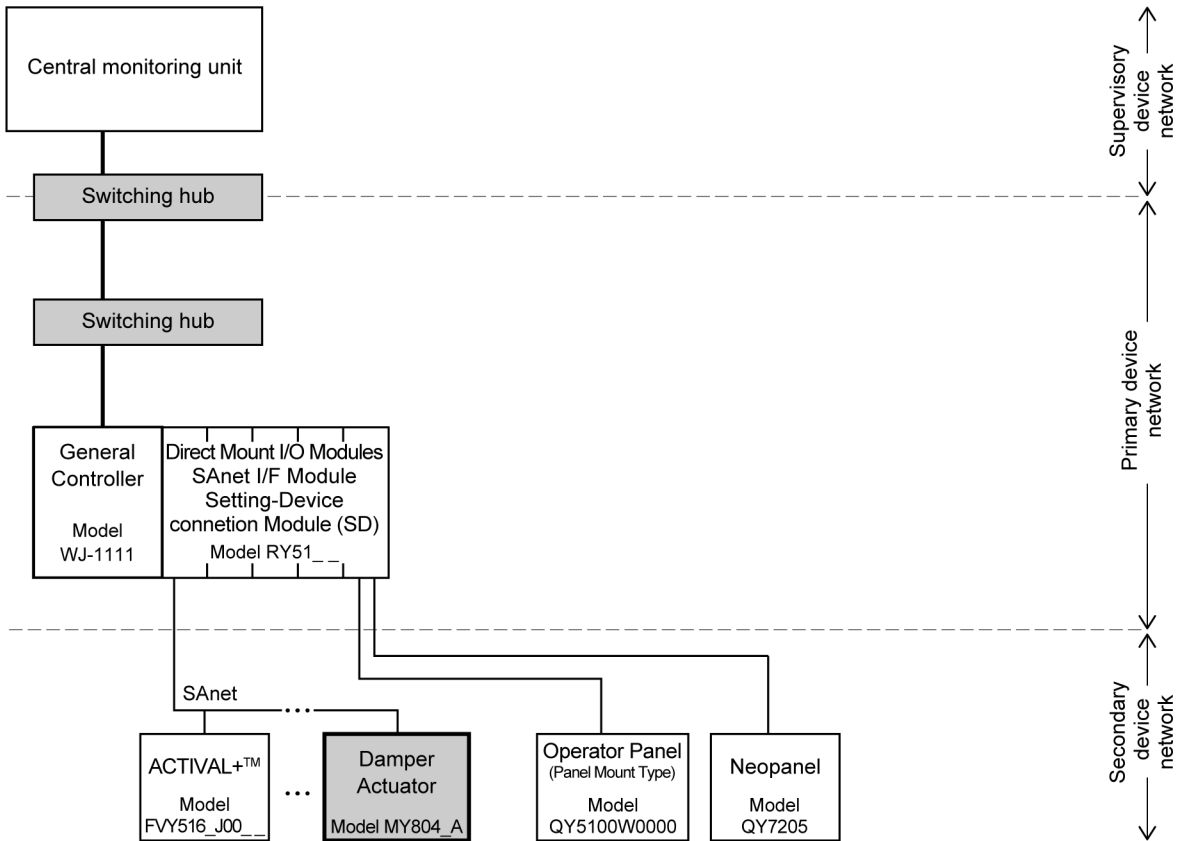

Figure 1. System configuration example: SAnet connection in savic-net™ G5 system

Connection example of savic-net™ FX system

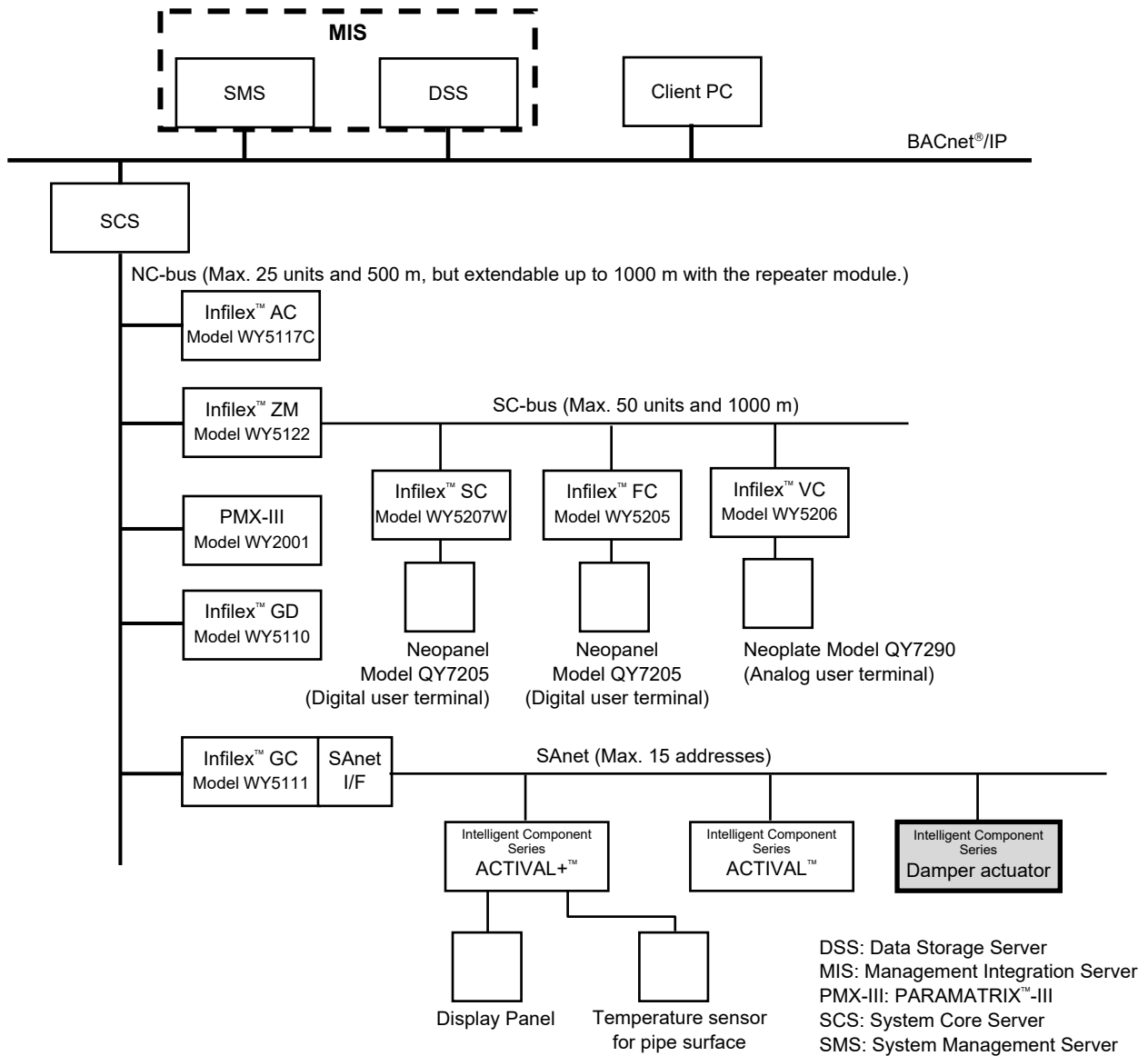

Figure 2. System configuration example: SA-net connection in savic-net™ FX system

Notes:

- * MIS may be used instead of SMS and DSS for your system. Note that MIS cannot be mixed with SMS or DSS in the same system.
- * Up to two SA-net I/F modules can be connected to one General Controller or InflexGC/InflexGD.
- * For detailed specifications of SA-net, refer to Installation Manual of Intelligent Component Series for SA-net Communication (AB-6713).
- * 1 damper actuator or ACTIVAL requires 1 SA-net address. 1 ACTIVAL+ requires 2 SA-net addresses.

Specifications

Item		Specification	
Model number		MY8040A2001	
Power supply voltage		24 V AC \pm 20 %, 50 Hz/60 Hz	
Power consumption		6 VA	
Rotating angle		Max. 95°	
Operating time		Approx. 100 s	
Torque at the rated voltage		20 N·m	
Ambient operating conditions		-20 °C to 50 °C, 95 %RH or less (non-condensing) (This product is not rain-proof and thus is for indoor use only.)	
Transport/storage conditions		-20 °C to 60 °C, 95 %RH or less	
LED indication and switches		Indication	LED operation / switch operation
	Power LED (red) / Adaption switch	Power OFF	LED OFF
		Power ON	LED ON
		To perform Adaption (adjusting rotation angle)	Press the switch.
	Status LED (yellow) / Service pin switch	SAnet off-line	LED OFF
		Adaption (setting rotating angle) or Synchronisation (position alignment) in operation	LED ON
		Addressing (SAnet address setting)	LED blink (repetition of 1.5 second ON-OFF): LED blinks while the address is set and besides, it keeps blinking till the SAnet line links with the controller in on-line mode after the address is set.
SAnet on-line		LED blink (irregularly ON-OFF)	
	To perform Addressing	Press the switch. (After necessary operation of the controller for Addressing, the address is set by pressing the switch.)	
Enclosure rating		IEC IP54 (dust-proof and splash-proof) (Cable conduit must be facing downward.)	
Cable		0.75 mm ² \times 3 cores, 1 m long	
Material / Color		PC-GF10 / Silver gray	
Weight		920 g	
Applicable damper shaft		Circular: ϕ 10 mm to ϕ 20 mm, 42 mm long or longer Square: 10 mm diagonal to 20 mm diagonal, 42 mm long or longer	
Accessories		<ul style="list-style-type: none"> • M4 tapping screws \times 2 • Position indicator ring \times 1 (preassembled with the actuator) • Universal bracket \times 1 (Part No. 12596-0001) • Installation instruction sheet \times 1 	
Insulation resistance		Between case and cable: 100 M Ω or higher at 500 V DC	
Withstand voltage		Between case and cable: 500 V AC for 1 min., 1 mA or less	
Control signal		SAnet	
Communication (via SAnet)	Transmission system	Voltage transmission (SAnet)	
	Transmission speed	1200 bps	
	Transmission distance	Transmission distance varies depending on the number of devices and the type of devices to be connected to. For details on the transmission distance, refer to Installation Manual of Intelligent Component Series for SAnet Communication (AB-6713).	

Function

Function		Specification
Data monitoring*1		Following items can be monitored/operated from the host system (savic-net FX), General Controller (model WJ-1111), and Inflex GC/Inflex GD. Damper position setting, damper position measuring
Damper position adjustment	Adaption (setting of rotation angle)	Rotation angle of the damper is adjusted with PC-MMI, with Data Setter, or with Adaption switch. (Refer to P.8.)
	Synchronisation*2 (position alignment)	Actual damper position and the position of the actuator are matched with PC-MMI, with Data Setter, with Gear release button/Synchronisation switch, or when power is restored from blackout. (Refer to P.8.)

Notes:

*1 Above functions are available in combination with General Controller (model WJ-1111), Inflex GC/Inflex GD, and savic-net FX.

*2 Positions of the actuator and of the damper are matched by fully opening/closing the actuator and the damper. (Default: fully opening)
Synchronisation at the time of power restoration is enabled/disabled by parameter setting. (Default: enabled)

Dimensions

Actuator

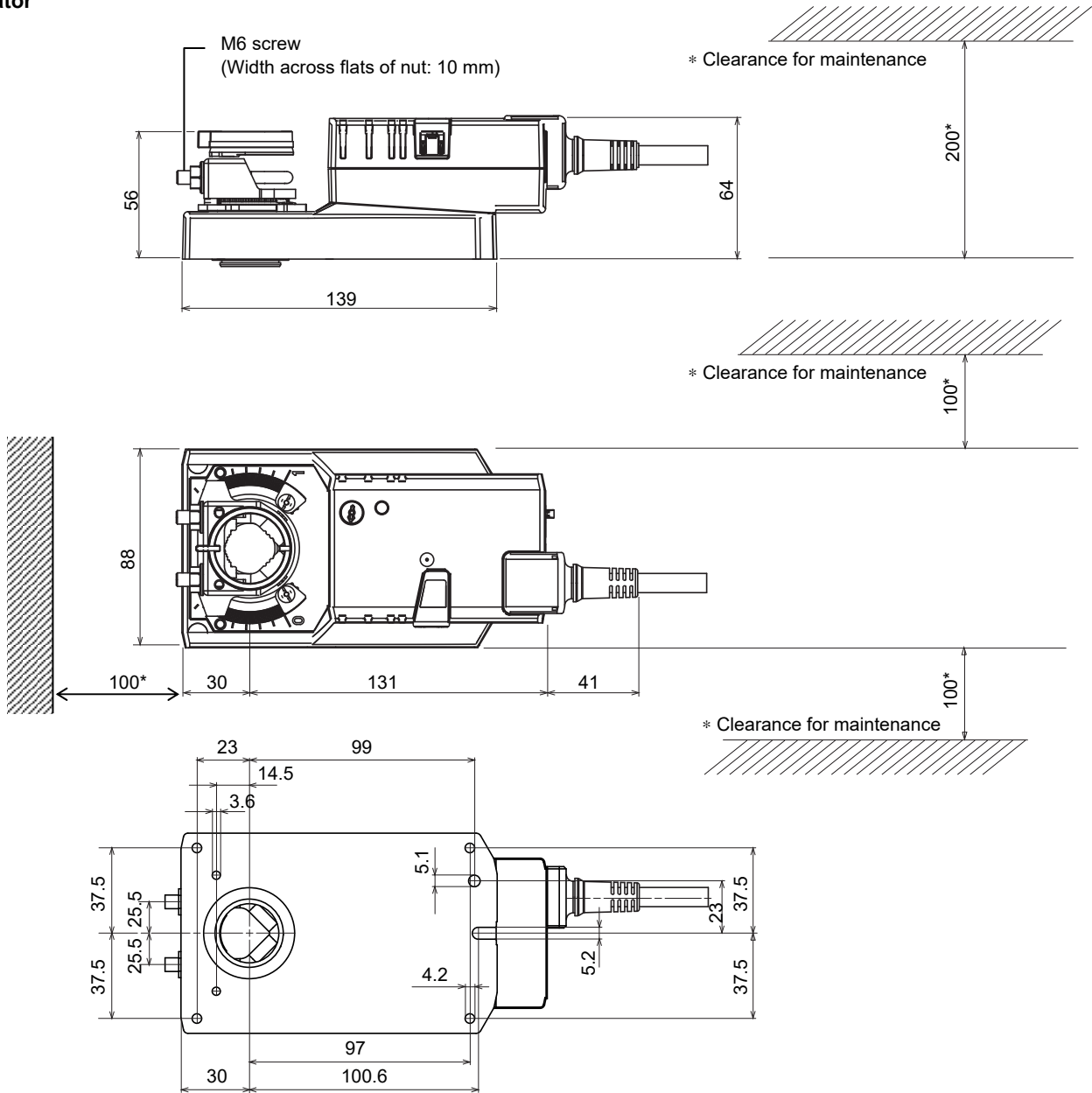

Figure 3. Dimensions (mm): Damper actuator

Universal bracket (Part No. 12596-0001)

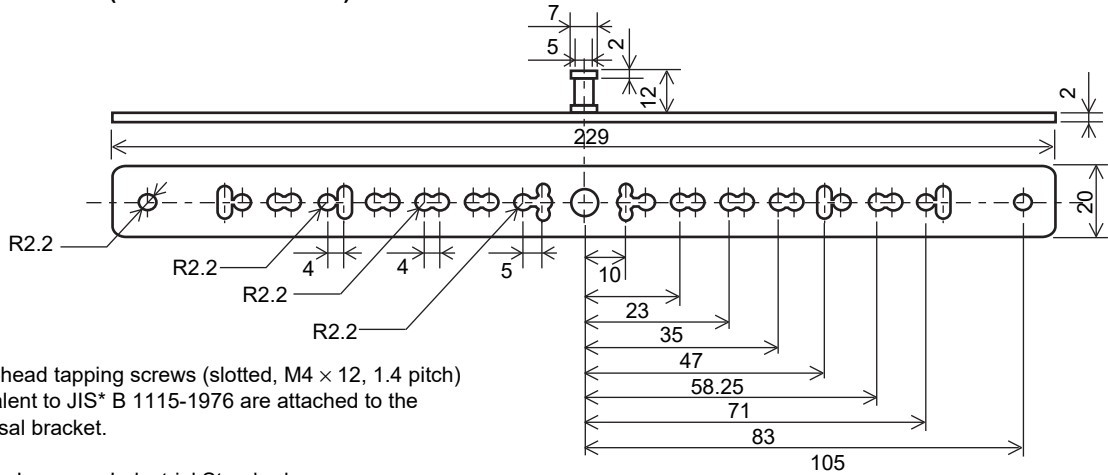
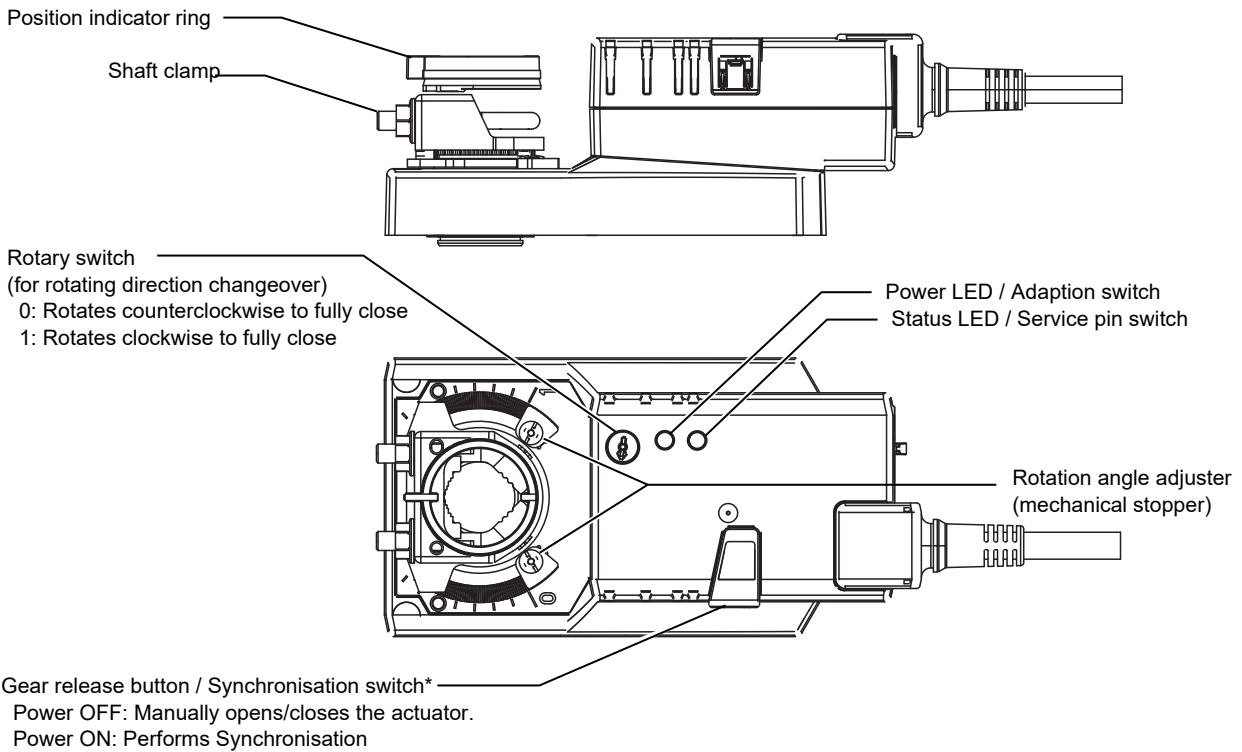

Figure 4. Dimensions (mm): Universal bracket

***Note:**

Universal bracket is supplied with the product. Additionally order only when necessary.

Parts Identification



*** Synchronisation:**

When the gear release button / Synchronisation switch is pressed during power ON, the actuator fully opens/closes the damper regardless of control signal input from the controller. Then, the actuator operates the damper in response to the control signal. The actuator is preset to fully open for Synchronisation. Synchronisation position is switched to fully closed position by parameter setting. Note that Synchronisation is performed by our service personnel. (To our service personnel: Refer to Engineering Manual of Intelligent Component Series for SAnet Communication (AB-6685)).

Figure 5. Parts identification

Installation

 CAUTION
<ul style="list-style-type: none"> To prevent product damage, always disconnect the power supply from the product before performing installation and wiring.

<p>IMPORTANT:</p> <ul style="list-style-type: none"> Avoid application that keeps product operating cycle excessively frequent. Meet the rotating direction of the actuator with the damper rotating direction. Tighten the screws so that the actuator is securely assembled with the damper. When installing this product, leave clearance for maintenance as shown in Fig. 3. Avoid salt damage, corrosive gas, flammable gas, organic solvent atmosphere.

Installation procedure

1) Fully close the damper shaft.

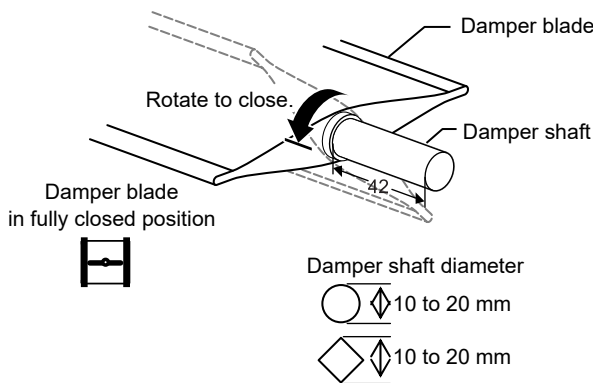

Figure 6. Damper shaft

2) Fully close the actuator (Model MY8040A2001), and mount it to the damper shaft. Finger-tighten the fastening nuts of the shaft clamp to temporarily fix the actuator.

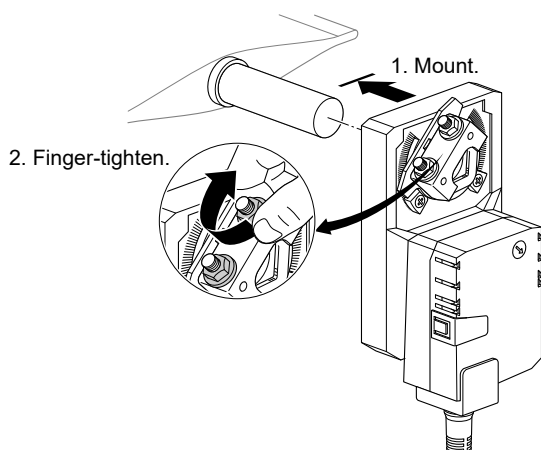

Figure 7. Temporal installation of the actuator body

3) While pressing the gear release button, manually rotate the shaft clamp until it is in the upright position shown in Fig. 8. Then, insert the universal bracket into the slit of the actuator and fix the bracket onto the damper with the two M4 tapping screws.

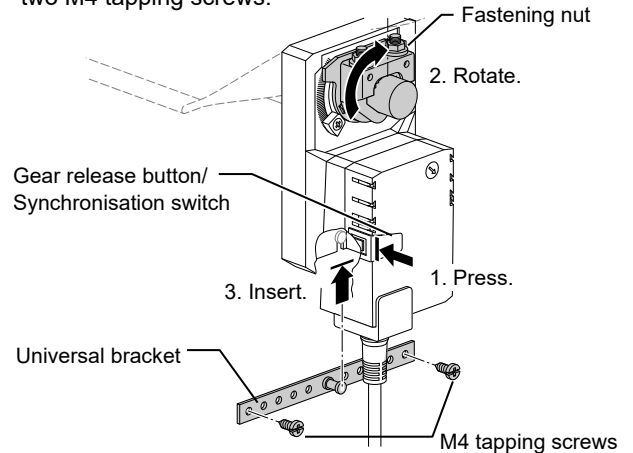

Figure 8. Attaching the universal bracket

4) Manually rotate the shaft clamp back to the fully closed position while pressing the gear release button. At this time, be sure to leave a clearance (approx. 1 mm) between the shaft clamp and the rotation angle adjuster (mechanical stopper). Using a wrench, tighten the fastening nuts of the shaft clamp to completely fix the actuator. Width across flats of the nuts is 10 mm.

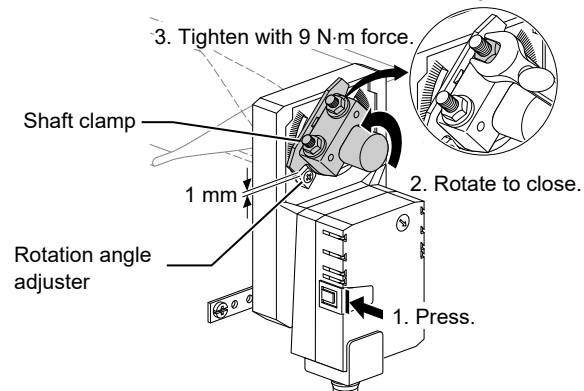

Figure 9. Complete installation of the actuator body

5) Attach the position indicator ring to the damper shaft so that the tip of the damper blade and the pointer of the indicator ring point to the same direction. Adjust the rotation angle adjuster on the fully open side depending on the damper rotating angle.

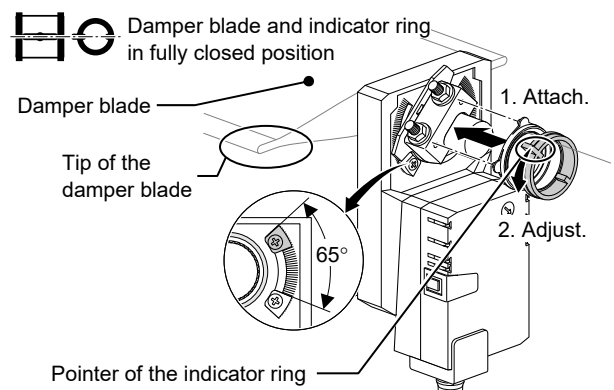



Figure 10. Attaching the position indicator ring

Wiring

 **CAUTION**

- 

 - To prevent product damage, always disconnect the power supply from the product before performing installation and wiring.

Connect the lead wires as follows:

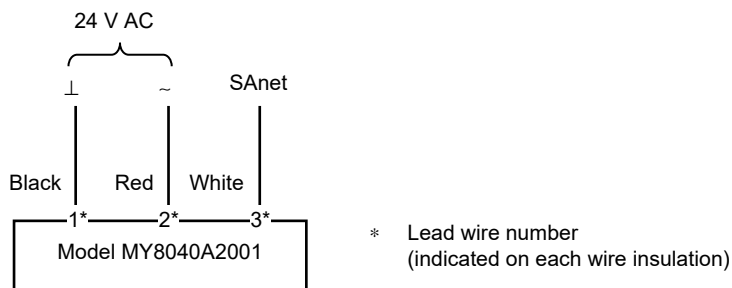

Figure 11. Lead wires connection

For details regarding wires connection, refer to Installation Manual of Intelligent Component Series for SAnet Communication (AB-6713).

Address Setting (Addressing)

To SAnet interface module, the damper actuator Model MY8040A2001 and other Intelligent Component Series devices including ACTIVAL and ACTIVAL+ are connected via SAnet. Set address for the terminal devices (Intelligent Component Series devices) so that the SAnet interface module can recognize all the terminal devices connected. Follow the procedure below to set the address. For details regarding address setting (addressing), ask our sales/service personnel.

Setting with service pin switch:

- 1) Start addressing operation* of Data Setter or PC-MMI. Then, press the service pin switch. Do not keep the switch pressed for longer than 5 seconds.
 - 2) Address is set within 5 seconds after pressing the service pin switch.
- * Communication trouble and duplicated address cause addressing error. Check that address is correctly set in Data Setter or PC-MMI.

Setting based on SAnet ID:

With Data Setter or PC-MMI, enter the SAnet ID (on the SAnet ID label) and address number to set. The SAnet ID label is attached on a side surface of the actuator, as shown in Fig. 12.

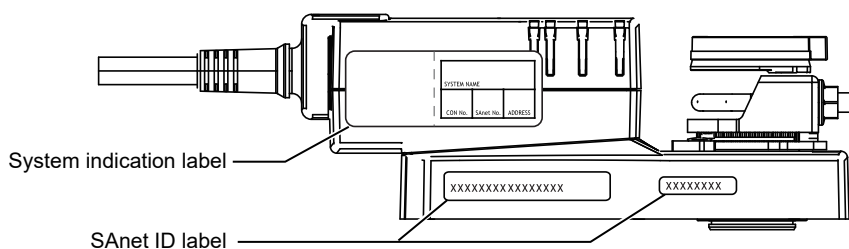

Figure 12. Locations of the labels

IMPORTANT:

- Address setting must be performed by our service personnel or qualified expert.

Table 1. Basic address setting of this product and other Intelligent Component Series devices

Address.	Device	Sub-DO	Sub-DI
1	Outdoor air damper		
2	Exhaust air damper		
3	Return air damper		
4	Switch damper of total heat exchanger for outdoor air		
5	Switch damper of total heat exchanger for exhaust air		
6	Chilled/hot water valve / Chilled water valve		Filter alarm
7	Hot water valve (Chilled water valve*)	Humidifying ON/OFF	
8	Humidifying valve		
9	Reserved		
A (10)	Reserved		
B (11)	Reserved		
C (12)	Reserved		
D (13)	Reserved		
E (14)	Reserved		
F (15)	Reserved		

Notes:

- *1. For 'chilled/hot water valve + chilled water valve' application, set 6 for chilled/hot water valve and 7 for chilled water valve.
- *2. Items in bold characters are the basic address to set for this product.
- *3. The above table is a basic setting example. Set address and use auxiliary I/O in response to system configuration, installation location, wiring.

System Indication Label

SAnet system indication label is attached to the side surface of the product. Clip the label and write down the name of the SAnet system, host controller number of the SAnet system, SAnet line number, and address. Then attach the SAnet system indication label to a location where you can easily check.

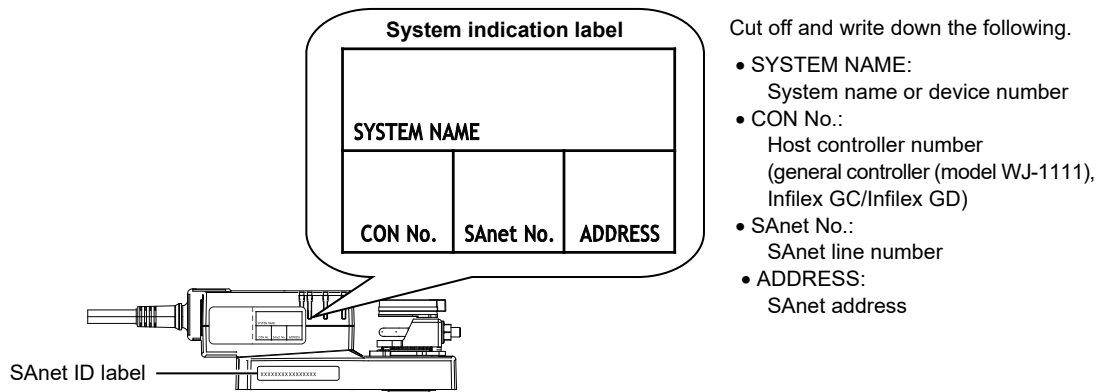

Figure 13. SAnet system indication label

IMPORTANT:

- Attach the system indication label to a clean location with no dust, oil, or moisture.
- Attach the system indication label by pressing the whole surface of the label to stick on the product surface.

Adaption (Setting Rotating Angle)

When the rotation angle of the actuator is adjusted or changed, the actuator needs to memorize (adapt) the adjusted/changed rotation angle. Note that Adaption is performed by our service personnel.

(To our service personnel: Refer to Engineering Manual of Intelligent Component Series for SAnet Communication (AB-6685))

Synchronisation (Position Alignment)

Damper position which the actuator controls disagrees with the actual damper position if actuator mounting position on the shaft is changed. In such a case, the actuator requires Synchronisation so that the damper position controlled by the actuator and the actual damper position agree (synchronize). Note that Synchronisation is performed by our service personnel.

(To our service personnel: Refer to Engineering Manual of Intelligent Component Series for SAnet Communication (AB-6685).)

azbil

Specifications are subject to change without notice.

Azbil Corporation

Building Systems Company

1-12-2 Kawana, Fujisawa, Kanagawa
251-8522 JAPAN

<https://www.azbil.com/>