

ACTIVAL™

Motorized Two-Way Valve with Flanged-End Connection for High Differential Pressure Application (JIS 10K-FC200, SCS13A)

Overview

ACTIVAL Model VY51__J is a series of motorized two-way rotary valves, DN15 to DN150, with flanged-end connection. The valve and actuator are integrated in a single unit.

The valve body rating corresponds to JIS 10K.

The actuator has a reversible synchronous motor, which operates at a low voltage of 24 V AC.

There are following four control signals available.

- Nominal 135 Ω feedback potentiometer
Provides proportional control in combination with a DDC controller. (e.g., Inflex GC Model WY5111)
- Nominal resistance 135 Ω input
Provides proportional control in combination with a proportionally controlled electric controller. (e.g., Neostat Model TY900_Z, insertion type Thermostat Model TY9800)
- 4-20 mA DC input
Provides proportional control in combination with a DDC controller. (e.g., Inflex GC Model WY5111, Model R35/R36)
- 2-10 V DC input
Provides proportional control in combination with a DDC controller. (e.g., Inflex AC Model WY5117)

Features

- Applicable for the high differential pressure applications such as controlling the bypass valve. Water flow is controlled inside the valve to prevent over pressure drop, leading to cavitation erosion resistance.

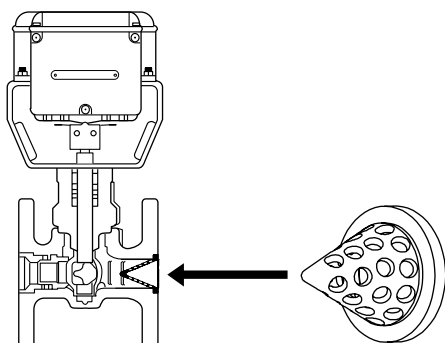
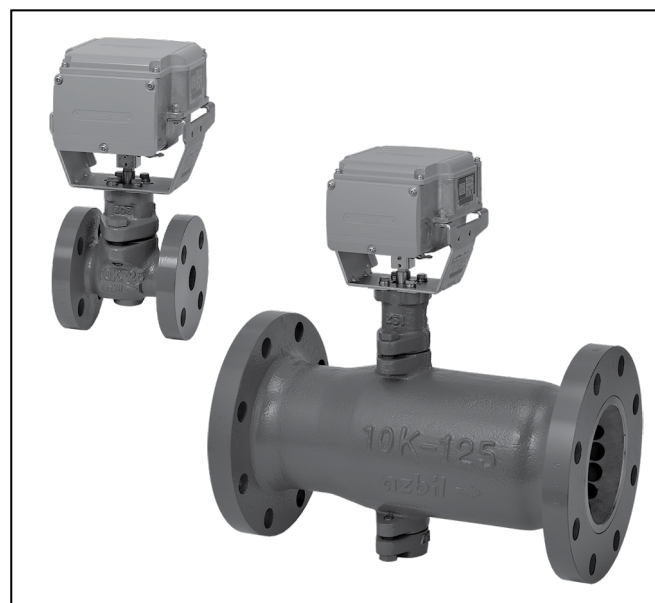

Figure 1 Mechanism of cavitation erosion resistance



Note: Pictures of DN25 and DN125 are posted.

The shape differs depending on the valve size.

Notes:

- AHU: Air Handling Unit
- DDC: Direct Digital Control
- JIS: Japanese Industrial Standards

- Compact and lightweight
- Valve and actuator integrated in a single unit
- Conforms to IP54 (dust-proof, splash-proof)
Can be installed in AHU.
Note: Waterproof connectors are required to assure IP54.
- A variety of control input signals available
- Durable actuator with low power consumption
- 2–10 V DC output with feedback signal
Only for 4-20 mA DC input type (Model VY513_) and 2–10 V DC input type (Model VY514_)
- Modified linear flow characteristics
- Valve is applicable for high differential pressure, large Cv value, high rangeability, and low leakage.

IMPORTANT

- If you want to use this product combined with a third party's controller, please contact Azbil corporation.

Safety Precautions

Please read instructions carefully and use the product as specified in this manual. Be sure to keep this manual nearby for quick reference.

Restrictions on Use

This product was developed, designed, and manufactured for general air conditioning use.

Do not use the product in a situation where human life may be at risk or for nuclear applications in radiation controlled areas. If you wish to use the product in a radiation controlled area, please contact Azbil Corporation.

Particularly when the product is used in the following applications where safety is required, implementation of fail-safe design, redundant design, regular maintenance, etc., should be considered in order to use the product safely and reliably.

- Safety devices for protecting the human body
- Start/stop control devices for transportation machines
- Aeronautical/aerospace machines

For system design, application design, instructions for use, or product applications, please contact Azbil Corporation.

Azbil Corporation bears no responsibility for any result, or lack of result, deriving from the customer's use of the product.

Recommended Design Life

It is recommended that this product be used within the recommended design life.

The recommended design life is the period during which you can use the product safely and reliably based on the design specifications.

If the product is used beyond this period, its failure ratio may increase due to time-related deterioration of parts, etc.



The recommended design life during which the product can operate reliably with the lowest failure ratio and least deterioration over time is estimated scientifically based on acceleration tests, endurance tests, etc., taking into consideration the operating environment, conditions, and frequency of use as basic parameters.

The recommended design life of this product is 10 years.





The recommended design life assumes that maintenance, such as replacement of the limited life parts, is carried out properly.



Refer to the section on maintenance in this manual.







Warnings and Cautions

	WARNING Alerts users that improper handling may cause death or serious injury.
	CAUTION Alerts users that improper handling may cause minor injury or material loss.

Signs

	Notifies users that specific actions are prohibited to prevent possible danger. The symbol inside  graphically indicates the prohibited action. (For example, the sign on the left means that disassembly is prohibited.)
	Instructs users to carry out a specific obligatory action to prevent possible danger. The symbol inside  graphically indicates the actual action to be carried out. (For example, the sign on the left indicates general instructions.)

 WARNING	
	When handling or transporting any heavy product (more than 18 kg), carefully move the product with a handtruck or the like, or with 2 or more people. Careless lifting or accidental dropping of the product may result in injury or product damage.

 CAUTION	
	Provide a circuit protector (e.g., a fuse or circuit breaker) for the power source. Failure to do so may cause a short circuit leading to fire or device failure.
	Do not freeze this product. Doing so may damage the valve body and cause leakage.
	When piping this product, be sure there is no foreign matter in the pipes. If foreign matter remains in the pipes, the product may break down.
	Install, wire, and use this product under the conditions specified by this manual. Failure to do so may cause fire or device failure.
	Use full face gaskets for flat face flanges. Failure to do so may damage the flanges or cause leakage outside of the valve.
	When installing this product, hold it in the proper position and securely fasten it to the pipes. Excessive tightening or improper installation position may damage the valve.

⚠ CAUTION	
❗	After installation, make sure no fluid leaks from the valve-pipe connections. Improper piping may cause fluid leakage outside of the valve.
⊘	Do not put a load or weight on this product. Doing so may damage the product.
❗	Installation and wiring of the actuator must be performed by personnel qualified to do instrumentation and electrical work. Mistakes in installation or wiring may cause fire or electric shock.
❗	Before wiring or maintenance, be sure to turn off the power to this product. Failure to do so may result in electric shock or device failure.
❗	All wiring must comply with applicable codes and ordinances. Otherwise there is a danger of fire.

⚠ CAUTION	
❗	Use crimp terminals with insulation for connections to the product terminals. Failure to do so may cause short circuit leading to fire or device failure.
❗	Tighten the terminal screws with the specified torque. Insufficient tightening of the terminal screws may cause fire or overheating.
❗	After wiring or maintenance, be sure to reattach the terminal cover. Failure to do so may result in electric shock.
⊘	Do not carelessly touch this product when it is used to control hot water. Doing so may result in burns, because the product reaches a high temperature.

■ Model Numbers

Model VY51__J0__ is the model for the valve and actuator integrated into a single unit.

The model number label is attached on the yoke.

Base model number	Actuator/valve		Actuator		Valve	Description
	Control signal	Rating/material	Type	Fixed	Valve size Cv	
VY51						Motorized two-way rotary valve
	1					Nominal 135 Ω feedback potentiometer (F motor type)
	2					Nominal 135 Ω resistance input (E motor type)
	3					4–20 mA DC with 2–10 V DC feedback signal
	4					2–10 V DC input with 2–10 V DC feedback signal
		3				JIS 10K-FC200 (for chilled/hot water) with cavitation erosion resistant mechanism
		4				JIS 10K-SCS13A (for chilled/hot water) with cavitation erosion resistant mechanism
			J			IEC IP54 (dust-proof, splash-proof), with standard torque type terminal block (Applicable valve sizes: DN15 to DN 125)
						IEC IP54 (dust-proof, splash-proof), with high voltage type terminal block (Applicable valve size: DN150)
				0		Fixed
					012	DN15 (1/2"), Cv: 2.5
					020	DN25 (1"), Cv: 6.8
					021	DN25 (1"), Cv: 10
					040	DN40 (1½"), Cv: 16
					041	DN40 (1½"), Cv: 25
					050	DN50 (2"), Cv: 40
					060	DN65 (2½"), Cv: 65
					080	DN80 (3"), Cv: 95
					101*	DN100 (4"), Cv: 180
					121*	DN125 (5"), Cv: 234
					151*	DN150 (6"), Cv: 350

Note:
- IEC: International Electrotechnical Commission

* When JIS 10K-FC200 (Model VY51_3) is selected according to the rating and material of the valve, 101, 121, or 151 can be selected by specifying the valve size and Cv.

● Options

Item	Model number		Specification			
Power transformer	AT72-J1		Primary voltage	100 V AC, 200 V AC, or 220 V AC		
			Secondary voltage	23 V AC		
			Power frequency	50–60 Hz		
Waterproof connector*1	83104346-	003	Applicable wire	Dia. 7–9 mm		
Auxiliary switch*2	83174063-	101	Number of auxiliary switches	2		
			Max. applied voltage, current	30 V DC, 100 mA*3 (Inductive load includes inrush current.)		
			Operation range	SWA: variable from 0 % (fully closed) to 100 % (fully open)		
				SWB: variable from 0 % (fully closed) to 100 % (fully open)		
Auxiliary potentiometer*2	83165275-	001	Number of auxiliary potentiometers	1		
			Total resistance	Nominal 1 kΩ		
			Operation range	0 % (fully closed) to 100 % (fully open)		
			Max. applied voltage	5 V DC Note: It cannot be connected with Model M904E.		
Valve flange adapter kit*4	83168456-	001	Applicable valve size	Major materials		
			002	DN15	Hot rolled steel (SS400)	Galvanized
			003	DN25		
			004	DN40		
			005	DN50		
			006	DN65		
			006	DN80		
			101	DN15	Non-galvanized	
			102	DN25		
			103	DN40		
			104	DN50		
			105	DN65		
			106	DN80		
106	DN80					
Outdoor cover	DY3001A1017		Material	Stainless steel plate t1.0		
			Weight	Approx. 550 g		

*1 Required to maintain IP54.

*2 Either the auxiliary switch or the auxiliary potentiometer can be added. Cannot coexist. For details, refer to the user's manual attached to the product.

*3 If the applied current exceeds 100 mA, please contact Azbil Corporation.

*4 It is for replacing Model V5063 or Model V5064 with Model VY51__.

■ Specifications

● Valve and actuator

Item	Specification		
Operating conditions	Rated operating conditions	Ambient temperature	-20–50 °C (when temperature of fluid is 0–150 °C) -20–40 °C (when temperature of fluid is 150–175 °C)
		Ambient humidity	5–95 % RH
		Vibration	4.9 m/s ² (10–150 Hz)
	Transportation/storage conditions (in packed state)	Ambient temperature	-20–70 °C
		Ambient humidity	5–95 % RH
		Vibration	19.6 m/s ² (10–150 Hz)
Installation location	Indoor use Note: Salt air, corrosive gas, flammable gas, and organic solvent must be avoided.		
	Outdoor use Note: Salt air, corrosive gas, flammable gas, and organic solvent must be avoided. And, use the outdoor cover (to be ordered separately) etc. to avoid direct sunlight.		
Mounting position	Refer to ■ "Installation," • "Mounting position."		
Manual operation	Available Refer to ■ "Installation," • "Manual open/close operation."		
Insulation resistance	Between terminals and case	5 MΩ or more at 500 V DC	
Withstand voltage	Between terminals and case	500 V AC / 1 min with leak current 5 mA or less	
Weight	Model VY51__ J0	012	4.6 kg
		020	6.6 kg
		021	
		040	10 kg
		041	
		050	11.5 kg
		060	16.0 kg
		080	18.5 kg
		101	37 kg
		121	
	151	49 kg	

● Valve

Item	Specification				
Type of valve	Two-way valve, flanged-end connection				
Rated pressure	JIS 10K (max. operating pressure 1.0 MPa)				
Valve size, Cv, Closed-off rating	Model		Valve size	Cv	Closed-off rating
	VY51__J0	012	DN15 (1/2")	2.5	
		020	DN25 (1")	6.8	
		021	DN25 (1")	10.0	
		040	DN40 (1½")	16	
		041	DN40 (1½")	25	
		050	DN50 (2")	40	
		060	DN65 (2½")	65	
		080	DN80 (3")	95	
		101	DN100 (4")	180	0.5 MPa
	121	DN125 (5")	234		
	151	DN150 (6")	350	0.5 MPa*	
End connection	Flanged-end connection (JIS 10K) Flat face flange (FF) : body cast iron (FC200) Raised face flange (RF) : body stainless steel (SCS13A)				
Applicable fluid	Chilled/hot water, high temperature water, brine (glycol concentration: 50 % or less)				
Temperature of fluid	For valve size DN15 to DN80	0–175 °C			
	For valve size DN100 to DN150	0–130 °C			
Flow characteristics	Modified linear characteristic				
Rangeability	100:1				
Leakage from valve seat	0.01 % of the rated Cv (max. 0.0006 of Cv for DN15)				
Major materials	Body	Model VY51_3	Cast iron (FC200)		
		Model VY51_4	Stainless steel (SCS13A)		
	Plug, stem		Stainless steel (equivalent to SCS13A)		
	Cone	Size DN15 to DN80	Stainless steel (SCS13A)		
		Size DN100 to DN150	Cast iron (SCPH2)		
	Seat ring		Heat-resistant PTFE		
	Gland packing		Inorganic fiber packing		
	Gasket		Expanded graphite sheet		
Color	Body of FC200: gray (equivalent to M5B 4/1) Body of SCS13A: none				
Attaching actuator	Integrated with the valve				
Valve position Indication	Indicated by the groove on the tip of the valve stem.				

* Closed-off rating for the products manufactured from Jan. 7, 2008 to Jun. 30, 2009 (date code: 0804–0924) is 0.4 MPa. 0.5 MPa is applied for the products manufactured on Jul. 1, 2009 or later (date code: 0928 or later).

● Actuator

Item	Specification		
Power supply	24 V AC \pm 15 %, 50/60 Hz		
Power consumption	Standard torque type	Nominal 135 Ω feedback potentiometer	7 VA
		Nominal 135 Ω resistance Input	8 VA
		4–20 mA DC input	
		2–10 V DC input	
	High voltage output type	Nominal 135 Ω feedback potentiometer	9 VA
		Nominal 135 Ω resistance Input	10 VA
		4–20 mA DC input	
		2–10 V DC input	
Actuator	For valve size DN15 to DN125	Standard torque type	
	For valve size DN150	High voltage output type	
Operation time	63 \pm 5 s (50 Hz) , 53 \pm 5 s (60Hz)		
Control signals	Nominal 135 Ω feedback potentiometer	Feedback potentiometer: total resistance = nominal 135 Ω Max. applied voltage: 5 V DC	
	Nominal 135 Ω resistance Input		
	4–20 mA DC input	Input impedance: 100 Ω	
	2–10 V DC input	Input impedance: 150 k Ω or more	
2–10 V DC output signal for valve position (applied for the 4–20 mA DC input and 2–10 V DC Input)	Output voltage range	2 V DC (fully closed) to 10 V DC (fully open)	
	Maximum load resistance	10 k Ω or more (max. output current: 1 mA)	
Valve position indication	Indicator: 0 (fully closed) to 100 (fully open) Can be seen from the forward, backward, or lower position.		
Cable	Screwed on the terminal block (M3.5) , tightening torque 0.8–1.0 N•m Note: Open an appropriate knockout hole (dia. 22) located on both sides of the actuator at the worksite.		
Enclosure protection	IEC IP54 (dust-proof, splash-proof)		
Factory preset position	Fully open		
Major materials	Case	Aluminum diecast	
	Top cover, terminal cover	Polycarbonate resin (color: gray (equivalent to DIC-651))	
	Yoke	Steel plate	
Surface finishing	Case	None	
	Yoke	Electro-galvanizing (bright chromate finish)	

■ Dimensions

● Model VY51_3 (valve body: FC200)

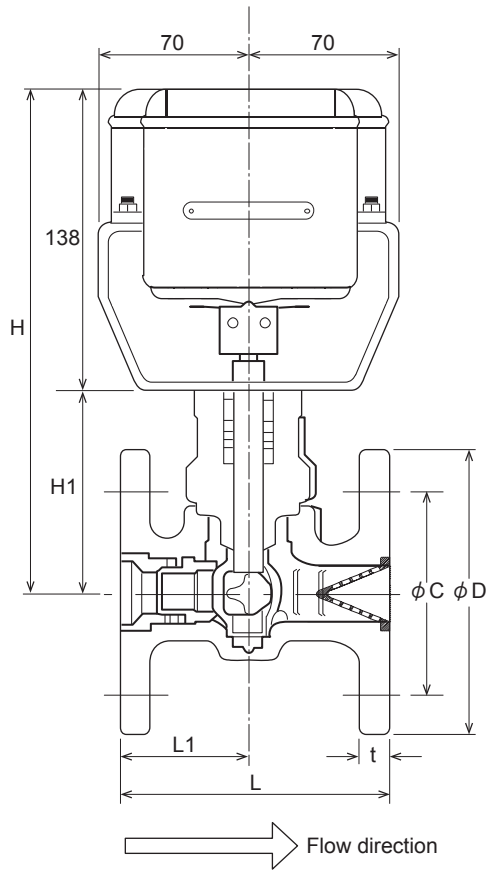

Figuar 2 Dimensions (for DN15 to DN80) (mm)

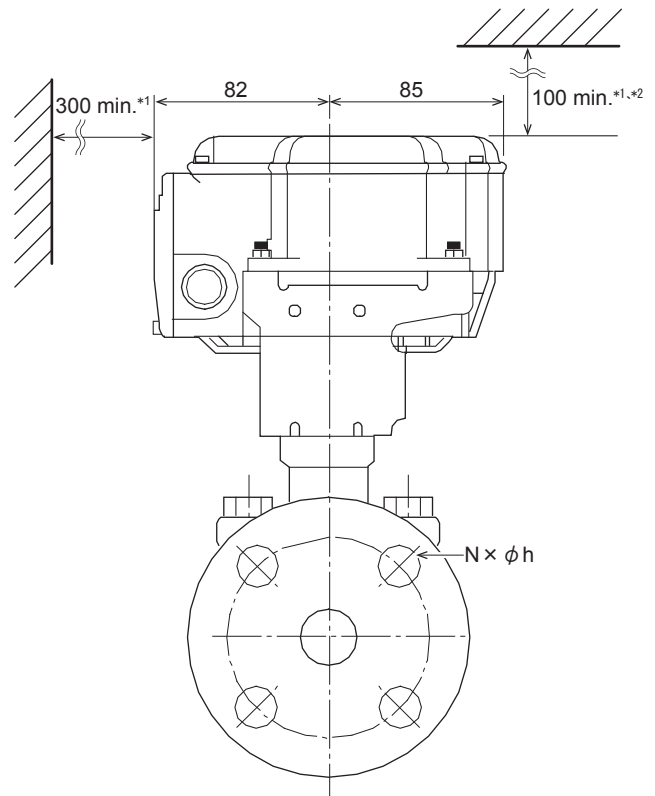

*1 Clearance for maintenance.

*2 For setting the auxiliary switch, make sure to allow a clearance of 300 mm or more.

Figuar 3 Dimensions (for DN15 to DN150, side view) (mm)

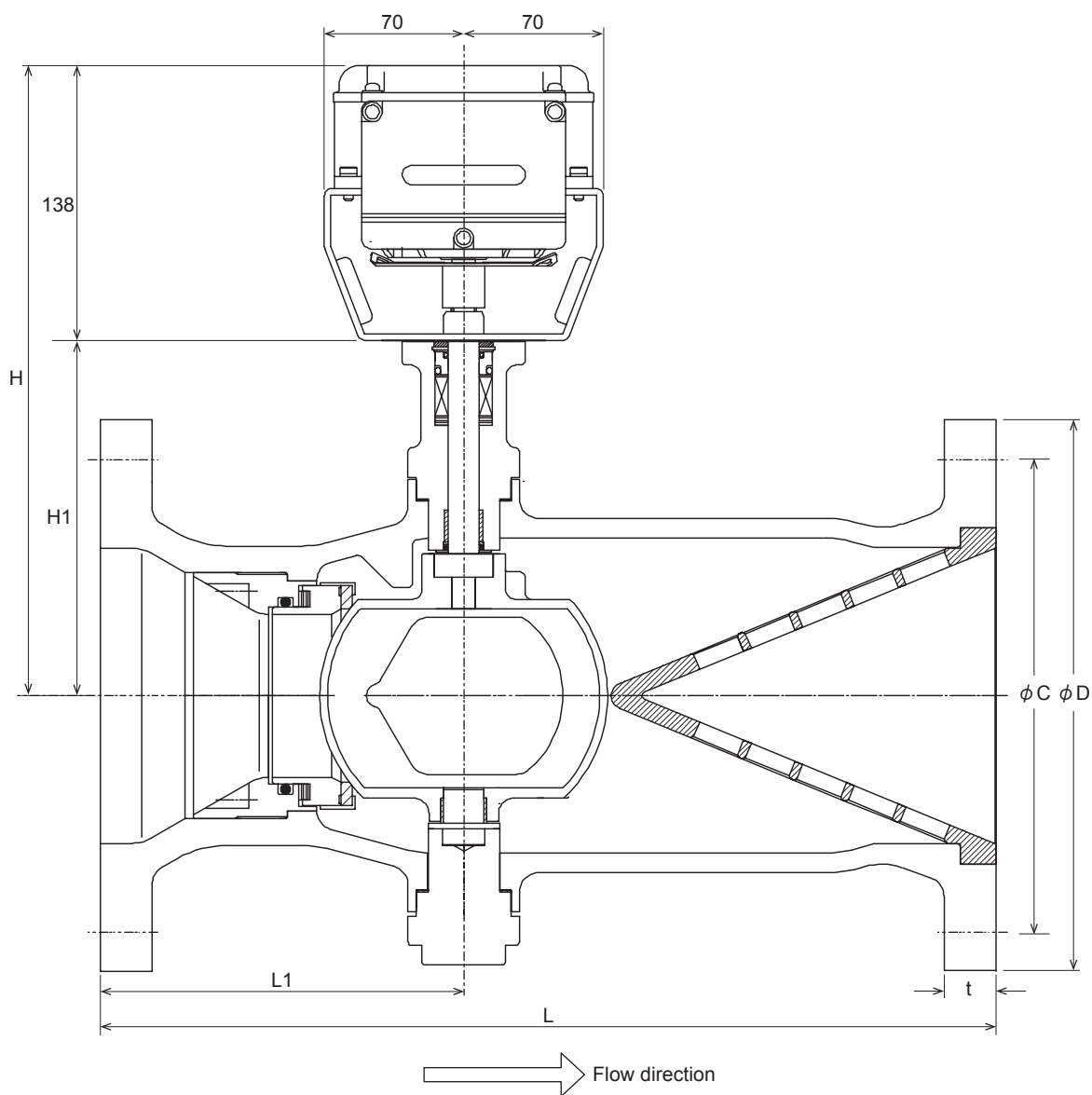

Note: For DN100, the shape of top lid is different.

Figur 4 Dimensions (for DN100 to DN150, front view) (mm)

Table 1 Dimension table (mm)

Valve size	L	L1	H	H1	ϕD	ϕC	t	ϕh	N
DN15	108	50	213	75	95	70	16	15	4
DN25	127	60	228	90	125	90	18	19	4
DN40	165	82.5	241	103	140	105	20	19	4
DN50	178	89	245	107	155	120	20	19	4
DN65	190	90	262	124	175	140	22	19	4
DN80	203	100	263	125	185	150	22	19	8
DN100	352	153	309.5	171.5	210	175	24	19	8
DN125	403	172	309.5	171.5	250	210	24	23	8
DN150	451	183	318	180	280	240	26	23	8

● Model VY51_4 (valve body: SCS13A)

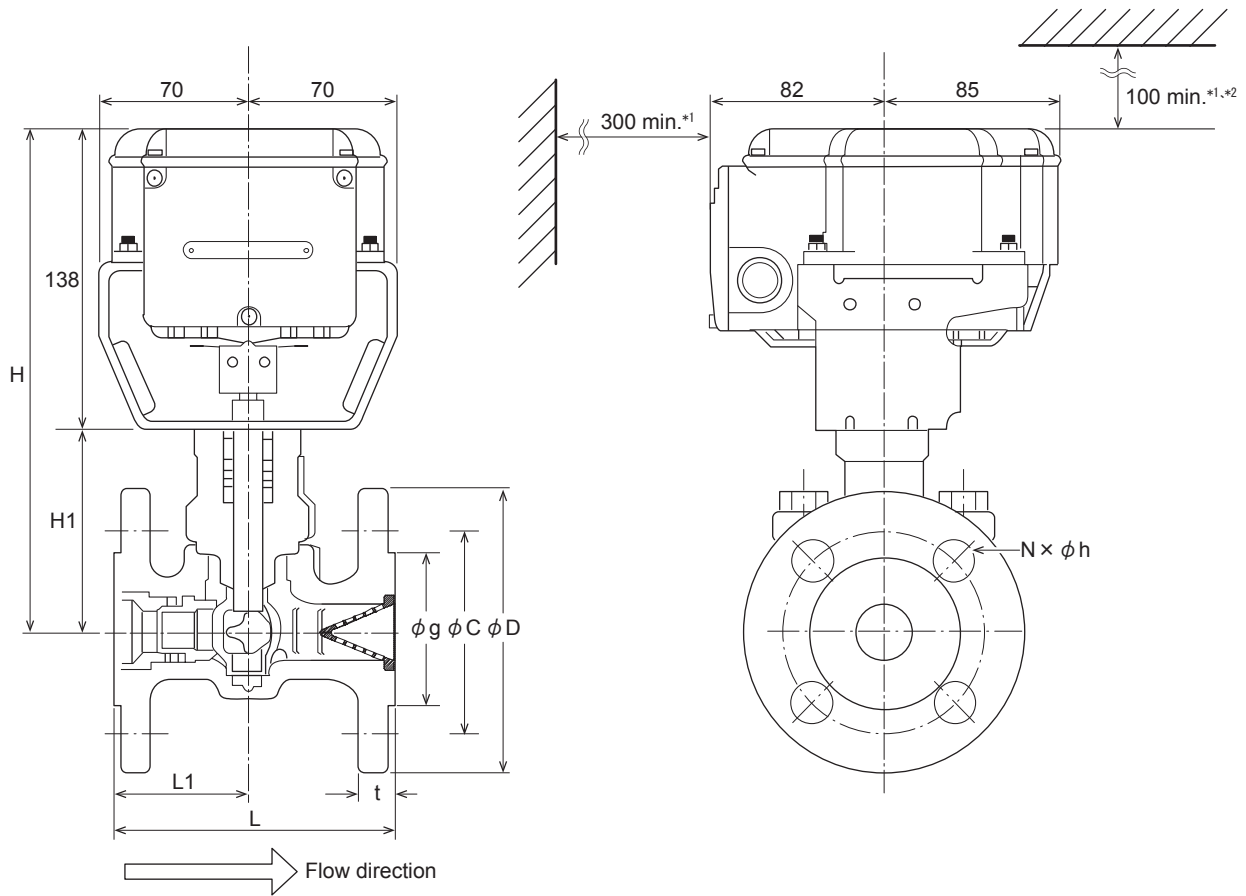

*1 Clearance for maintenance.

*2 For setting the auxiliary switch, make sure to allow a clearance of 300 mm or more.

Figuar 5 Dimensions (mm)

Table 2 Dimension table (mm)

Valve size	L	L1	H	H1	ϕD	ϕC	ϕg	t	ϕh	N
DN15	108	50	213	75	95	70	51	12	15	4
DN25	127	60	228	90	125	90	67	14	19	4
DN40	165	82.5	241	103	140	105	81	16	19	4
DN50	178	89	245	107	155	120	96	16	19	4
DN65	190	90	262	124	175	140	116	18	19	4
DN80	203	100	263	125	185	150	126	18	19	8

Parts Identification

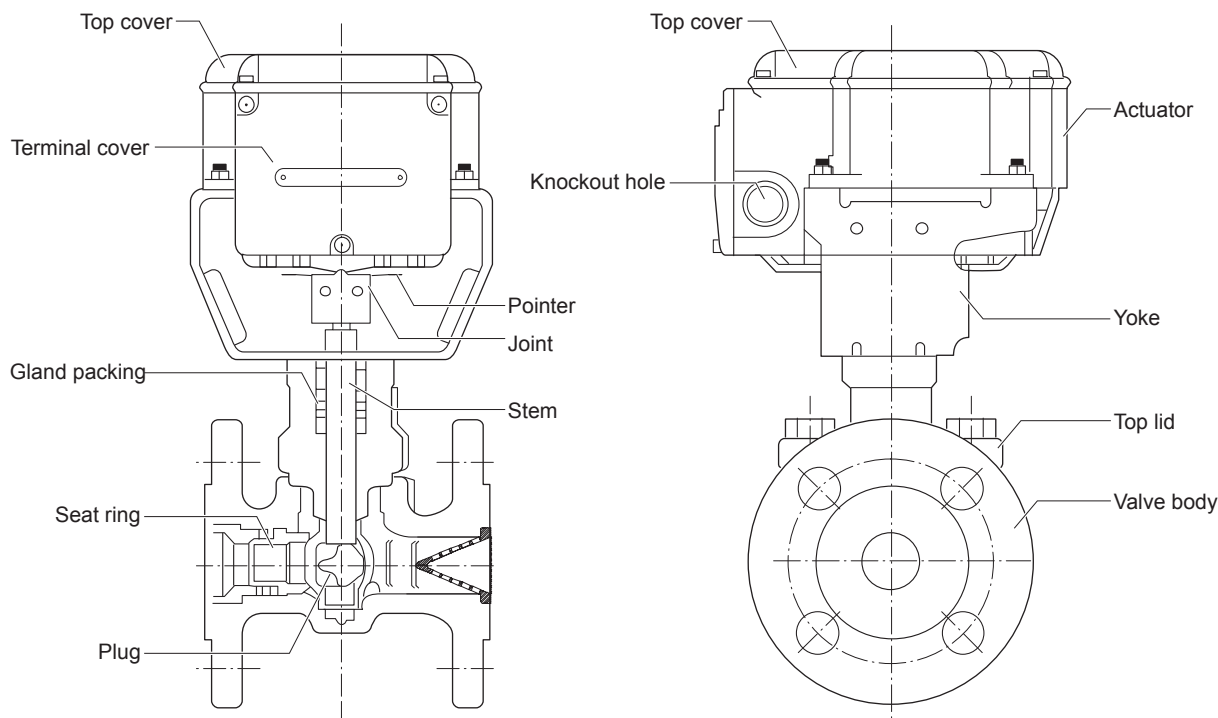

Figuar 6 Parts identification

Conditions for Avoiding Cavitation Erosion

Occurrence of the cavitation erosion is judged by the pressure ratio X_F .

$$\text{Pressure ratio } X_F = \frac{P_1 - P_2}{P_1 - P_V}$$

X_F : Pressure ratio, kPa (abs)

P_1 : Valve absolute pressure at inlet, kPa (abs)

P_2 : Valve absolute pressure at outlet, kPa (abs)

P_V : Saturated vapor pressure of fluid, kPa (abs)

Note: Saturated vapor pressure varies depending on the temperature of fluid.

IMPORTANT

- Use the product within the range of "pressure ratio $X_F < 0.7$."
If the condition above is not satisfied, the cavitation erosion may occur.

Note: This condition is just for preventing the cavitation erosion.
Cavitation itself can occur.

In addition, there is also a simple judgment method for preventing the cavitation erosion by checking the flow velocity when the valve position is 100 %.

Refer to the conditions in Table. 3, "Flow velocity through the valve joint (m/s) ."

If the conditions are not satisfied, the cavitation erosion may occur.

Table 3 Fluid velocity through the valve joint (m/s)

Chilled water	< 7.0
Hot water	< 5.0

$$\text{Flow velocity} = 21.22 \times \frac{Q}{d^2}$$

Q: Flow rate (l/min)

d: Valve diameter (DN)

■ Installation

⚠ WARNING	
!	When handling or transporting any heavy product (more than 18 kg), carefully move the product with a handtruck or the like, or with 2 or more people.
	Careless lifting or accidental dropping of the product may result in injury or product damage.

⚠ CAUTION	
⊘	Do not freeze this product. Doing so may damage the valve body and cause leakage.
	When piping this product, be sure there is no foreign matter in the pipes. If foreign matter remains in the pipes, the product may break down.
!	Install, wire, and use this product under the conditions specified by this manual. Failure to do so may cause fire or device failure.
	Use full face gaskets for flat face flanges. Failure to do so may damage the flanges or cause leakage outside of the valve.

● Precautions for installation

Observe the following cautions in order to avoid failure of this product.

- Do not strike or jar this product.
- Be sure there is no foreign matter in the pipes.
Observe the following instructions to remove foreign matter.
 - Install a strainer on the upstream side of the product.
For chilled/hot water: 40 or more mesh
 - If the strainer cannot be installed just before the inlet of each valve, install it on the pipe diverting sections for each piping group.
- Do not install this product near a steam coil, hot-water coil, etc. High-temperature radiant heat may cause failure of the actuator.
- Avoid connecting the product to piping where water hammer may occur or slag, etc. easily collects.
- For the valves whose size is DN100 or more, after mounting the valves, remove the cushioning material attached with the valves when they are delivered.

In addition, observe the following cautions.

- Install a bypass pipe and gate valves on the inflow, outflow, and bypass sides.

- Install the product so that maintenance and inspection can be done easily.
Refer to ■ "Dimensions."
- When installing the product in the ceiling, provide a trapdoor within 50 cm around the valve. And, place a drain pan under the valve.

● Mounting position

Install the product so that fluid flows in the direction pointed by the arrow on the body. It can be mounted in any position ranging from upright to sideways (90° tilted).

Note: If the product is installed outdoors, place it in upright position.

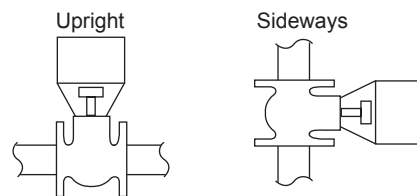

Figuar 7 Correct mounting

Actuator is below the valve.

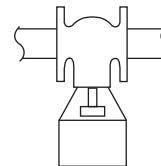

Figuar 8 Incorrect mounting

● Piping

⚠ CAUTION	
!	When installing this product, hold it in the proper position and securely fasten it to the pipes.
	Excessive tightening or improper installation position may damage the valve.

- (1) Check that the model number of the product is what you ordered. The model number is shown on the label attached on the yoke.
- (2) Install the valve so that fluid flows in the direction pointed by the arrow on the valve body.
Refer to ● "Mounting position."
 - When piping, do not apply too much sealing material, such as solidifying liquid and tape, to the pipe connection sections.
 - Do not allow chippings, sealing material, etc. to get into the pipes.

The foreign matter, such as chippings, seal material for screwing the pipes, may be caught in, resulting damages on the valve seat and the valve may not be fully closed.

Note: For the valves whose size is DN100 or more, remove the cushioning material.

(3) Fully open the valve and flush the pipes at the maximum flow rate.

When fluid flows for the first time, it is to clean out the foreign matter and refuse in the pipes.

The valve is set to fully open when it is shipped from the factory.

⚠ CAUTION	
!	After installation, make sure no fluid leaks from the valve-pipe connections. Improper piping may cause fluid leakage outside of the valve.
	Do not put a load or weight on this product. Doing so may damage the product.

● Heat insulation

- Apply heat insulation in the area illustrated by  in Fig. 9.
- If the heat insulation material is placed above the yoke, the indicator may be hidden from sight or be deformed by being entangled with the insulation material.

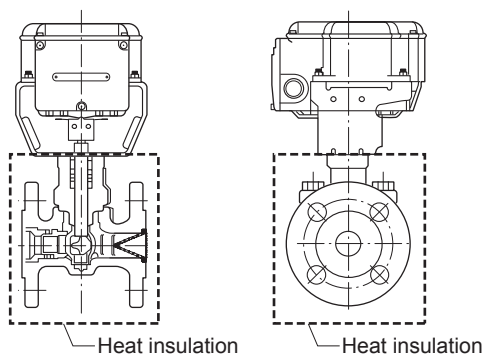

Figuar 9 Heat insulation

● Factory preset position

Actuator shaft: fully open

Pointer: completely turned clockwise

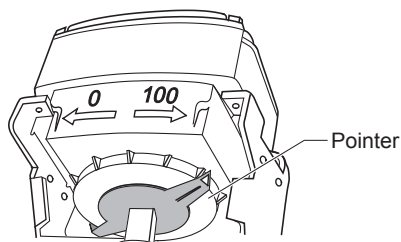

Figuar 10 Pointer position for shipment

● Manually opening/closing operation

IMPORTANT

- Before opening or closing the valve manually, turn off the power. If the valve is manually opened or closed while the power (24 V AC) is applied, the actuator may break down.
- Do not manually open or close the valve beyond the fully open or fully closed scale.

- (1) Turn off the power.
- (2) Hold the joint using a wrench, etc., gently turn the wrench to the desired position, open or close.

Note: If the valve is subject to shock, the actuator may break down.

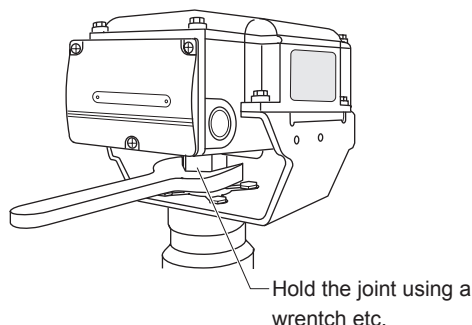

Figuar 11 Manually opening/closing operation

● Changing the actuator mounting position

IMPORTANT

- Do not break combination of the valve, yoke, and actuator.
- When changing the mounting position of the actuator, set the position to 100 % (fully open) for the valve and actuator.
If the valve and actuator are assembled in different valve positions, gears in the actuator will be damaged because the actuator will try to close or open the valve although the valve stops at the fully closed or fully open position.

(1) Remove the screws connecting the actuator and the yoke.

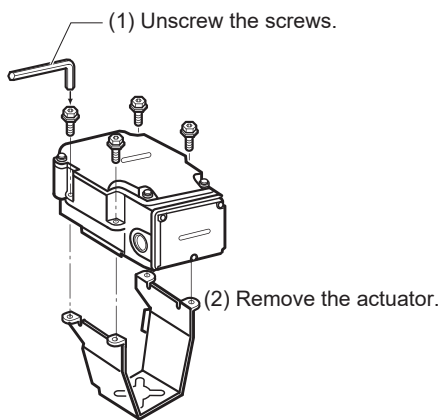

(2) Lift the actuator and detach it from the yoke.

(3) Remove the screws connecting the yoke and the valve.

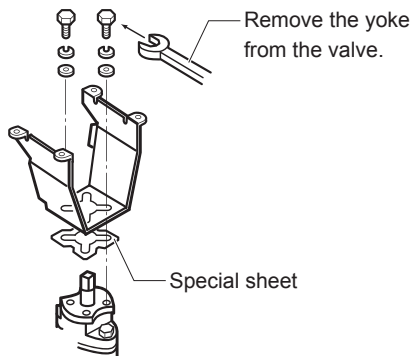

Note: A special sheet is inserted between the yoke and valve for heat insulation.
When you changed the mounting position, be careful not to lose the sheet.

(4) Make sure that the groove on the tip of the valve stem is parallel to the pipes (indicating the valve in 100 % position).

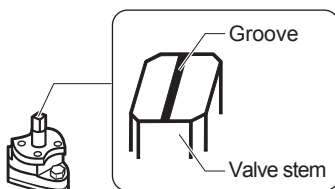

(5) Align the yoke to the desired orientation.
Orientation of the actuator can be changed by 90° steps from the factory preset position.
(0°/90°/180°/270°)

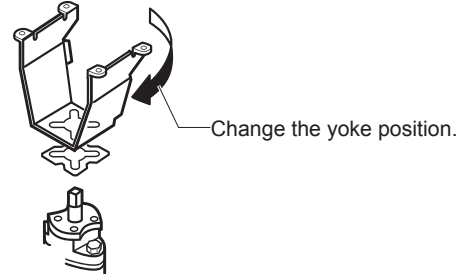

(6) Reinsert the sheet removed in step (3) between the yoke and the valve, and then mount the yoke on the valve with the screws.

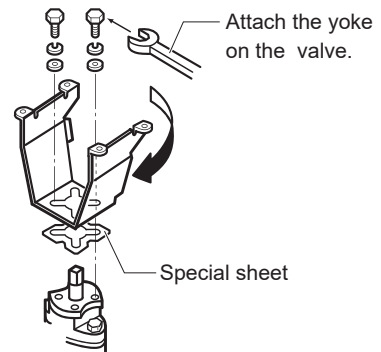

(7) Check that the pointer on the actuator indicates the fully open, and that the actuator can be properly seated on the valve stem.

(8) Mount the actuator on the yoke using the screws removed in step (1).

(9) Check that the valve smoothly operates from the fully closed to the fully open positions.

■ Wiring

⚠ CAUTION	
❗	Provide a circuit protector (e.g., a fuse or circuit breaker) for the power source. Failure to do so may cause a short circuit leading to fire or device failure.
❗	Install, wire, and use this product under the conditions specified by this manual. Failure to do so may cause fire or device failure.
❗	Installation and wiring of the actuator must be performed by personnel qualified to do instrumentation and electrical work. Mistakes in installation or wiring may cause fire or electric shock.
❗	Before wiring, be sure to turn off the power to this product. Failure to do so may result in electric shock or device failure.
❗	All wiring must comply with applicable codes and ordinances. Otherwise there is a danger of fire.
❗	Use crimp terminals with insulation for connections to the product terminals. Failure to do so may cause short circuit leading to fire or device failure.
❗	Tighten the terminal screws with the specified torque. Insufficient tightening of the terminal screws may cause fire or overheating.

IMPORTANT

- This product is designed for 24 V AC power supply voltage. Do not apply power supply voltage other than 24 V AC.
- For the 2-10 V DC input type and the 4-20 mA input type, check the polarity of the power supply and 2-10 V DC feedback signal, and then correctly wire the product. Incorrect wiring may result in PCB (print circuit board) burnout.

● How to maintain IP54 (dust-proof, splash-proof)

In order to maintain IP54 performance, use a waterproof connector or a water-resistant plica tube when the product is used in high humidity environment or outdoor.

- Be sure to completely close the terminal cover and top cover.
- Apply a waterproofing treatment for the knockout hole.
- For cable connection, use the waterproof connector (to be ordered separately).
- For conduit connection, use the waterproof plica tubes etc.

● Control signals type

The type of control signals is printed on the actuator label and the wiring diagram label as shown below.

F.B. Pot	: Nominal 135 Ω feedback potentiometer (F motor)
135 Ω	: Nominal 135 Ω resistance input (E motor)
4–20 mA	: 4–20 mA DC input
2–10V	: 2–10 V DC Input

● Wiring procedure

- (1) Select a knockout hole according to the wire outlet direction, and open a knockout hole. Two knockout holes are provided on the bilateral sides of the actuator. The knockout holes can be easily opened by lightly knocking the hole using a screwdriver.

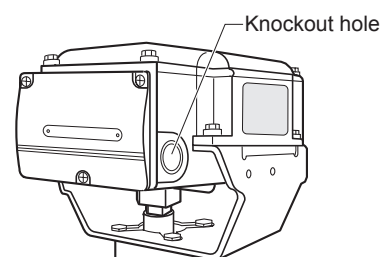

IMPORTANT

- Do not leave pieces of metal (generated by making the knockout hole) inside the actuator.

- (2) Unscrew the 3 setscrews (M4 x 10) on the terminal cover to remove the cover.

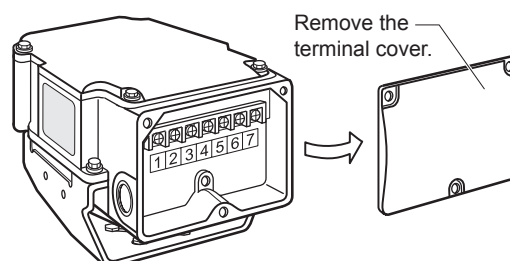
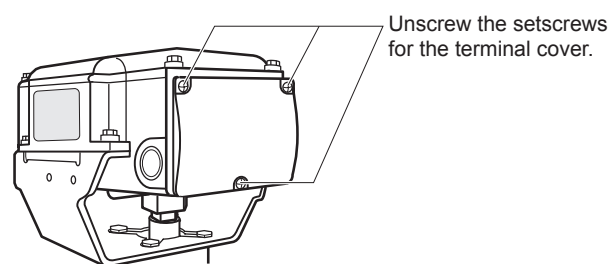

- (3) Correctly connect the wires to the terminals with the M3.5 screw terminal screws. Do not apply 24 V AC to terminals 4 to 7.

Note: Correctly connect the wires referring to Fig. 12 to Fig. 16, "Terminals Connection", Fig. 17 to Fig. 30, "Wiring Examples" and "Advanced Wiring Examples."

(4) Mount the terminal cover and attach it with the setscrews.

⚠ CAUTION

! After wiring, be sure to reattach the cover. Failure to do so may result in electric shock.

■ Terminals Connection

● Nominal 135 Ω feedback potentiometer

(Model VY511_J0_...)

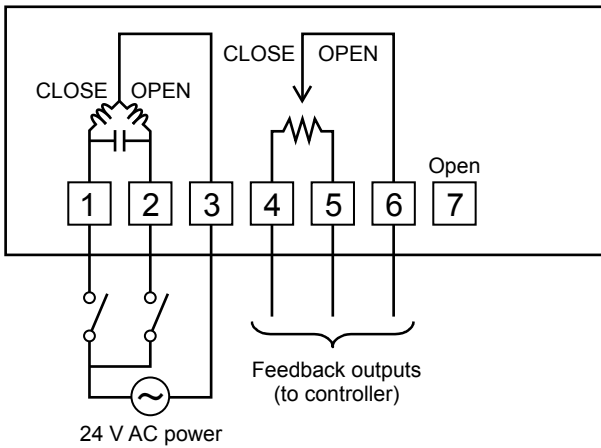

Note: The controller that reads the voltage between terminals 4 and 6 as a feedback signal is recommended.
Figuar 12

Recommended controller circuit

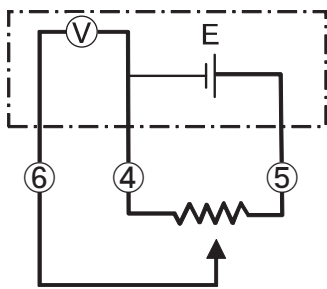

Note: If a third-party's controller is used combining with the product, the controller in above is to be used.

- ⋯: Recommended controller circuit
 - E : Voltage supplied by the controller
 - ⓧ : Voltage between 4 and 6.
- Figuar 13

● Nominal 135 Ω resistance input

(Model VY512_J0_...)

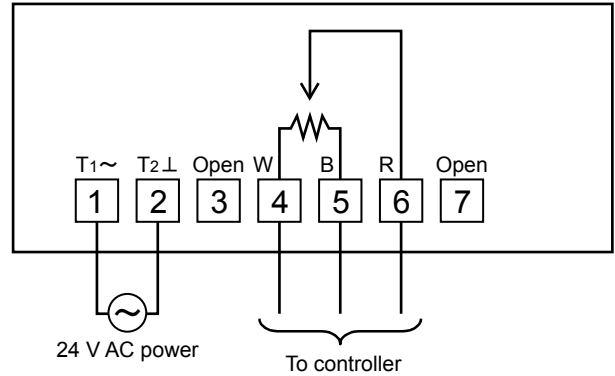

Figuar 14

● 4–20 mA DC input

(Model VY513_J0_...)

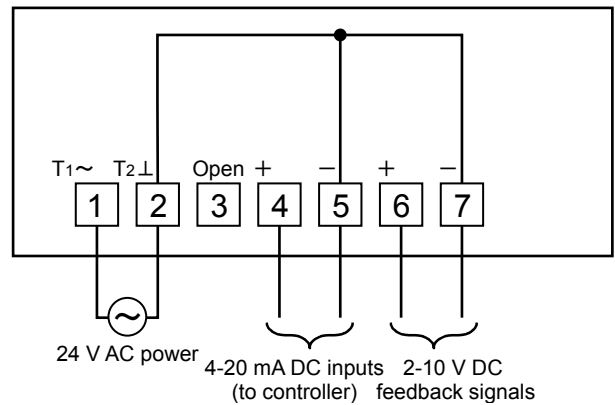

Note: The terminal 2 (power), terminal 5 (4–20 mA DC input), and terminal 7 (2–10 V DC feedback signal) are internally connected.

Figuar 15

● 2–10 V DC input

(Model VY514_J0_...)

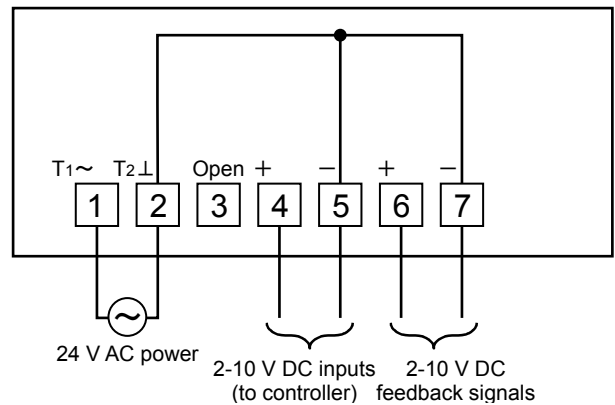

Note: The terminal 2 (power), terminal 5 (2–10 V DC input), and terminal 7 (2–10 V DC feedback signal) are internally connected.

Figuar 16

■ Wiring Examples

● Nominal 135 Ω feedback potentiometer

(Model VY511_)

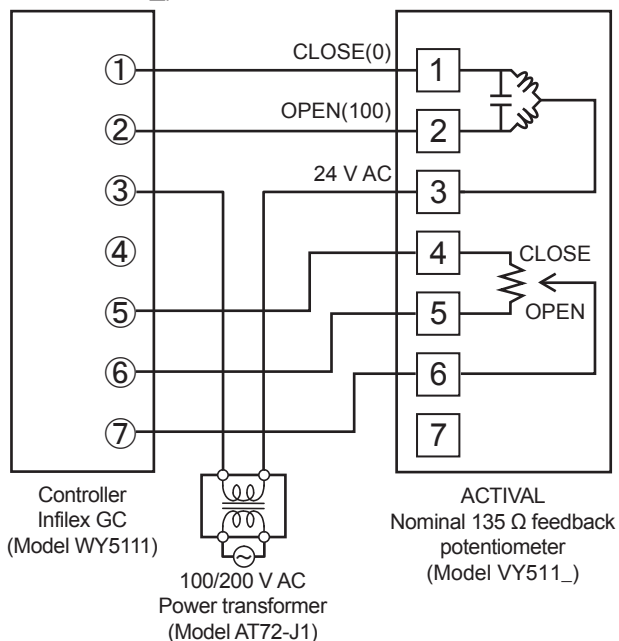

Figuar 17 Connection to Inflex GC

● Nominal 135 Ω resistance Input

(Model VY512_)

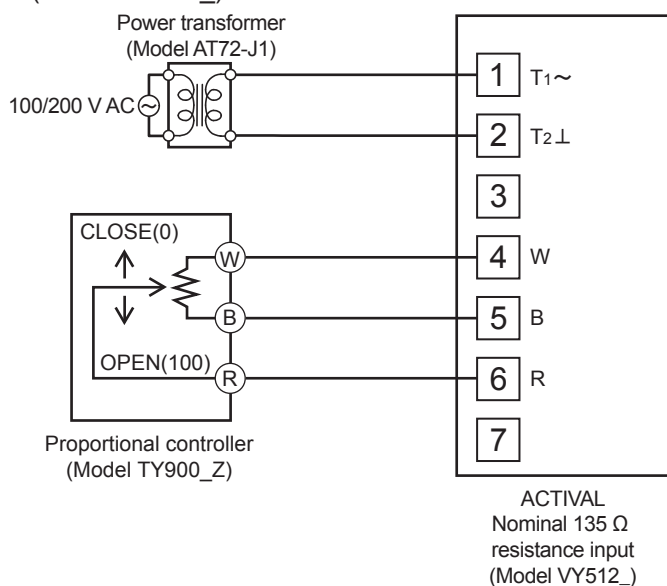

Figuar 18 Connection to Neostat

● 4–20 mA DC input

(Model VY513_)

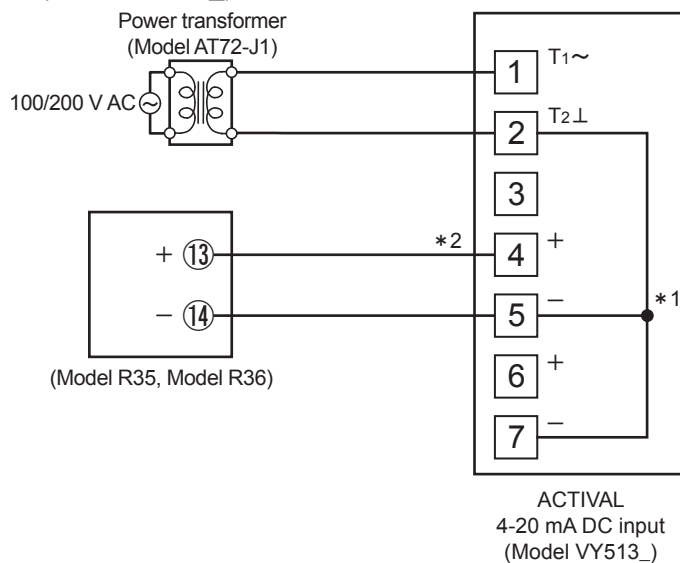

*1 The terminal 2 (power), terminal 5 (4–20 mA DC input), and terminal 7 (2–10 V DC feedback signal) are internally connected.

*2 Input impedance of 4–20 mA DC input of the actuator is 100 Ω.
4–20 mA DC input is not isolated. Install the power transformer separately.

Figuar 19 Connection to R-series

● 2–10 V DC input

(Model VY514_)

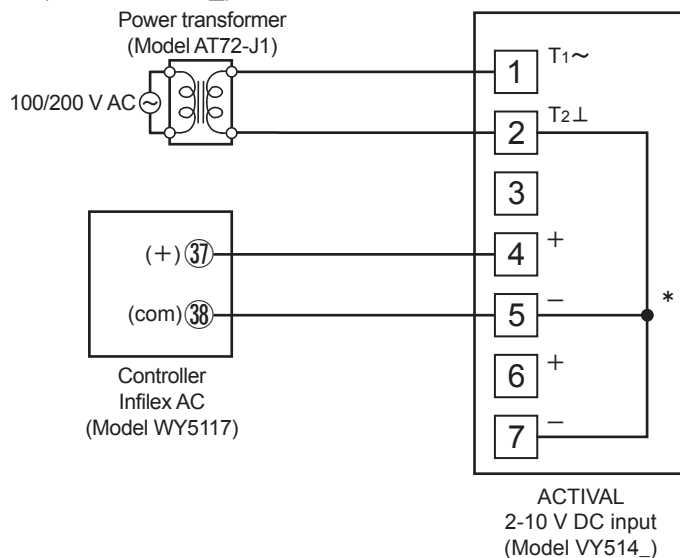

* Terminals 2, 5, and 7 are internally connected.

Note: Do not implement a daisy chain wiring passing through the actuator's power terminals.

Figuar 20 Connection to Inflex AC

Advanced Wiring Examples

Nominal 135 Ω resistance Input

(Model VY512_)

Minimum opening setting

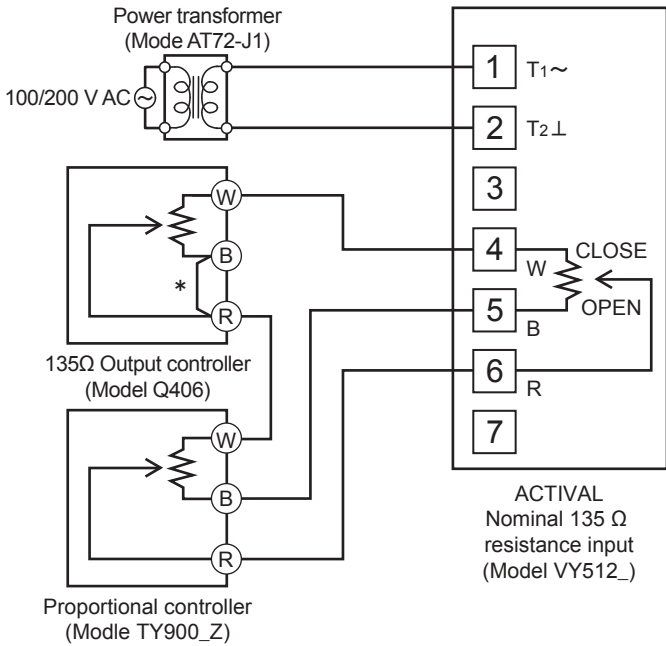

In addition to the proportional controller, by adding the setting device of 135 Ω output, the minimum opening of the actuator can be set within the range of 0 to 50 % (approximately).

* Connect between (R) and (B) with a jumper.

Note: In an abnormal condition (such as disconnection in the actuator, an abnormal input signal, failure of the feedback potentiometer due to its product service life), the minimum opening position cannot be maintained. Avoid instrumentation that may cause secondary damage in case of abnormality.

Figuar 21

Summer-winter changeover

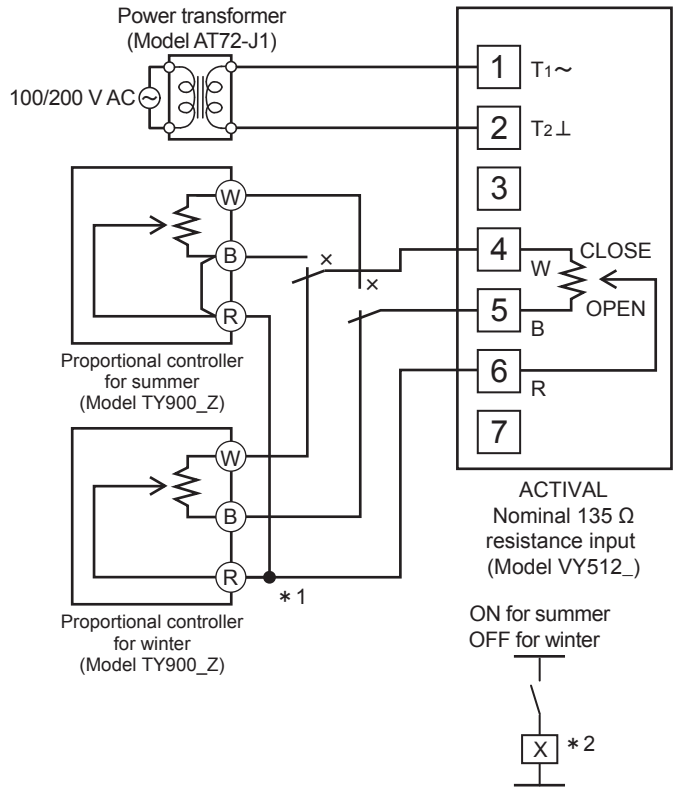

*1 Directly wire between (R) and (R).

*2 The current among W, B, and R is 5 mA or more. A relay equivalent to Model HH54P of Fuji Electric Co. can be used

Figuar 23

Using relay, interlock

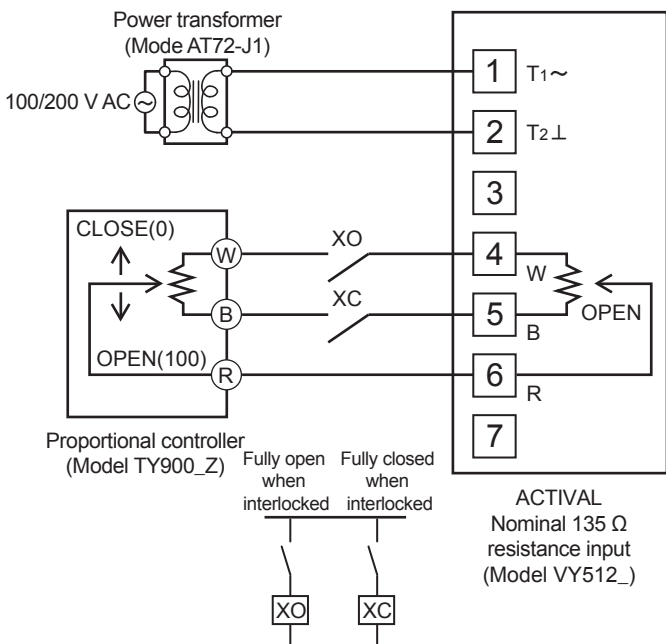

Figuar 22

● 4–20 mA DC input

(Model VY513_)

Precautions

- Power transformer is shared If a power transformer is shared by two products, connect the terminal 1 of each actuator to the transformer with the same polarity. Connect the terminal 2 in the same way. If the terminals are connected with different polarities, the product may break down (see Fig. 25).

- Control signals are shared for 4–20 mA DC input The 4–20 mA DC input signals of this product are not isolated from the power.

And, the input impedance of 4–20 mA DC signals is 100 Ω. The relations among the input impedance of the product, the output load resistance of the controller, and the output load resistance and input impedance of an isolator (if necessary) must meet the following formula.

Applicable load resistance > Total of input impedance

If two products are operated by one controller, configure the system referring to Fig. 26 for two individual transformers, Fig. 24 for a shared transformer. To share a power transformer, install an isolator to the 4–20 mA DC input terminals of the second product. Otherwise, the product will malfunction.

Input signals and power are shared

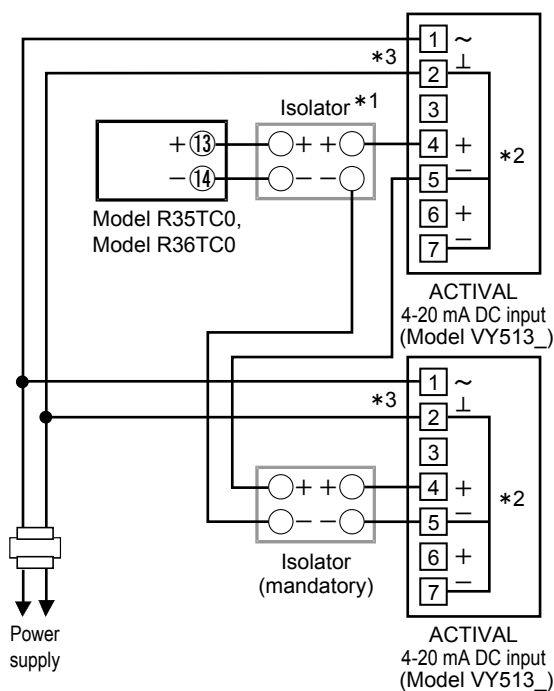

- *1 Provide an isolator for the controller that is not internally isolated.
- *2 Terminals 2, 5, and 7 are internally connected.
- *3 Refer to notes under “Power transformer is shared.”

Figur 24

Power is shared

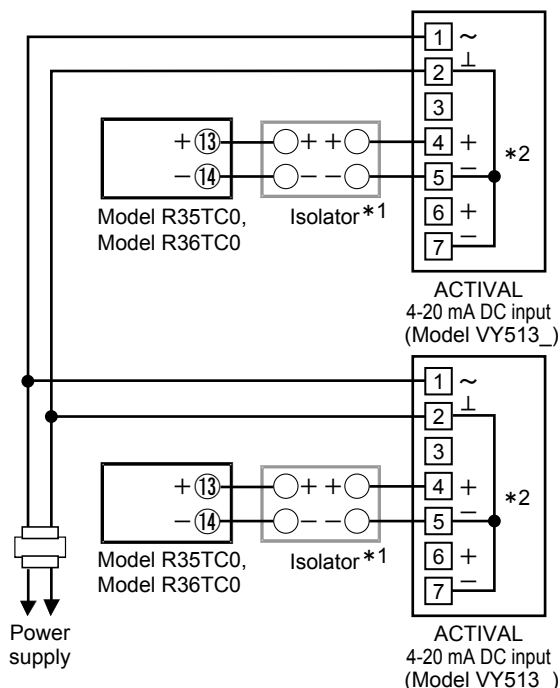

- *1 Provide an isolator for the controller that is not internally isolated.
- *2 Terminals 2, 5, and 7 are internally connected.

Figur 25

Input signals are shared

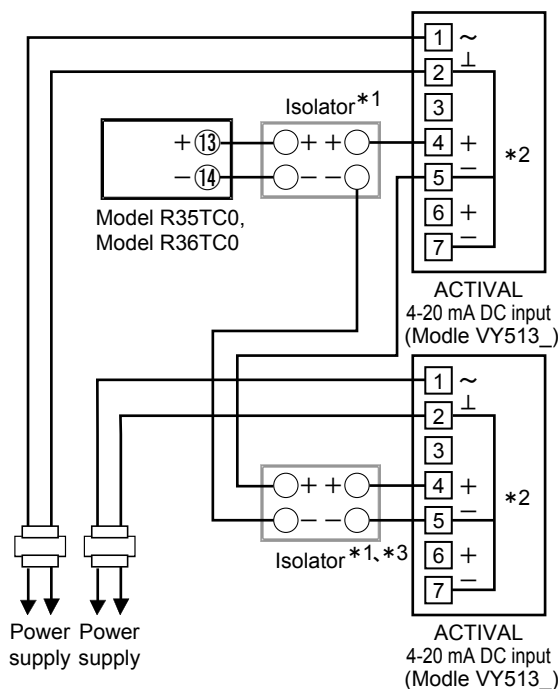

- *1 Provide an isolator for the controller not internally isolated.
- *2 Terminals 2, 5, and 7 are internally connected.
- *3 Provide an isolator if no isolator is provided to the 4–20 mA DC input of the first actuator AND the applicable load resistance of controller is less than 200 Ω.

Figur 26

● 2-10 V DC input

(Model VY514_)

Precautions

- Power transformer is shared
 If a power transformer is shared by two products, connect the terminal 1 of each actuator to the transformer with the same polarity. Connect the terminal 2 in the same way.
 If the terminals are connected with different polarities, the product may break down (see Fig. 28).

Input signals and power are shared

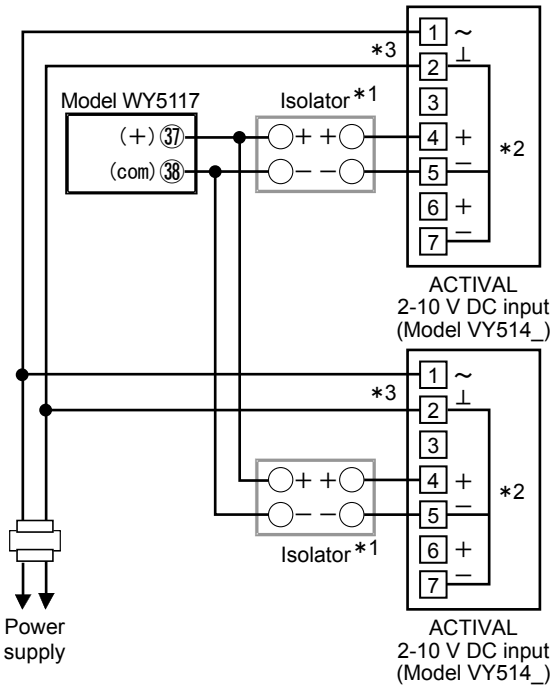

- *1 Provide an isolator for the controller that is not internally isolated.
- *2 Terminals 2, 5, and 7 are internally connected.
- *3 Refer to notes under "Power transformer is shared."

Figuar 27

Power is shared

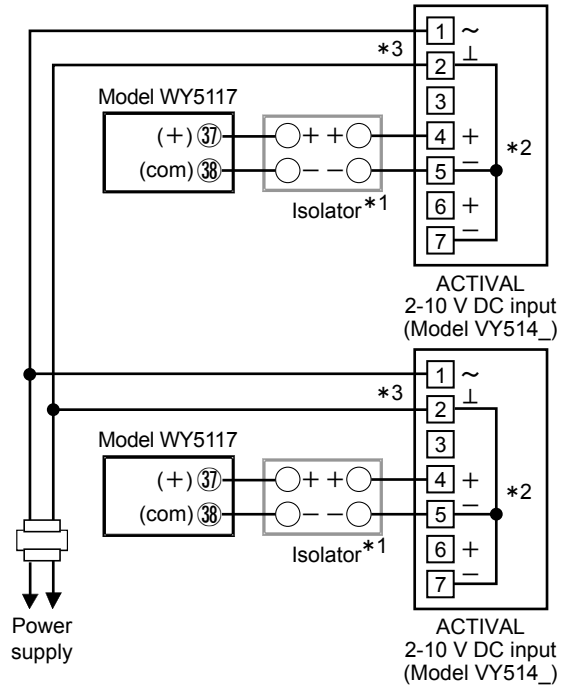

- *1 Provide an isolator for the controller that is not internally isolated.
- *2 Terminals 2, 5, and 7 are internally connected.
- *3 Refer to notes under "Power transformer is shared."

Figuar 28

Input signals are shared

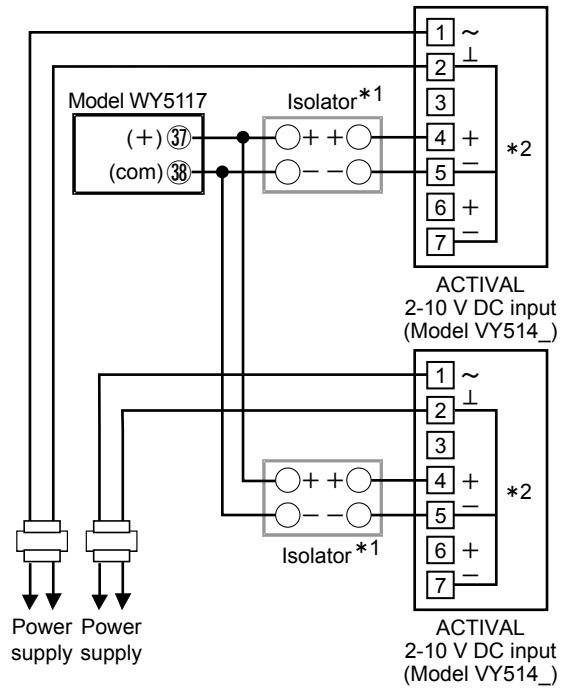

- *1 Provide an isolator for the controller not internally isolated.
- *2 Terminals 2, 5, and 7 are internally connected.

Figuar 29

● For connecting multiple products

Nominal 135 Ω feedback potentiometer (Model VY511_)

Or, for connecting the nominal 135 Ω resistance input (Model VY512_) and the “nominal 135 Ω resistance input.”

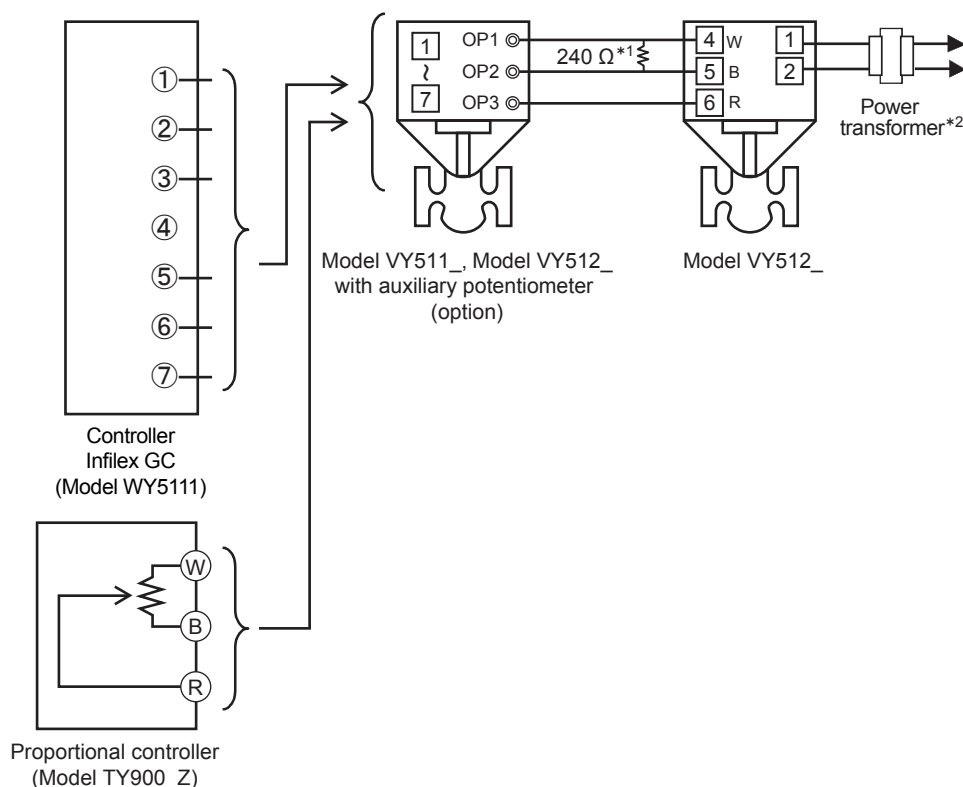

*1 If two auxiliary potentiometers (option) are connected to ACTIVAL, connect the $240 \pm 5\% \Omega$ resistor, which is included in the auxiliary potentiometer kit, between W and B.

*2 Generally use an isolated transformer such as Model AT72-JI for a valve, and do not share the transformer with other devices such as sensor, transmitter.

Figuar 30

■ Maintenance

⚠ CAUTION	
⊘	Do not put a load or weight on this product. Doing so may damage the product.
!	Before doing maintenance, be sure to turn off the power to this product. Failure to do so may result in electric shock or device failure.
!	After maintenance, be sure to reattach the terminal cover. Failure to do so may result in electric shock.
⊘	Do not carelessly touch this product when it is used to control hot water. Doing so may result in burns, because the product reaches a high temperature.

- After piping the product, if it is not operated for a long period, execute valve open and close operations once a month or so.
 - Execute maintenance according to table 4.
 - Once every six months or so, visually check that there is no leakage of fluid to the outside of the valve and the actuator operates smoothly.
- if a trouble occurs as described in Table 5, take appropriate measures according to the symptom. Although the measures are taken, if the trouble cannot be recovered, please contact Azbil Corporation.

Table 4 Inspection items and inspection method

Item	Inspection cycle	Inspection method
Visual check	6 months	<ul style="list-style-type: none"> • There is no leakage from the gland and flange. • Loose bolts. • There is no damage on the valve and actuator.
Operation status	6 months	<ul style="list-style-type: none"> • The valve is smoothly opened or closed. • Check that no abnormal sound or vibration is observed.
Daily inspection	Any time	<ul style="list-style-type: none"> • Check that there is no leakage of fluid to the outside of the valve. • Check that no abnormal sound or vibration is observed. • The valve is smoothly opened or closed. • Check that there is no hunting observed with the valve.

Table 5 Troubleshooting

Abnormal phenomenon	Where to inspect	Measure
Leakage from the flange	Loose flange bolts Gasket on the flange. Misaligned pipes	Retighten the flange bolts. Replace the gasket. Do piping again.
Leakage from the gland	-----	Contact Azbil Corporation
Leakage from the top lid joint	Loose bolts	Retighten the bolts.
The valve is not smoothly opened or closed. The valve stops halfway. The valve does not move.	Check that the power line and the input signal are correctly fed. Loose terminals Check that wires are firmly connected, no disconnected wire.	Check the power supply voltage and the controller. Retighten the terminals. Check the wirings.
Leakage is observed when the valve is fully closed.	Pointer position when the valve is fully closed	Fully close the valve.
Abnormal sound or vibration is observed.	Check that level of pressure at the primary is adequate. Check the level of differential pressure.	Adjust the mounting conditions.
The auxiliary switch does not work.	Check the conditions of the auxiliary switch cam. Loose terminals Check that wires are firmly connected, no disconnected wire.	Do settings again. Retighten the terminals. Check the wirings.
The auxiliary potentiometer does not work.	Resistance value Loose terminals Check that wires are firmly connected, no disconnected wire.	Check the resistance. (1 kΩ) Retighten the terminals. Check the wirings.
Valve hunting	Level of pressure and differential pressure at the secondary Stability of control	Adjust the mounting conditions. Adjust the settings of control parameter such as PI.
Mismatch between the input signal and the feedback signal in the voltage/current input specifications	-----	If the input specification is voltage or current, the valve moves from 0 % to 100 % corresponding to the input signal from 10 % to 90 % in order to fully close the valve. Therefore, the input signal and the feedback signal do not match, but it is not abnormal.

■ Disposal

Dispose of this product as industrial waste in accordance with your local regulations.
Do not reuse all or any part of the product.

This blank page was added for page layout purposes.

 This product complies with the following harmonised standards of the Electromagnetic Compatibility Directive (EMCD) .
EMCD: EN 61000-6-2
EN 55011 Class A, Group 1

* ACTIVAL is a trademark of Azbil Corporation.
* Inflex is a trademark of Azbil Corporation.

Azbil Corporation
Building Systems Company

1-12-2 Kawana, Fujisawa, Kanagawa
251-8522 JAPAN
<https://www.azbil.com/>

azbil

Specifications are subject to change without notice.