

savic-net™ G5 Supervisory Controller

■ Overview

This product (Model BH-101G0_0000-U) is a Supervisory Controller that collects information about a primary device (such as a controller) and provides that information to the Client PC in savic-net™ G5, Azbil Corporation's building management system.

This product receives point information from the primary device through periodic scan or state change notifications and accumulates and manages various kinds of control-related data.

In addition, the software that can be downloaded from this product allows you to monitor its state using graphics and lists, set up several different kinds of controls including interlock controls and scheduling, view data such as charts as well as daily, weekly, monthly and yearly reports, and perform other operations from the Client PC.

This product can also provide information to a third-party BACnet device.



■ Features

Any combination of the following applications is available as required.

- Equipment status monitoring

This product monitors up to 5000 points of the data below.

It is possible to connect up to 30 Supervisory Controllers to monitor up to 150,000 points.

Each Supervisory Controller can also be configured for redundancy. (If a redundancy configuration is implemented, up to 60 Supervisory Controllers can be connected.)

 - Point information in the primary device
 - Direct inputs to ensure immediate detection of power supply state and fire alarms from a building
- Comprehensive control

This product comprehensively controls the devices connected to the system to realize comfort, safety, and energy efficiency.

- Data management

This product stores and manages the following data:

 - Data collected from the devices connected to this product
 - Data transmitted from the devices connected to this product
 - Data that has been processed for daily, weekly, monthly, and yearly reports based on the collected and transmitted data
- Data visualization

By using the software that comes with this product, you can display graphics, charts, and daily, weekly, monthly, and yearly reports on the screen of a Client PC or output them to a file.

Safety Precautions

Please read instructions carefully and use the product as specified in this manual. Be sure to keep this manual nearby for quick reference.

Restrictions on Use

This product was developed, designed, and manufactured for general air conditioning use. Do not use the product in a situation where human life may be at risk or for nuclear applications in radiation controlled areas. If you wish to use the product in a radiation controlled area, please contact Azbil Corporation. Particularly when the product is used in the following applications where safety is required, implementation of fail-safe design, redundant design, regular maintenance, etc., should be considered in order to use the product safely and reliably.

- Safety devices for protecting the human body
- Start/stop control devices for transportation machines
- Aeronautical/aerospace machines

For system design, application design, instructions for use, or product applications, please contact Azbil Corporation.

Azbil Corporation bears no responsibility for any result, or lack of result, deriving from the customer's use of the product.

Caution for Instrumentation Design

Considering unexpected failures or contingencies, be sure to design and check safety of the system and equipment.

Recommended Design Life

It is recommended that this product be used within the recommended design life. The recommended design life is the period during which you can use the product safely and reliably based on the design specifications. If the product is used beyond this period, its failure ratio may increase due to time-related deterioration of parts, etc. The recommended design life during which the product can operate reliably with the lowest failure ratio and least deterioration over time is estimated scientifically based on acceleration tests, endurance tests, etc., taking into consideration the operating environment, conditions, and frequency of use as basic parameters. The recommended design life of this product is 10 years. The recommended design life assumes that maintenance, such as replacement of the limited life parts, is carried out properly. Refer to the section on maintenance in this manual.

Caution for Transporting

Lithium batteries are used in this product. When this product, which uses lithium batteries, is transported by air or sea, ship it in accordance with IATA-DGR/IMDG-Code regulations. Please inform your shipping company that lithium batteries are included in the product, and follow the necessary procedures according to the company's instructions. If the product is shipped by air or sea without the necessary labels, etc., specified by the ordinances, you may be in violation of aviation or maritime safety laws and be subject to punishment.

Warnings and Cautions



WARNING

Alerts users that improper handling may cause death or serious injury.



CAUTION

Alerts users that improper handling may cause minor injury or material loss.







Signs





















Notifies users that specific actions are prohibited to prevent possible danger. The symbol inside  graphically indicates the prohibited action. (For example, the sign on the left means that disassembly is prohibited.)



Instructs users to carry out a specific obligatory action to prevent possible danger. The symbol inside  graphically indicates the actual action to be carried out. (For example, the sign on the left indicates general instructions.)

 WARNING	
	Install this product in a location out of reach of unauthorized people. (e.g. Inside of the control panel with a lock) Failure to do so might cause electric shock.
	Ground this product with ground resistance of less than 100 Ω. Improper grounding may cause electric shock or malfunction.
	Before wiring or maintenance, turn off the power to this product. Failure to do so may result in electric shock or device failure.
	Do not insert conductive objects through product ventilation holes. Doing so may cause electric shock.
	Do not touch electrically charged parts. Doing so may cause electric shock.

 CAUTION	
	Take anti-lightning surge measures based on regional and building characteristics. Lightning may cause fire or critical damage to this product if protective measures are not taken.
	Keep the products in package for storage. Failure to do so may damage or stain the products.
	Do not drop this product. Doing so may cause an injury or may damage the device.
	Install, wire, and use this product under the conditions specified by this manual. Failure to do so may cause fire or device failure.
	Take anti-noise measures if this product is installed in a location near source of electric noise. Failure to do so may cause malfunction or device failure.
	Installation and wiring must be performed by personnel qualified to do instrumentation and electrical work. Mistakes in installation or wiring may cause fire or electric shock.
	All wiring must comply with applicable codes and ordinances. Otherwise there is a danger of fire.

 CAUTION	
	Strip the insulation from cables as specified in this manual. If the length of exposed wire is longer than specified, it may cause electric shock or short circuit between adjacent terminals. If it is too short, it may not make proper contact.
	Tighten the terminal screws with the specified torque. Insufficient tightening of the terminal screws may cause fire or overheating.
	Do not use unused/spare terminals on this product as relay terminals. Doing so may cause device failure.
	Do not block the ventilation holes of this product. Doing so may cause device failure.
	Do not allow wire clippings, metal shavings, and other refuse to enter into the product. Doing so may cause fire or product damage.
	Do not disassemble this product. Doing so may cause device failure.
	Before cleaning the product or retorquing the terminal screws, turn off the power to the product. Failure to do so may cause electric shock, device failure, or malfunction.
	Before touching this product, remove any static electrical charge from your body. Otherwise your static electricity may damage some components of the product. Static electrical charge can be removed by touching the grounded metal.
	When removing the fan, do not insert fingers into the product. Doing so may damage the internal components.
	Dispose of used lithium batteries in accordance with local regulations. Do not throw them in the fire or dispose of them with ordinary garbage. Doing so may cause the batteries to burst or ignite.

System Configuration

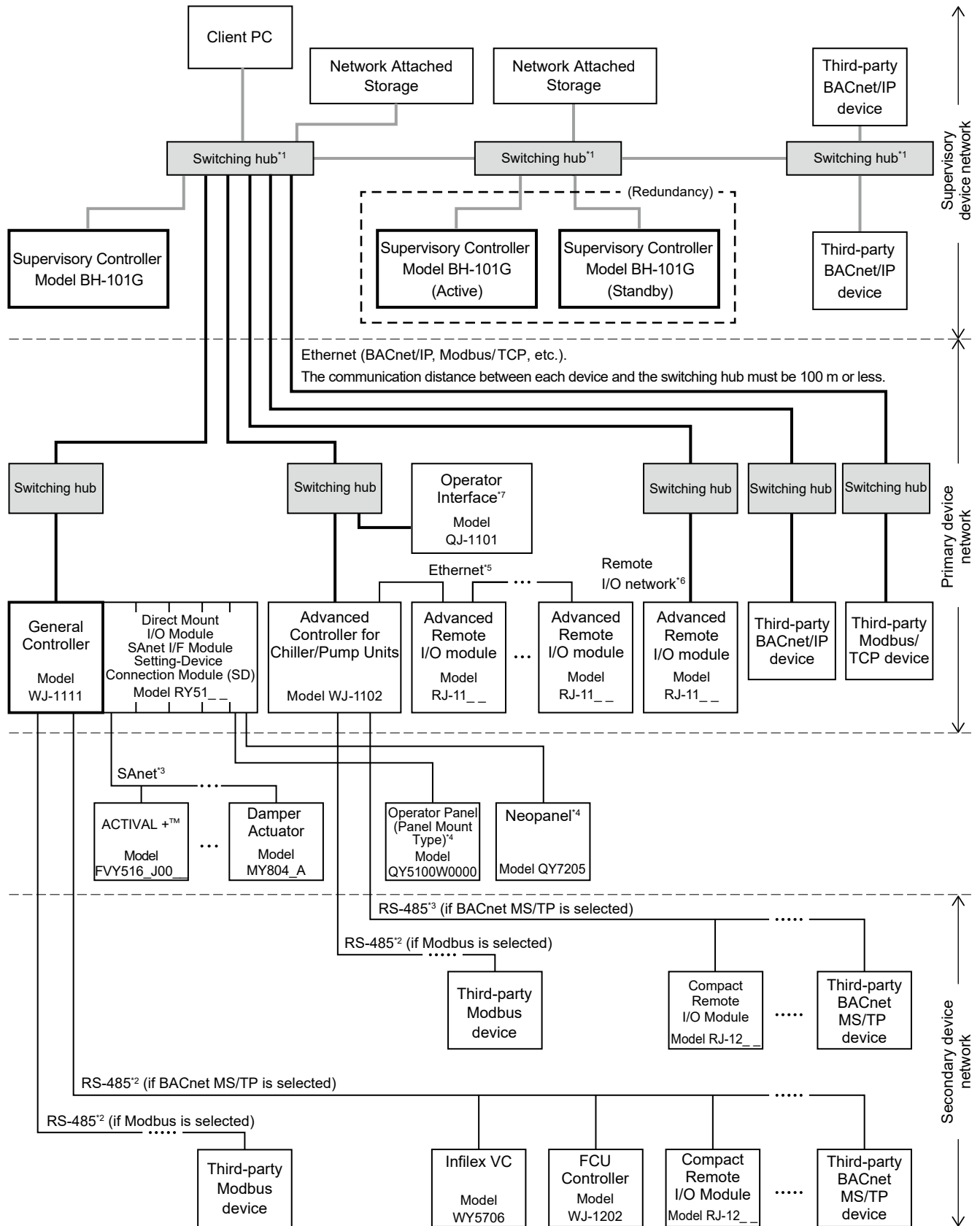



Figure 1. Example system configuration

- *1 Multiple switching hubs (network components) will be required depending on the actual equipment placement. When the switching hub is compatible with SNMP, the SVC can monitor information such as port link up/down.
- *2 The General Controller, Advanced Controller for Chiller Units, and Advanced Controller for Pump Units have two channels of the RS-485 line.
 For each channel, communication protocol can be selected from BACnet MS/TP, Modbus™ RTU, or Modbus™ ASCII.
 - The number of devices that can be connected for BACnet MS/TP
If only the Azbil devices are connected:
 50 devices/channel (VAV/FCU Controllers, Compact Remote I/O Modules, etc.)
 There are restrictions on the General Controller that up to 70 secondary devices or up to 50 of the sum of Azbil's VAV and FCU controllers can be connected. There are no restrictions on the Advanced Controller for Chiller Units, and Advanced Controller for Pump Units.
If only the third-party devices are connected:
 31 devices/channel (when transmission speed is 76.8 kbps, 30 objects/device)
 - The number of devices that can be connected for Modbus
 31 devices/channel (when transmission speed is 76.8 kbps, 30 objects/device)

If the transmission speed and the number of objects are different among the third-party devices, or if the Azbil devices and third-party devices coexist on the same channel, the number of connected devices will vary. For details, please contact one of Azbil salespersons.
- *3 By connecting the SAnet Interface Module, it is possible to connect the Intelligent Component Series devices.
 For restrictions on the SAnet communication line, refer to AB-6713, *Intelligent Component Series for SAnet Communication Installation Manual*.
- *4 By connecting the Setting-Device Connection Module (SD), you can connect the Operator Panel (Panel Mount Type), and Neopanel, Neoplate.
 By connecting the Operator Panel (Integral Type), you can connect Neopanel, and Neoplate devices.
 AB-7530, *Operator Panel (Panel Mount Type), Operator Panel (Integral Type) Specifications/Instructions*
- *5 A network that connects the Advanced Controller for Chiller Units, Advanced Controller for Pump Units and Advanced Remote I/O Modules under their control is referred to as a local I/O network.
 A switching hub is not required for the local I/O network since a jumper wiring using ETHERNET is used between the Advanced Controller for Chiller Units, and Advanced Controller for Pump Units of the local I/O network and the high speed remote I/O module under their control and between the Advanced Remote I/O Module and the I/O module.
- *6 A network that connects the Advanced Controller for Chiller Units, Advanced Controller for Pump Units, and Advanced Remote I/O Modules through a host network is referred to as a remote I/O network.
 A switching hub is required to connect the Advanced Remote I/O Modules to the remote I/O network.
 The number of Advanced Remote I/O Modules that can be connected to this network should be up to three units per Advanced Controller for Chiller Units, or Advanced Controller for Pump Units.
 When using IPv6 for BACnet communication, the Advanced Remote I/O Module cannot be connected via a remote I/O network.
- *7 Up to four Controllers (Model WJ-1102) can be managed with one Operator Interface (Model QJ-1101) unit.

■ Model Numbers

Model number	Description
BH-101G0W0000-U	Supervisory Controller
BH-101G0N0000-U	Supervisory Controller without azbil logo

● Items Provided Separately

Model number	Description
83104567-001	DIN rail clamp

● Replacement Parts

Model number	Description	Replacement interval
83173710-001	Fan replacement kit	Only in the case of failure.
83173707-001	Power connector (× 1)	
83173883-001	I/O plug (DI connector × 2, DO connector × 1)	
83170639-001	Lithium battery (× 1)	Five years (For the first time, five years from the date of manufacture of this product)
83170639-005	Lithium battery (× 5)	
83170639-010	Lithium battery (× 10)	

■ Specifications

● Basic Specifications

Item		Specification	
Power supply specifications	Rated voltage	100–240 V AC, 50 Hz/60 Hz	
	Operating power supply voltage	90–264 V AC, 50 Hz/60 Hz ± 3 Hz	
	Inrush current	50 A max. (240 V AC)	
	Power consumption	60 VA max. (240 V AC)	
	Leakage current	1.5 mA max. (240 V AC)	
Backup power	For system	Lithium ion capacitor module	
	For RTC	Lithium battery (non-chargeable)	
CPU	Intel® Atom E3845	1.9 GHz, 4 cores, 4 threads, 64 bits	
Main storage capacity	DDR3L SDRAM	2 GB	
Auxiliary storage device	SATA SSD	32 GB	
Commu- nications	Ethernet	Number of lines	1
		Communication speed	100/1000 Mbps
		Communication method	Auto negotiation, Auto MDI/MDI-X
Material and color of main parts	Case, base, cover, fan cover	Modified PPE, black	
	Door	Modified PPE, silver	
	Fan bracket	Hot-dipped steel plate (1 mm thick)	
	Lens	Polycarbonate, transparent	
	DIN holder	Polyacetal, black	
	Key top	Aluminum alloy (Al+Mg)	
	Panel	Polycarbonate board, 2 mm thick, transparent	
Anti-static sheet	Polycarbonate board, 0.1 mm, black		
Weight		1.4 kg	
Environmental conditions	Rated operating conditions	Ambient temperature	5–40 °C
		Ambient humidity	30–85 % RH (without condensation)
		Altitude	2000 m max.
		Vibration	3.2 m/s ² max. (10–150 Hz)
	Transport and storage conditions	Ambient temperature	-20–60 °C
		Ambient humidity	30–85 % RH (without condensation)
	Vibration	4.9 m/s ² max. (10–150 Hz)	

CPU: central processing unit

DDR3L: double data rate type three low voltage

DIN: Deutsches Institut für Normung (German Institute for Standardization)

MDI: medium dependent interface

MDI-X: medium dependent interface crossover

PPE: polyphenylene ether

RTC: real-time clock

SATA: serial ATA

SDRAM: synchronous dynamic random-access memory

SSD: solid-state drive.

● Specifications for Inputs and Outputs

Item		Specification	
Digital input	Number of input terminals	8	
	Voltage	12 V DC -10/+15 % (with voltage contact)	
	Current	10 mA DC typ.	
	Connected device output method	Dry contact or open collector	
Digital output	Number of output terminals	2	
	Relay output	Output method	Photo MOS relay
		Rated contact voltage	12 V DC, 100 mA DC max.

■ Specifications for Wiring

Item	Wire type	Maximum cable length	Remarks
Power supply	600 V PVC-insulated cable (IEC 60227-3)/ CVV equivalent, stranded cable, 1.25–2.0 mm ² Daisy chain supported (only for cables with the same cross-sectional area of 1.5 mm ²)	–	
Ground	600 V PVC-insulated cable (IEC 60227-3)/ CVV equivalent, stranded cable, 1.25–2.0 mm ² Daisy chain supported (only for cables with the same cross-sectional area of 1.5 mm ²)	–	Ground the product with resistance less than 100 Ω.
Ethernet	Twisted pair cable, category 5e	100 m	1000BASE-T cable as defined in ISO/IEC8802-3, or equivalent
Direct input	600 V PVC-insulated cable (IEC 60227-3)/ CVV equivalent, stranded cable, 0.5–1.25 mm ²	350 m	
Direct output	600 V PVC-insulated cable (IEC 60227-3)/ CVV equivalent, stranded cable, 0.5–1.25 mm ²	350 m	

CVV: control-use vinyl insulated vinyl sheathed cable

External Dimensions

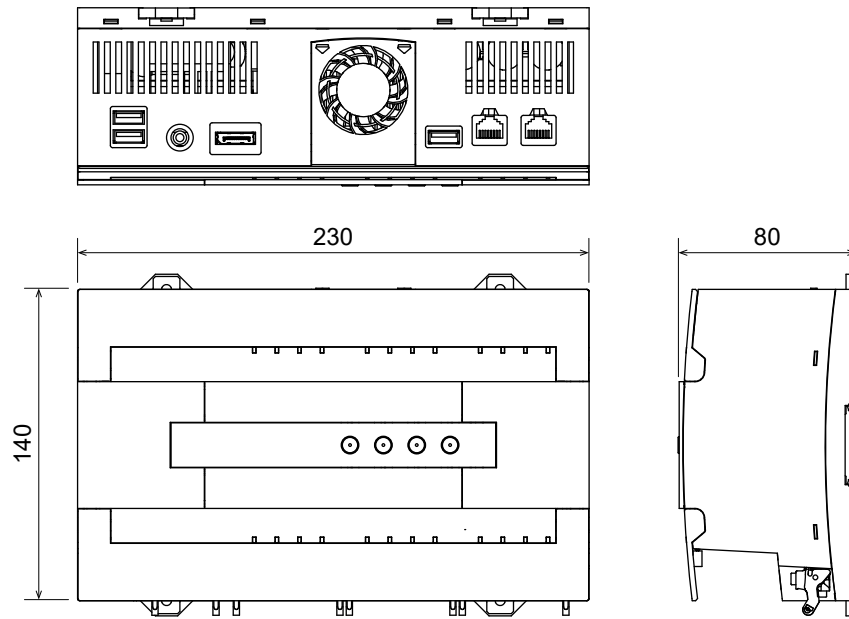

Figure 2. External dimensions (mm)

Name of Parts

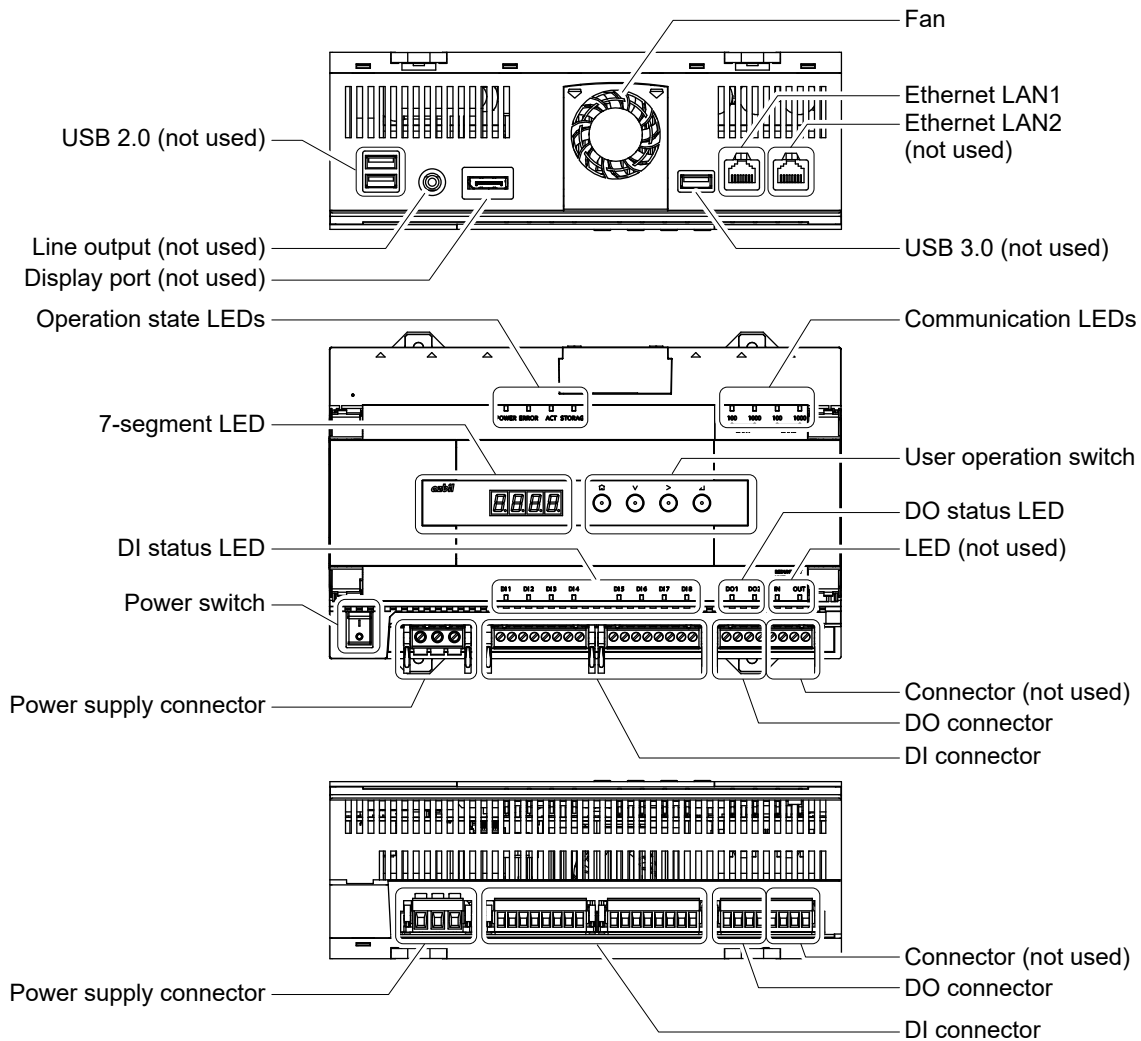





Figure 3. Name of parts

■ Installation

⚠ WARNING	
	Install this product in a location out of reach of unauthorized people. (e.g. Inside of the control panel with a lock) Failure to do so might cause electric shock.

⚠ CAUTION	
	Do not drop this product. Doing so may cause an injury or may damage the device.
	Install, wire, and use this product under the conditions specified by this manual. Failure to do so may cause fire or device failure.
	Installation and wiring must be performed by personnel qualified to do instrumentation and electrical work. Mistakes in installation or wiring may cause fire or electric shock.

● Installation Location

This product must be installed in a control panel cabinet.

Note: A unit that satisfies the following conditions is considered to be equivalent to a control panel.

Flame resistance: V-1 or higher (UL 94 standard)

Strength: Enclosure stiffness test (EN 61010-1:2010 8.2)

The control panel should be installed in a place that satisfies the following:

- An indoor place that is not exposed to direct sunlight
- A place that is not near water

Note: The product is not waterproof.

● Installation Angle

- This product should be installed upright in the control panel.

Installation of this product on a slant or laid on its side is prohibited. Doing so reduces heat radiation performance, which may cause the internal temperature to rise abnormally.

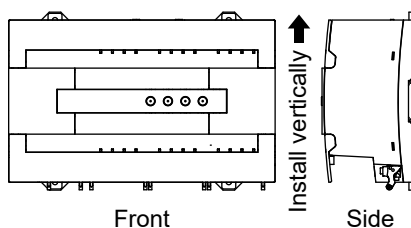

Figure 4. Installation angle

- Do not block the ventilation holes by putting an object on top of the product, etc.

● Installation Method

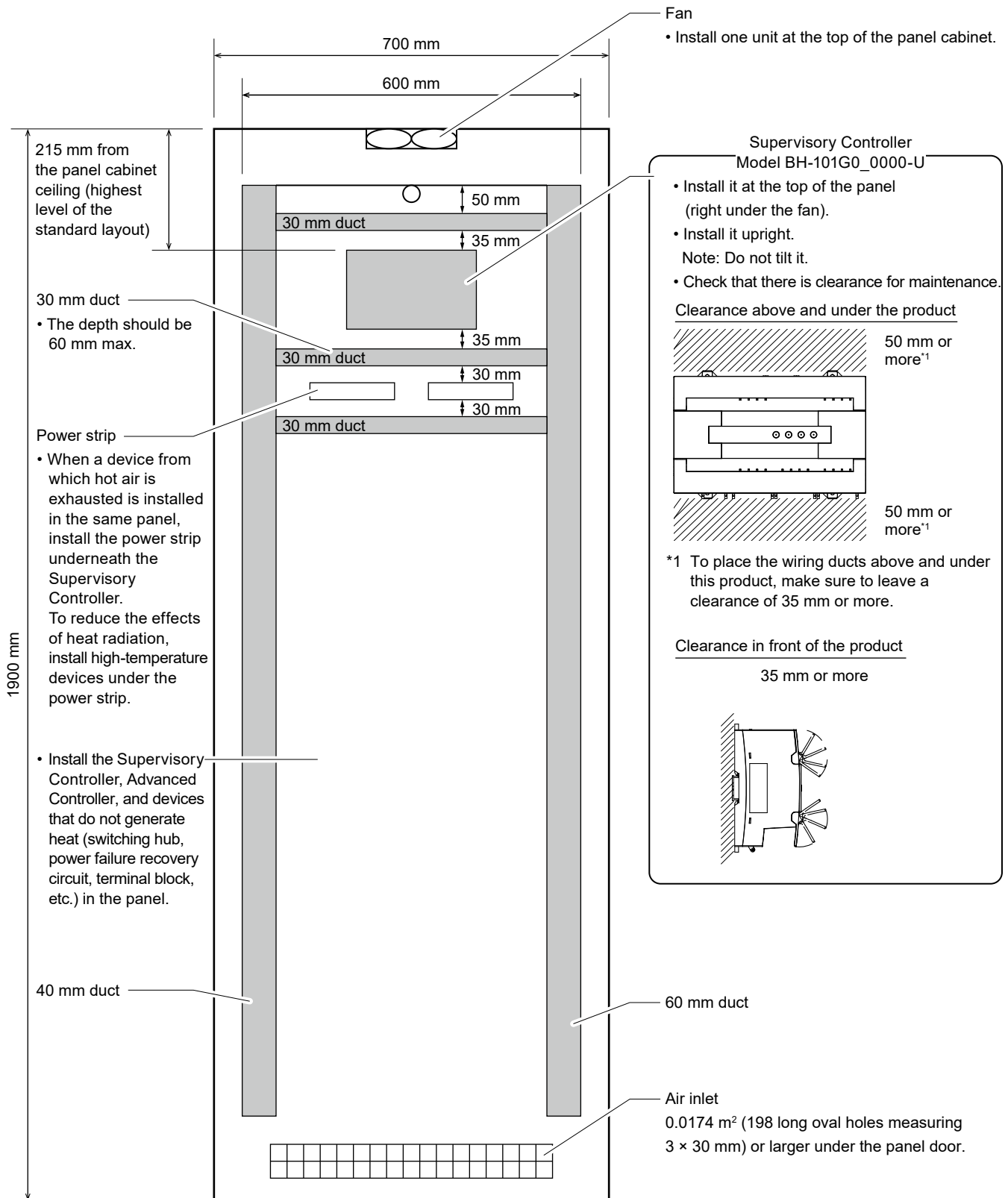
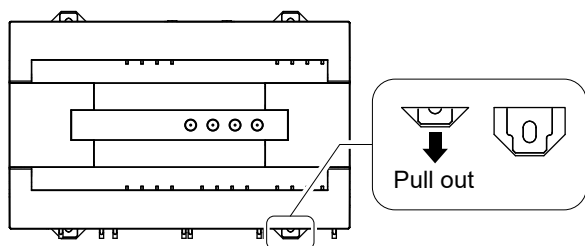

Figure 5. Example of installation in control panel cabinet

<Installation on a DIN Rail>

- (1) Pull down the two DIN holders on the bottom of the device.



- (2) Hook the upper part of the DIN holder to the DIN rail and check that it is hooked securely.

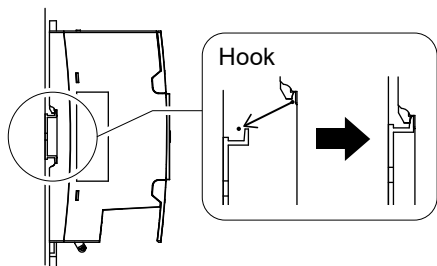

- (3) Push up the two DIN holders on the bottom of the device.

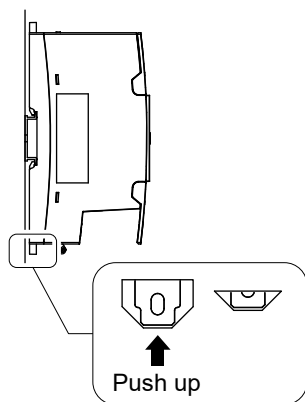

- (4) Check that the four DIN holders on the top and bottom of the device are secured on the DIN rail. Check that the device is steady.
- (5) Secure both ends with the DIN rail clamps (Model 83104567-001).
After installation, keep the connectors that come with the device because they will be used for wiring connection.

<Direct Installation with Screws>

Install the product on the wall or panel wall using four M4 L=8 screws or four studs with female threads.

- (1) Make four screw holes in the installation locations.

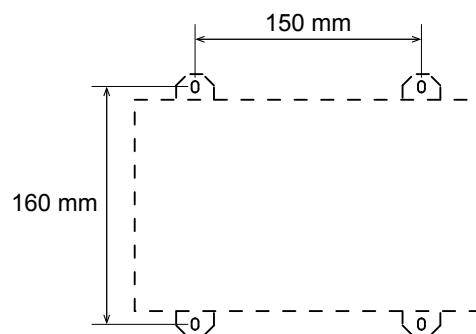

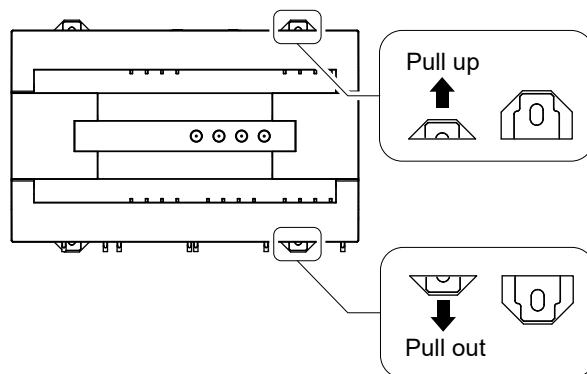

- (2) Pull up the two DIN holders at the top of the device and then pull down the two DIN holders on the bottom.



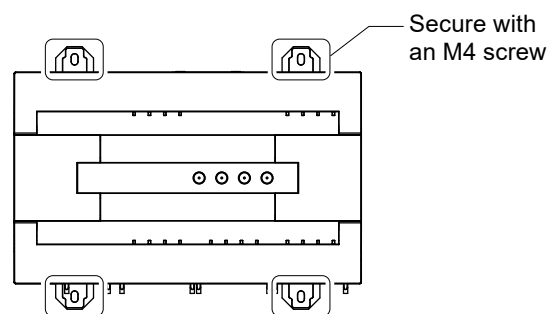





- (3) Use the four holes for the DIN holder to secure the device with the M4 screws. Check that the device is steady.



■ Wiring

⚠ WARNING	
	Be sure to ground the product with ground resistance of less than 100 Ω. Improper grounding may cause electric shock or malfunction.
	Before wiring or maintenance, be sure to turn off the power to this product. Failure to do so may result in electric shock or device failure.

⚠ CAUTION	
	Installation and wiring must be performed by personnel qualified to do instrumentation and electrical work. Mistakes in installation or wiring may cause fire or electric shock.
	All wiring must comply with applicable codes and ordinances. Otherwise there is a danger of fire.
	Take anti-noise measures if this product is installed in a location near source of electric noise. Failure to do so may cause malfunction or device failure.
	Strip the insulation from cables as specified in this manual. If the length of exposed wire is longer than specified, it may cause electric shock or short circuit between adjacent terminals. If it is too short, it may not make proper contact.
	Tighten the terminal screws with the specified torque. Insufficient tightening of the terminal screws may cause fire or overheating.
	Do not use unused/spare terminals on this product as relay terminals. Doing so may cause device failure.

● Notes on Wiring

- Do not use an uninterruptible power supply that outputs rectangular waves. Doing so may cause the device to fail.
- Use cable ties so that cables will not hide the LEDs and switches.
- Do not let the wiring between the cable duct and the device hang loose.

● Wiring of Power Supply Terminal Block

Screw connectors are used.

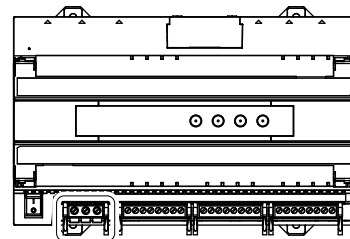

Power supply connector

- (1) Strip 7 mm of insulation from the cable core wire.

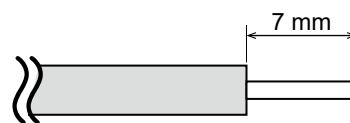

- (2) If the connector is plugged into the device, push in the release levers on the right and left sides of the connector to remove it from the device.

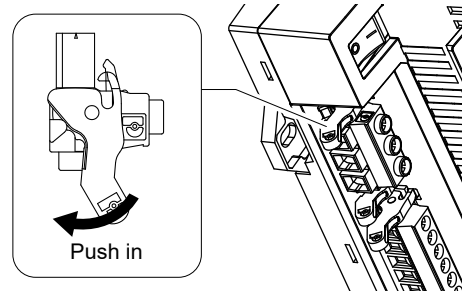

- (3) Turn the screw above the cable clamp (the hole for the cable) of the connector to the left with a screwdriver to open the cable clamp.

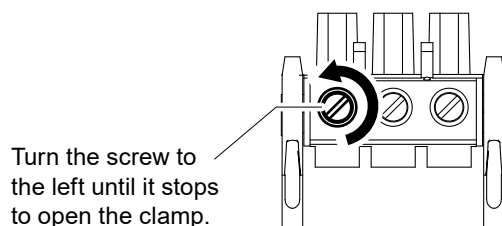

Turn the screw to the left until it stops to open the clamp.

Note: Compatible screwdriver blade: 0.6 × 3.5 mm

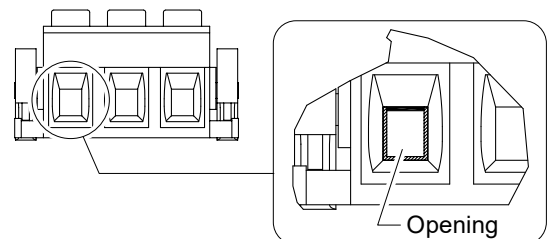

Opening

- (4) Insert the cable whose wire was exposed in step (1) into the cable clamp and tighten it by turning the screw above the cable clamp to the right with a screwdriver.

The screw tightening torque is 0.56 N·m (specified by UL as 5 lb-in).

Make sure there are no strands of cable wire protruding from the cable clamp.

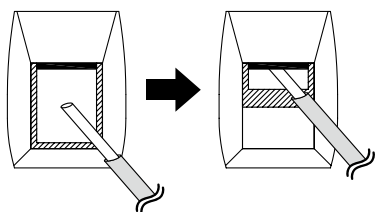

Note: Check that the cable is inserted into the cable jack.

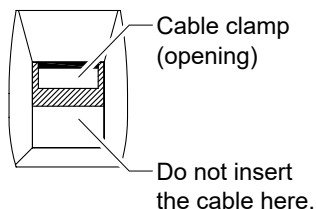

- (5) Lightly pull the cable to check that it does not come out.
- (6) Insert the connector into the device. Check that the release levers of the connector are securely locked.

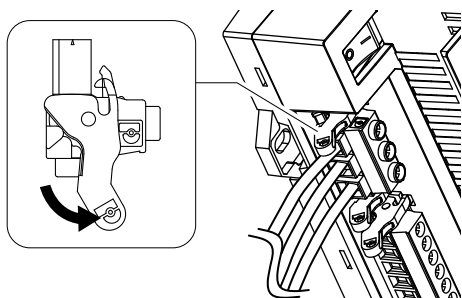

- (7) Lightly pull the cable to check that the power supply connector does not come out.

<Power Supply Terminal Block>

Terminal No.	Description
1	AC input
2	AC input
3	Ground

● Wiring of the Direct Input Terminal Blocks and Direct Output Terminal Block

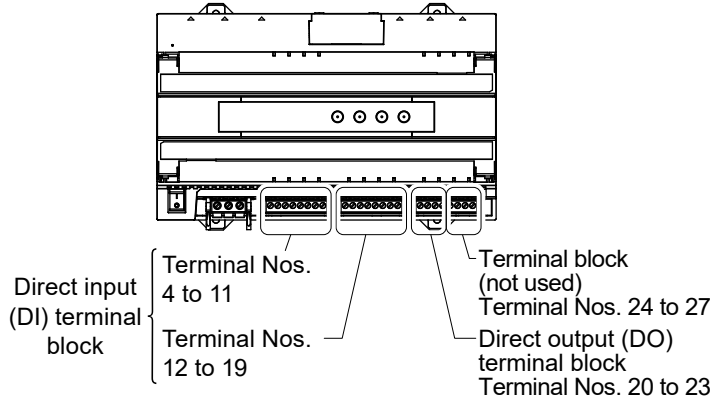

- (1) Strip 7 mm of insulation from the cable core wire.
- (2) If the connector is plugged into the device, push in the release levers on the right and left sides of the connector to remove it from the device.

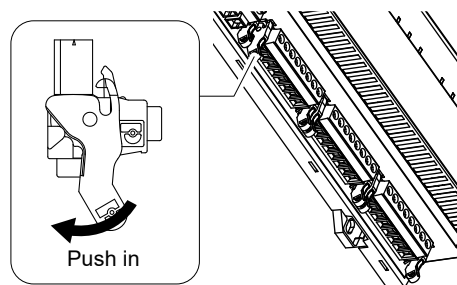

- (3) Turn the screw above the cable clamp (the hole for the cable) of the connector to the left with a screwdriver to open the cable clamp.
- (4) Insert the cable whose wire was stripped in step (1) into the cable clamp and tighten it by turning the screw above the cable clamp to the right with a screwdriver. The screw tightening torque is 0.56 N·m (specified by UL as 5 lb-in). Make sure there are no strands of cable wire protruding from the cable clamp.
- (5) Lightly pull the cable to check that it does not come out.
- (6) Insert the connector into the device. Check that the release levers of the connector are securely locked.

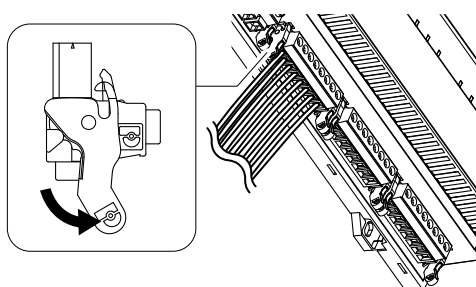

- (7) Lightly pull the cable to check that the power supply connector does not come out.

<Direct Input Terminal Blocks>

Terminal No.	Connector Pin No.	Description (example usage)
4	1	DI CH1 (fire inputs)
5	2	DI CH1 common
6	3	DI CH2 (generator switching input)
7	4	DI CH2 common
8	5	DI CH3 (power supply status input)
9	6	DI CH3 common
10	7	DI CH4 (reset alarm output)
11	8	DI CH4 common
12	9	DI CH5 (reserved)
13	10	DI CH5 common
14	11	DI CH6 (reserved)
15	12	DI CH6 common
16	13	DI CH7 (reserved)
17	14	DI CH7 common
18	15	DI CH8 (reserved)
19	16	DI CH8 common

<Direct Output Terminal Block>

Terminal No.	Connector Pin No.	Description (example usage)
20	1	DO CH1 (point alarm)
21	2	DO CH1 common
22	3	DO CH2 (device alarm)
23	4	DO CH2 common
24	5	Not used
25	6	Not used
26	7	Not used
27	8	Not used

● Wiring for Ethernet

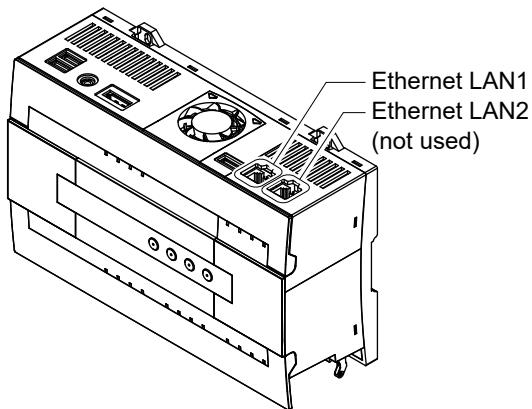

Figure 6

■ Handling

Do the following before turning the power on.

- (1) Check again that the wiring is done correctly.
- (2) Peel off the protective sheets before powering the device on.

Note: Check that all protective sheets have been peeled off.

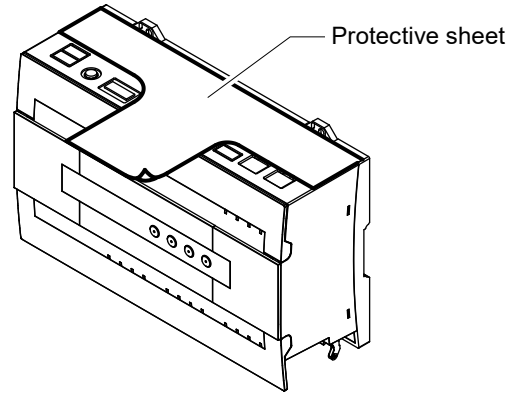

	CAUTION
	Do not block the ventilation holes of this product. Doing so may cause device failure.

■ Device Protection after Installation

After this product is installed, if installation of other equipment is ongoing nearby (etc.), take dust-proofing measures for the product to prevent metal shavings, dust, and other particles from entering the product.

Note: Take dust-proofing measures for the product regardless of whether the protective sheets are still attached to the product.

■ Power On/Off

⚠ WARNING



Do not touch electrically charged parts.
Doing so may cause electric shock.

IMPORTANT!!

- Do not test the withstand voltage of this product. Doing so may cause the device to fail.
- If more than the rated power voltage is applied to this product, replace the product with a new one. Failure to do so may result in a malfunction.

In order to retain the minimum required system data, the product has an on-board lithium ion capacitor module.

When no power is supplied due to power failure or power shutoff, the lithium ion capacitor module supplies power for one second (by default) to maintain functions excluding direct inputs/outputs as a countermeasure against instantaneous power failure. It then continues supplying power until the status data stored in the memory is transferred to the secondary storage medium (SSD) as part of the shutdown process.

When power is supplied from the main power supply due to restoration of power or power-on operation, the module is charged automatically.

- Charge the lithium ion capacitor module by turning on the power for the product within six months of its delivery. Turning on the power charges the capacitor automatically. A continuous charge duration of five minutes or less is required for a full charge.
- If a fully charged lithium ion capacitor module has been off for six months or more, it will have fallen below the discharge stop voltage (6.9 V). Charging the module in this state significantly reduces the part life. Therefore, if an excessively discharged state is detected, this product stops charging the lithium ion capacitor module for the sake of safety. The lithium ion capacitor module will no longer be able to be charged. If the POWER LED does not stop flashing and stays on for 10 minutes after turning the power on when the controller is already charged, the controller itself must be replaced.
- Do not turn the power on/off frequently. After it is turned on, wait at least 5 minutes before turning it off.
- If the SVC will not be turned on again for one month or longer, turn it off in shutdown mode. When you turn off the power switch on the SVC, the SVC shuts down using the lithium ion capacitor module. Therefore, you cannot turn off the power when the lithium ion capacitor is fully charged. The life of the lithium ion capacitor module may be reduced because it discharges by itself even while it is not in use.

● Turning OFF the SVC

- Press the [➤] button (one of the user operation switches) three times at intervals of less than 1 second. The shutdown mode will be activated and "P_{OFF}" will be displayed.
Note: If the interval is 1 second or longer, the mode will return to automatic mode.
- Press the [ENTER] button. When the shutdown process is complete, "8888" will be displayed. The LEDs and system indicators will be turned off.
Note:
 - Pressing any button except [ENTER] will return the unit to automatic mode. Also, if no button is pressed for 5 seconds or longer, automatic mode will resume.
 - "P_{OFF}" will flash every second while shutdown is in process.
- Turn off the power to the SVC.

■ Indicators

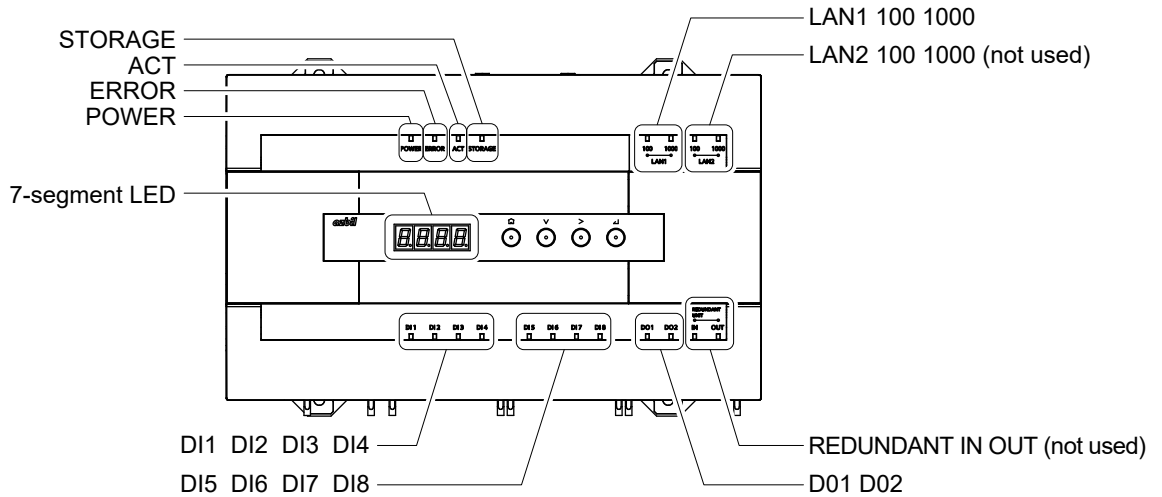







Figure 7. Indicator positions

Item	Product indicator	Color	State	Description
Power indicator	POWER	Green	Lit	Power ON
			Flashing	Power ON (Lithium ion capacitor module being charged)
			Not lit	Power OFF
System error indicator	ERROR	Red	Lit	Abnormal
			Flashing	Note: Contact Azbil Corporation.
			Not lit	Normal
Active indicator for redundant product configuration	ACT	Green	Lit	The device is operating (active).
			Not lit	The device is for backup (standby).
Storage access indicator	STORAGE	Green	Lit	The data storage is being accessed.
			Not lit	The data storage is not being accessed.
Ethernet communication indicator	LAN1 100 LAN2 100 (not used)	Green	Lit	A link is established at 100 Mbps.
			Flashing	Data is being received or transmitted at 100 Mbps.
			Not lit	A link has not been established.
	LAN1 1000 LAN2 1000 (not used)	Green	Lit	A link is established at 1000 Mbps.
			Flashing	Data is being received or transmitted at 1000 Mbps.
			Not lit	A link has not been established.
System indicator	Indication using 7-segment LED	Blue	Normal	The four 7-segment LEDs are lit in sequence at their outer edges at an interval of two seconds.
			Abnormal	Indication other than above.
DI status indicator	DI ch1–ch8	Green	Lit	DI status is ON.
			Not lit	DI status is OFF.
DO status indicator	DO ch1 and ch2	Green	Lit	DO status is ON.
			Not lit	DO status is OFF.
Indicator (not used)	IN	–		
	OUT	–		

■ Maintenance

 WARNING	
	Do not touch electrically charged parts. Doing so may cause electric shock.

 CAUTION	
	Do not disassemble this product. Doing so may cause device failure.
	Before cleaning the product or retorquing the terminal screws, be sure to turn off the power to the product. Failure to do so may cause electric shock, device failure, or malfunction.

Azbil Corporation personnel who have been trained on the product will carry out periodic maintenance and parts replacement.

Please contact us.

Note: Refer to the "Model Numbers" section for details on replacement parts.

● Notes for Daily Care

- Keep the temperature and humidity environment within system specifications.
Otherwise, the product life will be affected.
- Keep the area around the system clean.
Otherwise, the life of the fan and other parts will be affected.
- Do not put devices or other items that cause vibrations or impact near this system.
Doing so may result in loose electrical connections.
- Do not eat or drink around the system.
Doing so may result in spilled liquid or other unexpected accident.

● Inspection

<Items to Inspect>

Inspect the device for the following problems.

- The product generates abnormal noise.
- The product gives off an unusual odor.
- The fan is not rotating and air is not coming out of the exhaust vent.
- Dust has built up on the inlet and exhaust vents around the device.
- A connector has fallen off of the product.
- The display is hard to read.

<Inspection Procedure>

- If the product generates abnormal noise, the fan may have failed.
Clean the fan according to "● How to Clean <How to Clean Built-up Dust>."
If this does not solve the problem, contact Azbil Corporation.
- If the product has an unusual odor, possible causes are dust buildup and failure of internal parts.
Please contact Azbil Corporation.
- If you do not feel air when you put your hand near the fan, the fan has failed.
Please contact Azbil Corporation.
- If there is dust buildup, clean the fan according to "● How to Clean <How to Clean Built-up Dust>."
- If connectors have fallen off of the product, reconnect them.
- If the display is hard to read, clean the device according to "● How to Clean <How to Clean the Display>."

● Notes on Cleaning

- Clean the device according to this manual.
Do not touch the parts and switches not mentioned in this manual.
Doing so may cause an electric shock or system shutdown.

● How to Clean

<How to Clean Built-up Dust>

Dust buildup on the fan may cause it to fail, and as a result, the product may not function normally.

Therefore, clean around the device every three months.

- Vacuum dust around the device using a small vacuum cleaner or other tool.
- If the fan generates abnormal noise, remove the fan assembly and vacuum the dust attached to the blades using a small vacuum cleaner or other tool.

<How to Clean the Display>

- Clean the surface of the device with cleaner for office equipment.
Do not use cleaners that contain alcohol, thinner or similar substances.
- Use the cleaner according to its specified uses and notes on handling.

● **How to Remove and Attach the Fan Assembly**

Remove the fan while this product is operating.

⚠ CAUTION	
!	<p>Before touching this product, be sure to remove any static electrical charge from your body. Otherwise your static electricity may damage some components of the product. Static electrical charge can be removed by touching the grounded metal.</p>
	<p>When removing the fan, be sure not to insert fingers into the product. Doing so may damage the internal components.</p>

- (1) Open the door at the top of the device.

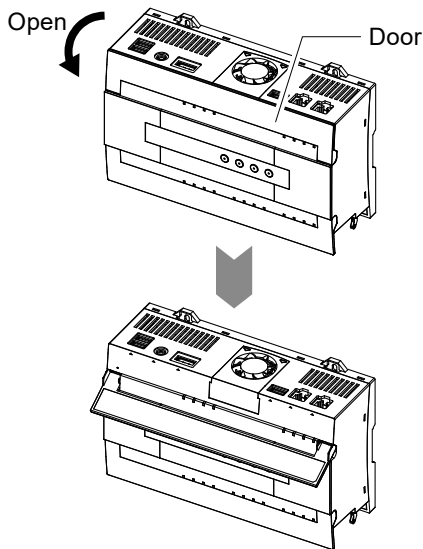

- (2) Remove the fan cover.
Pull the fan cover toward you while pressing down on the two triangles on the top of the fan cover.

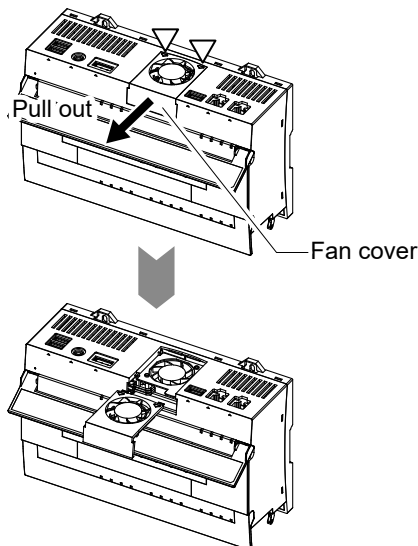

- (3) Pull the connector out of the fan assembly.

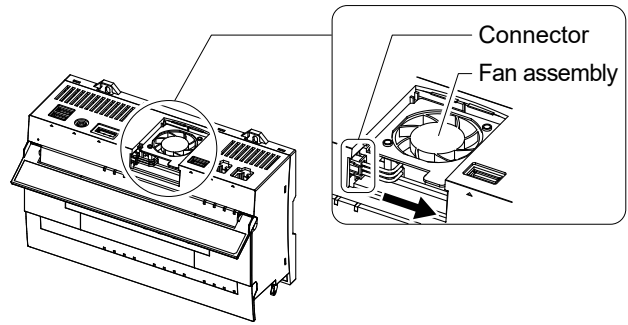

- (4) Check that the fan has stopped.
(5) Lift and remove the fan assembly.

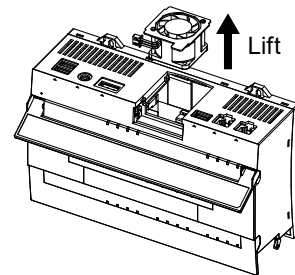

- (6) Clean the fan assembly using a small vacuum cleaner or other tool.
(7) Attach the fan assembly by performing the operation described in step (5) in reverse.
(8) Connect the fan assembly connector.
(9) Place the fan cover over the fan and push it in until it is in place.
(10) Close the door at the top front of the device.
(11) Check that air is vented from the fan cover and that the fan does not generate abnormal noise.

● Replacement Procedure

<Clock Battery (Lithium Battery)>

Handling precautions

- Replace the clock battery while the device is turned on (if the battery is removed while the device is turned off, time data will be lost.).
- Discharge static electricity before touching the product.

- (1) Remove the cover on the right side of the device. Insert a fingernail into the gap in the cover and pull out the cover.

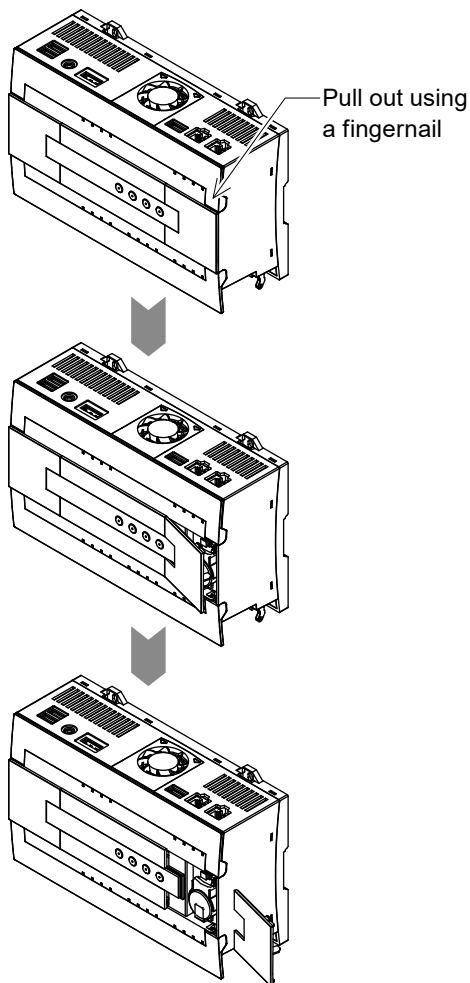

- (2) Remove the wiring cable from the clamp.
 (3) Disconnect the wiring cable connector from the clock battery.
 (4) Remove the clock battery.

- (5) Insert a new clock battery in the same place as the original one.

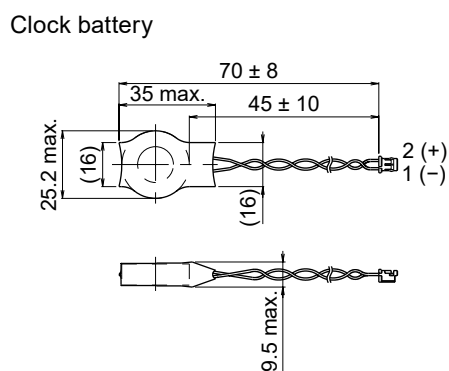
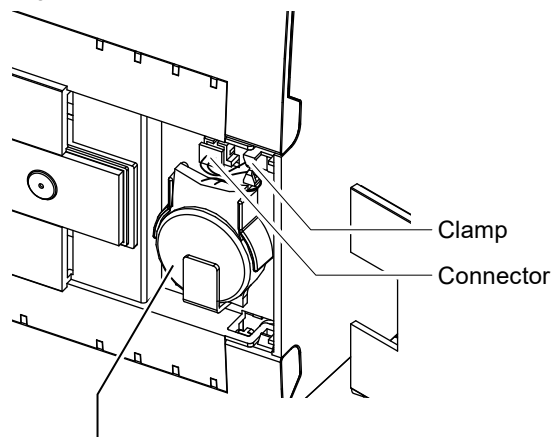

Nominal voltage	3 V
Operating temperature range	-40–80 °C

- (6) Reconnect the wiring cable connector in its original position.
 (7) Put the wiring cable into the clamp as it was originally.
 (8) Replace the cover removed in step (1).

■ Disposal

⚠ CAUTION	
!	Dispose of used lithium batteries in accordance with local regulations. Do not throw them in the fire or dispose of them with ordinary garbage.
	Doing so may cause the batteries to burst or ignite.

- Dispose of the product (including the lithium ion capacitor module) as industrial waste in accordance with your local regulations.
Do not reuse all or part of this product.



Install this product in a panel cabinet.

- PAZX ENERGY MANAGEMENT EQUIPMENT
- E492866
- UL 60730-1
- Pollution degree 2
- OVERVOLTAGE CATEGORY II
- IP20
- TYPE 1 ACTION
- CLASS I CONTROL
- Class 2 power source
- Rated Impluse Voltage:4000V



Install this product in a panel cabinet.

Additionally, always keep the panel cabinet accessible only to people with sufficient knowledge concerning electrical equipment.

This product complies with the following harmonised standards of the Electromagnetic Compatibility Directive (EMCD) and the Low Voltage Directive (LVD).

EMCD : EN 61326-1 Class A, Table 2 (for or use in an industrial electromagnetic environment)

LVD : EN 61010-1 Overvoltage category II
Pollution degree 2

* ACTIVAL, ACTIVAL +, Infilex, and savic-net are trademarks of Azbil Corporation.

* BACnet is a trademark of American Society of Heating, Refrigerating, and Air-conditioning Engineers (ASHRAE).

* Modbus is a trademark and the property of Schneider Electric SE, its subsidiaries and affiliated companies.

Azbil Corporation
Building Systems Company



<https://www.azbil.com/>

Specifications are subject to change without notice.