

Single Loop Controller

Model R3A/R3B

Overview

Models R3A and R3B are multifunction controllers with 48 × 96 mm and 96 × 96 mm front panels, respectively.



Features

- LED display for excellent visibility
- Easy setting by [MENU], [FUNC], [ENT], and digit-change keys on the front panel.
- Input type: resistance temperature detectors (Pt100, JPt100), current signals (4–20 or 0–20 mA DC), voltage signals (0–10, –10 to +10, 0–100 mV DC or 0–1, 1–5, 0–5, 0–10, 2–10, –10 to +10 V DC).
- Control output type: relay and current.
- ON/OFF control and PID control
- Event type: 3 events (common contacts), or 2 events (independent contacts)
- CT input, digital input, RSP input, RS-485 communication, and auxiliary output can be selected by the model number specified. In addition, the pattern operation extension and asset information storage function can be added.

Safety Precautions

Please read the instructions carefully and use the product as specified in this manual.
 Be sure to keep this manual nearby for quick reference.

Restrictions on Use

This product was developed, designed, and manufactured for general air conditioning use.
 Do not use the product in a situation where human life may be at risk or for nuclear applications in radiation-controlled areas. If you wish to use the product in a radiation-controlled area, please contact Azbil Corporation.
 Particularly when the product is used in applications like the following where safety is especially required, implementation of fail-safe design, redundant design, regular maintenance, etc., should receive appropriate consideration so that the product can be used safely and reliably.

- Safety devices for protecting the human body
- Start/stop control devices for transportation machines
- Aeronautical/aerospace machines

For system design, application design, instructions for use, or product applications, please contact Azbil Corporation.
 Azbil Corporation bears no responsibility for any result, or lack of result, deriving from the customer's use of the product.

● Cautions regarding installation

Install the controller in a location that meets the following criteria:

- The common mode voltage of all I/O except for the supply power and relay contact outputs meets the following conditions:
 voltage to ground of
 30 V_{RMS} max. and 42.4 V peak max.
- Avoid high/low temperatures and humidity
- No sulfide gas or other corrosive gases
- Little dust or soot
- Protected from direct sunlight, wind, and rain
- Little mechanical vibration or shock
- Not close to high voltage lines, welding machines, or other sources of electrical noise
- At least 15 meters away from the high voltage igniter for a boiler, etc.
- Little influence from strong magnetic fields
- No flammable liquids or gases
- Indoors

■ Input/Output Configuration

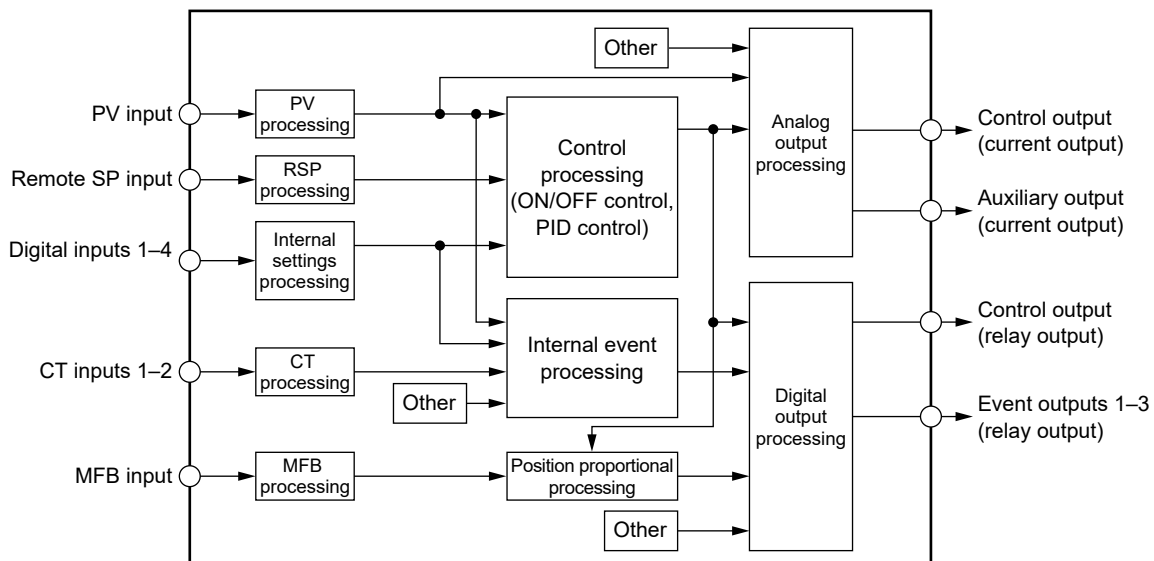

■ Model Selection

Basic model No.			Connection	Control output	Power	Options	Add'l proc.		Specifications
							1	2	
R	3	A							48 × 96 mm front panel
R	3	B							96 × 96 mm front panel
			T						Screw terminal block
				R	0				Relay output (C.O. contacts)
				R	1				Motor drive relay output
				C	0				Current output
						A			AC power supply (100–240 V AC)
							1		3 event relay outputs (common contacts)
							2		3 event relay outputs (common contacts), auxiliary output (current)
							4		2 event relay outputs (independent contacts)
							5		2 event relay outputs (independent contacts), auxiliary output (current)
							0		None
							1		4 digital inputs
							2		4 digital inputs, RS-485 communication
							3		2 digital inputs, RSP input
							4		2 digital inputs, RSP input, RS-485 communication
							0		None
							1		2 Current transformer inputs*1, *2
							0	0	None
							D	0	With inspection report
							Y	0	With traceability certificate

*1 It cannot be selected if “R1” is selected for “Control output.”

*2 Current transformer (CT) is sold separately.

● **Accessories**

Name	Qty.	Note
Mounting bracket	2	Use a mounting bracket when replacing it.
Gasket	1	Use a gasket when replacing it.

● **Optional parts (sold separately)**

Name	Model No.	Note (model No., etc.)
Terminal cover	84525948-001	For R3A
	84525949-001	For R3B
Current transformer	QN206A*1	800 turns, hole diameter 5.8 mm
	QN212A*1	800 turns, hole diameter 12 mm

*1 Not UL-certified.

● **Replacement parts**

Name	Model No.	Note
Mounting bracket	84525941-001	For R3A and R3B
Gasket	84525942-001	For R3A
	84525943-001	For R3B

■ Specifications

PV input	Number of inputs	1
	Sampling cycle	25, 50, 100, 300, or 500 ms (specifiable)
	Resistance temperature detector (RTD)	
	RTD type	Pt100 (JIS C 1604:2013) Jpt100 (JIS C 1604:1989)
	Indication accuracy (under standard conditions)	±0.1 % RD ± 1 digit (for exceptions see the PV input range table)
	Measuring current (under standard conditions)	1 mA (typical), from terminals 11 and 12
	Wiring resistance effect	±0.03 °C/Ω max.
	Allowable wiring resistance	85 Ω max.
	Operation upon input wire burnout	Table 3. Behavior if a PV Input Error Occurs
	DC voltage	
	DC voltage type	0 to 10 mV -10 to +10 mV 0 to 100 mV 0 to 1 V 1 to 5 V 0 to 5 V 0 to 10 V 2 to 10 V -10 to +10 V
	Indication accuracy (under standard conditions)	±0.1 % FS ± 1 digit (for exceptions see the PV input range table)
	Allowable input*1	±12 V (±1 V for 0–10, -10 to +10, or 0–100 mV input)
	Input impedance	1 MΩ min.
	Operation upon input wire burnout	Table 3. Behavior if a PV Input Error Occurs
	DC current	
	DC current type	0 to 20 mA 4 to 20 mA
	Indication accuracy (under standard conditions)	±0.1 % FS ± 1 digit
	Allowable input*1	25 mA max., ±12 V*2
	Input impedance	100 Ω max. (with 20 mA input)
	Operation upon input wire burnout	Table 3. Behavior if a PV Input Error Occurs

*1 A voltage or current input greater than the allowable input may damage the circuits.

*2 If a current greater than the allowable input is detected, the current path may be cut off intermittently to protect the circuit.

Table 1. RTD Input Range Types

Input type	PV input range type	Sensor type	Range	Indication accuracy	Resolution
Resistance temperature detector (RTD)	41	Pt100	-200.0 to +500.0 °C	±0.1 % RD ± 1 digit*1	0.1 °C
	42	JPt100	-200.0 to +500.0 °C	±0.1 % RD ± 1 digit*1	0.1 °C
	43	Pt100	-200.0 to +200.0 °C	±0.1 % RD ± 1 digit*1	0.1 °C
	44	JPt100	-200.0 to +200.0 °C	±0.1 % RD ± 1 digit*1	0.1 °C
	45	Pt100	-100.0 to +300.0 °C	±0.1 % RD ± 1 digit*1	0.1 °C
	46	JPt100	-100.0 to +300.0 °C	±0.1 % RD ± 1 digit*1	0.1 °C
	47	Pt100	-100.0 to +200.0 °C	±0.1 % RD ± 1 digit*1	0.1 °C
	48	JPt100	-100.0 to +200.0 °C	±0.1 % RD ± 1 digit*1	0.1 °C
	49	Pt100	-100.00 to +150.00 °C	*1	0.01 °C
	50	JPt100	-100.00 to +150.00 °C	*1	0.01 °C
	51	Pt100	-50.0 to +200.0 °C	±0.1 % RD ± 1 digit*1	0.1 °C
	52	JPt100	-50.0 to +200.0 °C	±0.1 % RD ± 1 digit*1	0.1 °C
	53	Pt100	-50.00 to +100.00 °C	±0.11 °C ± 1 digit	0.01 °C
	54	JPt100	-50.00 to +100.00 °C	±0.11 °C ± 1 digit	0.01 °C
	55	Pt100	-60.00 to +40.00 °C	±0.11 °C ± 1 digit	0.01 °C
	56	JPt100	-60.00 to +40.00 °C	±0.11 °C ± 1 digit	0.01 °C
	57	Pt100	-40.00 to +60.00 °C	±0.11 °C ± 1 digit	0.01 °C
	58	JPt100	-40.00 to +60.00 °C	±0.11 °C ± 1 digit	0.01 °C
	59	Pt100	-10.00 to +60.00 °C	±0.11 °C ± 1 digit	0.01 °C
	60	JPt100	-10.00 to +60.00 °C	±0.11 °C ± 1 digit	0.01 °C
	61	Pt100	0.00 to 100.00 °C	±0.11 °C ± 1 digit	0.01 °C
	62	JPt100	0.00 to 100.00 °C	±0.11 °C ± 1 digit	0.01 °C
	63	Pt100	0.0 to 200.0 °C	±0.1 % RD ± 1 digit*1	0.1 °C
	64	JPt100	0.0 to 200.0 °C	±0.1 % RD ± 1 digit*1	0.1 °C
	65	Pt100	0.0 to 300.0 °C	±0.1 % RD ± 1 digit*1	0.1 °C
	66	JPt100	0.0 to 300.0 °C	±0.1 % RD ± 1 digit*1	0.1 °C
	67	Pt100	0.0 to 500.0 °C	±0.1 % RD ± 1 digit*1	0.1 °C
	68	JPt100	0.0 to 500.0 °C	±0.1 % RD ± 1 digit*1	0.1 °C
	69	Pt100	-200.0 to +850.0 °C	±0.1 % RD ± 1 digit*1	0.1 °C
	70	JPt100	-200.0 to +640.0 °C	±0.1 % RD ± 1 digit*1	0.1 °C

*1 below 200 °C, ±0.15 °C ± 1 digit

Input sensor standards Pt100 : JIS C 1604:2013

JPt100 : JIS C 1604:1989

Table 2. Linear Input Range Types

Input type	PV input range type	Sensor type	Range	Indication accuracy	Resolution
Linear mV	81	DC voltage	0 to 10 mV	±0.2 % FS ± 1 digit	It varies depending on the PV decimal point position setting. -19999 to +19999 -1999.9 to +1999.9 -199.99 to +199.99 -19.999 to +19.999
	82	DC voltage	-10 to +10 mV	±0.1 % FS ± 1 digit	
	83	DC voltage	0 to 100 mV	±0.1 % FS ± 1 digit	
Linear V	84	DC voltage	0 to 1 V	±0.1 % FS ± 1 digit	
	86	DC voltage	1 to 5 V	±0.1 % FS ± 1 digit	
	87	DC voltage	0 to 5 V	±0.1 % FS ± 1 digit	
	88	DC voltage	0 to 10 V	±0.1 % FS ± 1 digit	
	91	DC voltage	2 to 10 V	±0.1 % FS ± 1 digit	
	92	DC voltage	-10 to +10 V	±0.1 % FS ± 1 digit	
Linear mA	89	DC current	0 to 20 mA	±0.1 % FS ± 1 digit	
	90	DC current	4 to 20 mA	±0.1 % FS ± 1 digit	

Digital input (option)	Number of inputs	2 or 4
	Input type	Non-voltage contacts or open collector (sink type)
	Allowable ON contact resistance	250 Ω max.
	Allowable OFF contact resistance	100 k Ω min.
	Allowable ON residual voltage	1.0 V max.
	Terminal current while ON	Approx. 7.5 mA (when shorted) / approx. 5.0 mA (at a contact resistance of 250 Ω)
	Minimum hold time	Sampling cycle + 10 ms
	Open terminal voltage	5.5 V DC \pm 1 V
	Parallel connection circuit voltage	24 V DC max.
Current transformer input (option)	Number of inputs	2 or 1
	Input object	Current transformer with 100–6000 turns
	Indication accuracy (under standard conditions)	\pm 2.5 % FS \pm 1 digit (not including accuracy of current transformer in the case of sine waves)
	Current transformer input	
	Measurement current	1.0–100.0 A AC, 50/60 Hz (800 turns, 1 pass of the power wire)
	Allowable measured current	0.0–110.0 A AC, peak current: 155.0 A (800 turns, 1 pass of the power wire)
	Allowable input	150 mA and 212 mA peak (AC) max. 1.0 V and 1.4 V peak (AC) max.
	Transient overvoltage	Supply voltage + 250 V
Indication resolution	0.1 A	
Remote SP input (option)	DC voltage type	0 to 1 V, 1 to 5 V, 0 to 5 V, 0 to 10 V, 2 to 10 V, -10 to +10 V
	DC current type	0 to 20 mA, 4 to 20 mA
	Allowable input (DC voltage)*1	\pm 12 V
	Allowable input (DC current)*2	25 mA max., \pm 12 V*2
Motor feedback input (MFB) (option)	Input type	Potentiometer resistance
	Resistance range	100 to 2500 Ω
	Indication accuracy (under standard conditions)	\pm 0.5 % FS \pm 1 digit
	Input update range	100 ms
Control output (select by model number)	Relay output	
	Contact configuration	1c (SPDT)
	Contact rating	250 V AC / 30 V DC, 3 A (resistive load)
	Service life	N.O.: 100,000 cycles or more N.C.: 100,000 cycles or more
	Minimum switching specifications (reference value)	5 V, 100 mA
	Minimum switching specifications (close time)	50 ms
	Current output	
	Output type	0–20 mA DC or 4–20 mA DC
	Allowable load resistance	600 Ω max.
	Output accuracy (under standard conditions)	\pm 0.1 % FS
	Output resolution	1/12500 (at 0–20 mA DC), 1/10000 (at 4–20 mA DC)
	Output update cycle	Same as sampling cycle
	Motor drive relay output	
	Contact configuration	2 circuits Switching between OPEN output and CLOSE output (with function for turning both outputs OFF at the same time)
	Contact rating	250 V AC, 6 A (resistive load); 250 V AC, 2 A ($\cos\phi = 0.4$); 24 V DC, 2.5 A (L/R = 0.7 ms)
	Service life	120,000 cycles or more (at the rated resistive load) 100,000 cycles or more (at the rated inductive load)

*1 A voltage or current input greater than the allowable input may damage the circuits.

*2 If a current greater than the allowable input is detected, the current path may be cut off intermittently to protect the circuit.

Event	Number of outputs	2 to 3 (depending on the model.)			
	Available internal events	Up to eight events			
	Event types	<ul style="list-style-type: none"> ●: ON/OFF changes at the value ○: ON/OFF changes when the value is exceeded by 1 U. 			
		PV high limit		PV low limit	
	Direct action	Reverse action	Direct action	Reverse action	
	PV high and low limits		Deviation high limit		
	Direct action	Reverse action	Direct action	Reverse action	
	Deviation low limit		Deviation high and low limits		
	Direct action	Reverse action	Direct action	Reverse action	
	SP high limit		SP low limit		
	Direct action	Reverse action	Direct action	Reverse action	
	SP high and low limits		MV high limit		
	Direct action	Reverse action	Direct action	Reverse action	
	MV low limit		MV high and low limits		
	Direct action	Reverse action	Direct action	Reverse action	
Heater burnout/overcurrent*1		Heater short circuit*1			
Direct action	Reverse action	Direct action	Reverse action		
Loop diagnosis 1					
<p>Turns on if the PV does not change according to the increase or decrease of the MV. Use this setting to detect a failure of the actuator, etc.</p> <ul style="list-style-type: none"> ● Setting items <ul style="list-style-type: none"> • Main setting: MV • Sub-setting: PV • ON delay time: diagnosis time ● Operation specifications <p>Turns ON if the PV set for the sub-setting is not reached within the diagnosis time (ON delay time) even though the MV greater than the main setting is retained.</p> ● Caution <p>To set the ON delay time, the user level (C079) must be set to Advanced. The ON delay time is set to 0.0 s when the product is shipped.</p> 					
Direct action		Reverse action			
For heating control		For cooling control			
If conditions 1 & 2 are met, ON delay starts		If conditions 1 & 2 are met, ON delay starts			

*1 If the event type is burnout/overcurrent or short circuit of the heater, there is no event detection from the time the power is turned on until the CT input current is measured for the first time. During this period, the internal event output is OFF regardless of the direct/reverse setting for the event. To prevent a reverse-acting event's output from turning OFF at power-on, set as follows.

Example of settings

Select the direct action for the event of burnout/overcurrent or short circuit of the heater, and set the output operation polarity of the terminal (event terminal or control output terminal) that outputs the event to "reverse" in the DO assignment bank.

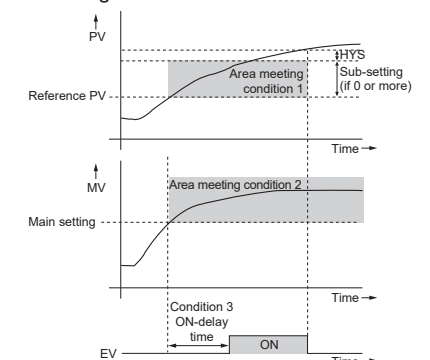
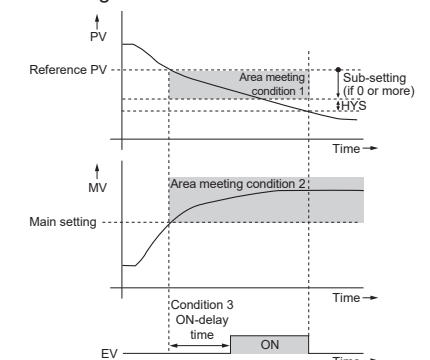
<p>Event</p>	<p>Event types</p> <ul style="list-style-type: none"> ●: ON/OFF changes at the value ○: ON/OFF changes when the value is exceeded by 1 U. 	<p>Loop diagnosis 2</p>	
	<p>Turns on if the PV does not change according to the increase or decrease of the MV. Use this setting to detect a failure of the actuator, etc.</p> <ul style="list-style-type: none"> ● Setting items <ul style="list-style-type: none"> ● Main setting: MV ● Sub-setting: the amount of the change in the PV from the time when the MV exceeds the value set for the main setting ● ON delay time: diagnosis time ● Operation specifications <p>Turns ON if the PV does not reach the value obtained by adding (subtracting) the sub-setting value to the PV when the MV exceeds the main setting (condition 1) within the diagnosis time (ON delay time) (condition 3) even though an MV greater than the main setting is retained (condition 2).</p> <ul style="list-style-type: none"> ● Caution <p>To set the ON delay time, the user level (C079) must be set to Advanced. The ON delay time is set to 0.0 s when the product is shipped.</p>		
	<p>Direct action</p>	<p>Reverse action</p>	
<p>For heating control</p>  <p>If conditions 1 & 2 are met, ON delay starts</p>		<p>For cooling control</p>  <p>If conditions 1 & 2 are met, ON delay starts</p>	

<p>Event</p>	<p>Event types</p> <ul style="list-style-type: none"> ●: ON/OFF changes at the value ○: ON/OFF changes when the value is exceeded by 1 U. 	<p style="text-align: center;">Loop diagnosis 3</p> <p>Turns on if the PV does not change according to the increase or decrease of the MV. Use this setting to detect a failure of the actuator, etc.</p> <ul style="list-style-type: none"> ● Setting items <ul style="list-style-type: none"> ● Main setting: the amount of the change in the PV from the time when the MV reaches the high limit (100 %) or the low limit (0 %) ● Sub-setting: the range of the absolute value of deviation (PV – SP) that will turn off the event ● ON delay time: diagnosis time ● OFF delay time: time from power-on to event OFF ● Operation specifications <ul style="list-style-type: none"> ● In direct operation (heating control), the event turns ON if: (1) the amount of PV increase after the diagnosis time (the ON-delay time) elapses after the MV reaches the high limit is smaller than the main setting or (2) the amount of PV decrease after the diagnosis time (the ON-delay time) elapses after the MV reaches the low limit is smaller than the main setting. ● In reverse operation (cooling control), the event turns ON if: (1) the amount of PV decrease after the diagnosis time (the ON-delay time) elapses after the MV reaches the high limit is smaller than the main setting or (2) the amount of PV increase after the diagnosis time (the ON-delay time) elapses after the MV reaches the low limit is smaller than the main setting. ● If the absolute value of deviation (PV – SP) is smaller than the sub-setting, the event turns OFF regardless of the other conditions. ● If the time from the start of operation after power-on is less than the OFF delay time, the event turns OFF regardless of the other conditions. However, after the absolute value of deviation exceeds the sub-setting, the event turns OFF if the absolute value of deviation becomes smaller than the value obtained by subtracting the hysteresis from the sub-setting. ● Caution <p>To set the ON and OFF delay times, the user level (C079) must be set to Advanced. The ON- and OFF-delay times are set to 0.0 s when the product is shipped.</p>
	<p style="text-align: center;">Direct action</p> <p style="text-align: center;">For heating control</p> <p style="text-align: center;">If conditions 1 & 2 are met, ON delay starts</p>	<p style="text-align: center;">Reverse action</p> <p style="text-align: center;">For cooling control</p> <p style="text-align: center;">If conditions 1 & 2 are met, ON delay starts</p>
	Alarm (status)	
	Direct action	Reverse action
	ON when an alarm (alarm code AL01 to AL99) occurs, OFF otherwise	OFF when an alarm (alarm code AL01 to AL99) occurs, ON otherwise
	READY (status)	
	Direct action	Reverse action
	ON in READY mode OFF in RUN mode	OFF in READY mode ON in RUN mode
	MANUAL (status)	
	Direct action	Reverse action
	ON in MANUAL mode OFF in AUTO mode	OFF in MANUAL mode ON in AUTO mode
	During AT (Auto-tuning)	
	Direct action	Reverse action
	ON when AT is running OFF when AT is stopped	OFF when AT is running ON when AT is stopped
	SP ramp in progress	
Direct action	Reverse action	
ON during SP ramp OFF when there is no SP ramp or it is completed	OFF during SP ramp ON when SP ramp is not used or is completed	

Event	<p>Event types</p> <ul style="list-style-type: none"> ●: ON/OFF changes at the value ○: ON/OFF changes when the value is exceeded by 1 U. 	Control direct action (status)	
		Direct action	Reverse action
		ON during direct action (cooling) OFF during reverse action (heating)	OFF during direct action (cooling) ON during reverse action (heating)
		While estimating valve opening (status)	
		Direct action	Reverse action
		ON during control with estimated position OFF when not estimating	OFF during control with estimated position ON when not estimating
		Timer (status)	
		<p>The direct and reverse action settings are disabled for timer events. To use timer events, set the operation type to Timer stop/start in the DI Assignment Bank. Multiple timer events can be controlled by a separate internal contact (DI) by setting event channel specification in the DI Assignment Bank.</p> <ul style="list-style-type: none"> ● Setting items <ul style="list-style-type: none"> ● ON delay time: Time until the event changes from OFF to ON after the DI changes from OFF to ON ● OFF delay time: Time until the event changes from ON to OFF after the DI is changed from ON to OFF ● Operation specifications <ul style="list-style-type: none"> ● Turns ON when DI ON continues for the ON delay time or longer. ● Turns OFF when DI OFF continues for the OFF delay time or longer. ● In other cases, the current status is retained. 	
		<ul style="list-style-type: none"> ● Caution <p>To set the ON and OFF delay times, the user level (C079) must be set to Advanced. The ON and OFF delay times are set to 0.0 s when the product is shipped. Event channel specification in the DI Assignment Bank is set to 0 when the product is shipped. With this setting, a timer can be started or stopped for all internal events by a single internal contact (DI). If the setting is changed to 1 or more, a timer can be started or stopped for one specified internal event by one internal contact (DI). To change the setting, the user level (C079) must be set to Advanced.</p> <ul style="list-style-type: none"> ● Setting of direct/reverse operation, standby, and READY mode operation These operations can be set at the time when the event (E1.C1 to E5.C2) is set up. 	
		RSP (status)	
		Direct action	Reverse action
RSP (status) ON in RSP mode OFF in LSP mode	OFF in RSP mode ON in LSP mode		

Event outputs (EV1–3) (option)	Number of outputs	3 (for models with EV outputs with common contacts) 2 (for models with EV outputs with independent contacts)
	Contact configuration	1a (SPST)
	Contact rating	250 V AC / 30 V DC, 2 A (resistive load)
	Service life	100,000 cycles or more
	Minimum switching specifications (reference value)	5 V, 10 mA
	Minimum switching specifications (close time)	50 ms
Auxiliary output (option)	Output accuracy	±0.1 % FS
	Output update cycle	Same as sampling cycle
	Current output	
	Output type	0 to 20 mA DC, 4 to 20 mA DC
	Allowable load resistance	600 Ω max.
RS-485 communication (option)	Transmission line	3-wire system
	Transmission speed	4800, 9600, 19200, 38400, 57600 bps
	Data length	8 or 7 bits
	Parity bit	Even parity, odd parity, no parity
	Stop bits	1 or 2
	Communication protocol	Host communication: Modbus™/RTU or Modbus™/ASCII
	Terminating resistor	External resistor (120 Ω, ½ W or more) recommended
	Network	Multidrop (up to 31 slave stations for 1 host station)
	Communications/synchronization type	Half-duplex, start/stop synchronization
	Maximum cable length	500 m
Standard conditions	Ambient temperature	25 ± 3 °C (provided there is a space of 2 cm below the product)
	Ambient humidity	60 ± 5 % RH (without condensation or freezing)
	Power supply voltage	105 V AC ± 10 %
	Power supply frequency	50/60 Hz ± 1 %
	Vibration	0 m/s ²
	Shock	0 m/s ²
	Mounting angle	(Reference plane) ±3°
Operating conditions	Ambient temperature	–10 to +55 °C (for independent mounting)
	Ambient humidity	10 to 85 % RH (without condensation or freezing)
	Power supply voltage	85 to 264 V AC, 50/60 Hz ± 2 % (rated power: 100 to 240 V AC, 50/60 Hz)
	Vibration	0 to 5 m/s ² (10 to 60 Hz for 2 h each in the x, y, and z directions)
	Shock	0 to 100 m/s ²
	Mounting angle	(Reference plane) ±10°
Transport and storage conditions	Ambient temperature	–20 to 70 °C
	Ambient humidity	10 to 85 % RH (without condensation or freezing, protected from humidity and dust)
	Power supply voltage	105 V AC ± 10 %
	Vibration	0 to 10 m/s ² (10 to 60 Hz for 2 h each in the x, y, and z directions)
	Shock	0 to 300 m/s ² (vertically 3 times)
	Package drop test	Drop height 60 cm (free fall on 1 corner, 3 edges, 6 sides)
General specifications	Nonvolatile memory	EEPROM
	Time accuracy (reference)	±0.18 s typ. (per hour)
	Power consumption	12 VA max. (9 VA at 100 V AC, 12 VA at 264 V AC)
	Allowable transient power loss	20 ms max.
	Elevation	2000 m max.

General specifications	Weight	R3A: Approx. 220 g R3B: Approx. 280 g (including the supplied mounting bracket, model No. 84525941-001)
	Installation location	Indoors
	Installation	Panel mounting (using the supplied mounting bracket, model No. 84525941-001)
	Terminal screw tightening torque	0.6 ± 0.1 N·m
	Overvoltage category	Category II (IEC60364-4-443, IEC60664-1)
	Insulation resistance	20 MΩ min. (Power terminals, and between power terminals and isolated I/O terminals) (with a 500 V DC insulation resistance tester)
	Dielectric strength	1,500 V AC, 1 min (Power terminals, and between power terminals and isolated I/O terminals)
	Power-on inrush current	18 A max. / 3 ms max.
	Case material, color	Modified PPE, black
	Front panel material	Polycarbonate resin
Control	Number of loops	1
	Control method	PID and ON/OFF control
	Control operation	Heating control (reverse action), cooling control (direct action)
	Control output	Continuous proportional (when current is selected for control output), time proportional (when relay is selected for control output)
	Control algorithm	PID (conventional PID), Ra-PID (high-performance PID)
	PID control	
	Proportional band (P)	0.1 to 1999.9 %
	Integral time (I)	0 to 19999 U (0 = no integral operation) (set the number of decimal places (0 to 3) for integral time and derivative time)
	Derivative time (D)	0 to 19999 U (0 = no derivative operation) (set the number of decimal places (0 to 3) for integral time and derivative time)
	Output low limit, output high limit	-10.0 to +110.0 %
	Manual reset	-10.0 to +110.0 %
	Number of PID groups	8
	PID group selection	A PID group can be set for each SP group or can be selected by a function assigned to DI or by communication.
	Auto tuning method	PID automatic setting using the limit cycle method
	Auto-tuning type	0: Normal (regular control characteristics) 1: Immediate response (to disturbance) 2: Stable (minimal PV fluctuation)
	Auto tuning adjustment factor	0.00 to 199.99 (specifiable for proportional band, integral time, and derivative time)
	MV switching point type for auto tuning	0: Default (2/3 of the deviation of the initial PV from the initial SP), 1: SP, 2: PV
	MV switching point PV for auto tuning	-19999 to +19999 U
	Control cycle	Same as sampling cycle
	ON/OFF control	
Differential	0 to 19999 U	
Operating point offset	-19999 to +19999 U	

*1 During EMC testing, the indication or output may fluctuate by the equivalent of ±10 % FS.

Control	SP	
	Number of LSP groups	8 max.
	SP ramp type	0: Standard 1: Multi-ramp
	SP ramp unit	0: 1 s, 1: 1 min, 2: 1 h
	SP up/down ramp slope	0.1 to 19999 U (0.0 U: no ramp)
	Pattern operation	
	Number of segments	Up to 8 segments
	Segment setting method	Set by an SP and a time
	Time unit	0: 1 s, 1: 1 min, 2: 1 h
	Function	PV start, Cycle, Pattern link
Output operation at PV alarm	0: Continue control calculations, 1: Output the value set for Output at PV alarm	
Output at PV alarm	-10.0 to +110.0 %	
Output at READY	-10.0 to +110.0 %	
Internal contact	Operation type	LSP group selection (0/+1), LSP group selection (0/+2), LSP group selection (0/+4), PID group selection (0/+1), PID group selection (0/+2), PID group selection (0/+4), RUN/READY selection, AUTO/MANUAL selection, AT stop/start, control operation direct/reverse selection, SP ramp enabling/disabling, PV hold, PV max. hold, PV min. hold, Timer stop/start, Release/continue all DO latches, Advance (disabled/enabled), SP step hold (disabled/enabled)
Current transformer (CT) operation (depending on model No.)	Operation	0: Continuous current measurement, 1: Heater burnout detection
	Measurement wait time	30 to 300 ms
	Number of turns	100 to 6000 turns
	Number of power wire passes	1 to 6 times

Table 3. Behavior if a PV Input Error Occurs

If a PV input error occurs, this device will operate as follows.

Control output: Whether to continue operation can be specified.

Other operations: Operation continues.

Input type	Error	PV input range type	Indication	Alarm code
Resistance temperature detector (RTD)	Resistor burnout	41 to 70	Upscale (110 % FS)	AL01
	Line A burnout			
	Line B burnout	41 to 70	Upscale (110 % FS)*1	AL01 AL03 (AL02)
	2- or 3-wire burnout			
	Short circuit, lines A and B	41 to 44	Downscale (-235 °C)	AL02
45 to 70		Downscale (-10 % FS)	AL02	
DC voltage (mV)	Burnout	81 to 83	Upscale (110 % FS)	AL01
DC voltage (V)	Burnout	84	Unknown (around 0 % FS)	None
		86	Downscale (-10 % FS)	AL02
		87	Unknown (around 0 % FS)	None
		88	Unknown (around 0 % FS)	None
		91	Downscale (-10 % FS)	AL02
		92	Unknown (around 50 % FS)	None
DC current	Burnout	89	Unknown (around 0 % FS)	None
		90	Downscale (-10 % FS)	AL02

Table 4. Operation upon RSP input wire burnout

If an RSP input error occurs, all operations will continue.

If the RSP input is abnormal, this device will display the alarm codes and values shown in the tables below.

Input type	Error	PV input range type	Indication	Alarm code
DC voltage (V)	Burnout	84	Downscale (0 % FS)	None
		86	Downscale (-10 % FS)	AL06
		87	Downscale (0 % FS)	None
		88	Downscale (0 % FS)	None
		91	Downscale (-10 % FS)	AL06
		92	Unknown (around 50 % FS)	None
DC current	Burnout	89	Unknown (around 0 % FS)	None
		90	Downscale (-10 % FS)	AL06

*1 It may be upscaled after the indicated value drops for a short period of time.

■ Dimensions

● Model R3A

(Unit: mm)

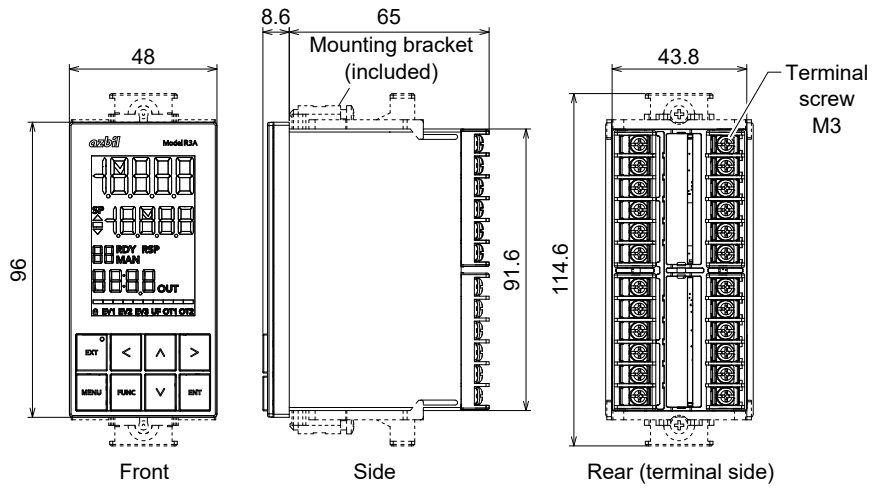

● Model R3B

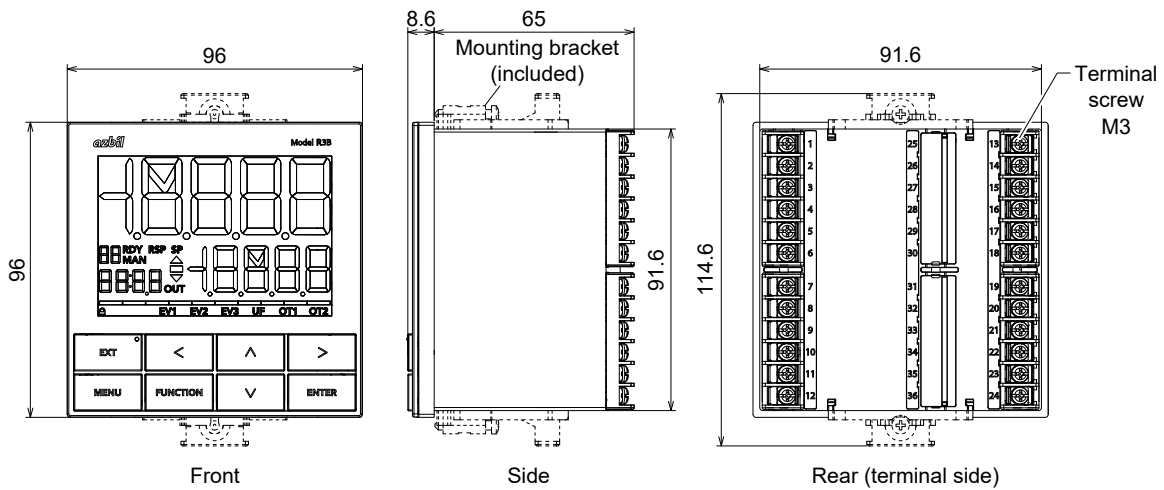

(Note)

1. Do not block the ventilation holes.
2. When using fans or coolers, make sure the air will not directly blow on this device.
3. Mount this device horizontally with the back not tilted more than 10° up or down.
4. Use a rigid panel whose thickness is no more than 8 mm.
5. Do not tighten screws too tightly because the case may be deformed.

● Panel cutout dimensions

- Model R3A

(Unit: mm)

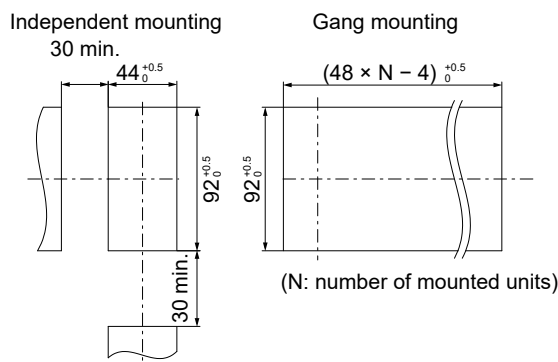

- Model R3B

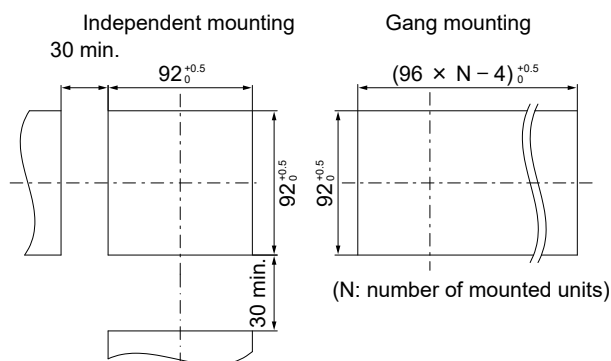

(Note)

1. The maximum allowable ambient temperature for gang-mounted products: 50 °C (two units), 45 °C (three or more units)
2. When waterproofing and dustproofing are required, mount the units individually. If units are gang mounted, waterproofing and dust-proofing performance cannot be maintained.
3. Leave a space of at least 30 mm above and below this device.
4. For gang mounting using a soft cover, make a $(51 \times N - 7)^{+0.5}_0$ mm hole for the R3A and a $(99 \times N - 7)^{+0.5}_0$ mm hole for the R3B.

■ Names of Parts

● Model C1A and its console

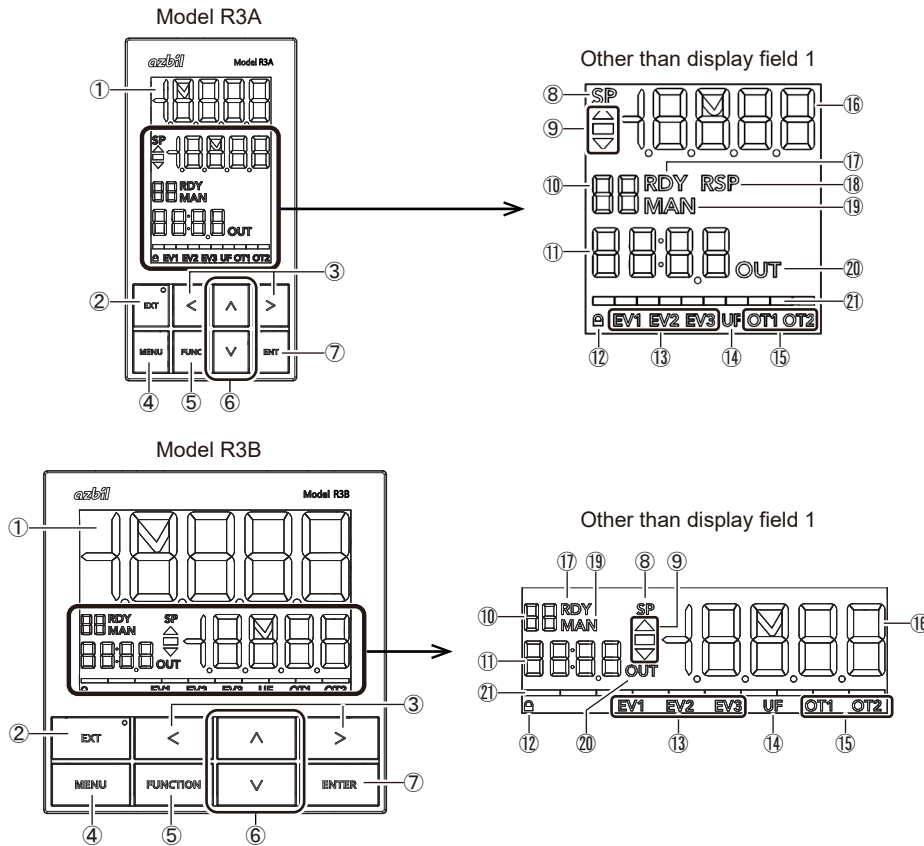

①	Display field 1	Shows PV (present temperature, etc.) and items that can be set. When an alarm occurs, the normal display and an alarm code are displayed alternately.
②	[EXT] key	—
③	[<] and [>] keys	Used for shifting between the digits of a number.
④	[MENU] key	Switches between the operation display, bank selection display, and settings display.
⑤	[FUNC] and [FUNCTION] keys	If it is held down for 2 seconds or longer when the operation display is shown, the preset operation (initial setting: AUTO/MANUAL selection) can be executed.
⑥	[^] and [v] keys	Used for incrementing/decrementing numeric values.
⑦	[ENT] and [ENTER] keys	Finalizes the entered value.
⑧	SP indicator	Lights up when the SP is displayed in display field 2.
⑨	Ramp indicator	Indicates the operating status of a pattern operation, SP ramp, and RSP ramp.
⑩	Display field 4	Shows the segment No. during a pattern operation or user operation screen No.
⑪	Display field 3	Shows the manipulated value (MV) or present values of monitored items.
⑫	Lock indicator	Lights up when any of the lock functions is enabled.
⑬	Event indicator	Lights up when the corresponding event output is ON.
⑭	User-defined function indicator	Lights up according to the setting of the user-defined function indicator.
⑮	Control output indicator	Lights up when the corresponding control output is ON.
⑯	Display field 2	Shows the SP (set temperature, etc.) or other settings.
⑰	RDY mode indicator	Lights up in READY (control stop) mode.
⑱	RSP mode indicator	Lights up in RSP mode.
⑲	MAN mode indicator	Lights up in MANUAL mode.
⑳	MV indicator	Lights up when the MV is displayed in display field 3.
㉑	Multi-status (MS) indicator	Various ON/OFF states or analog values such as an MV graph can be displayed by specifying the light-up condition and design.

● Terminals

- Model R3A

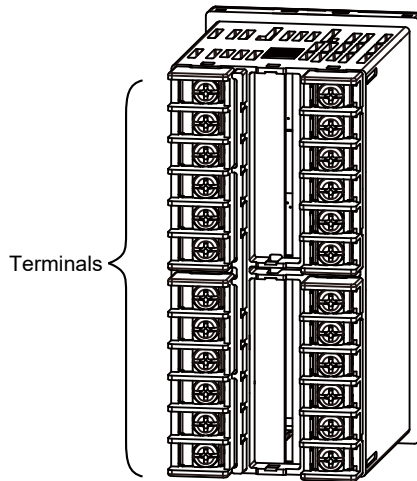

- Model R3B

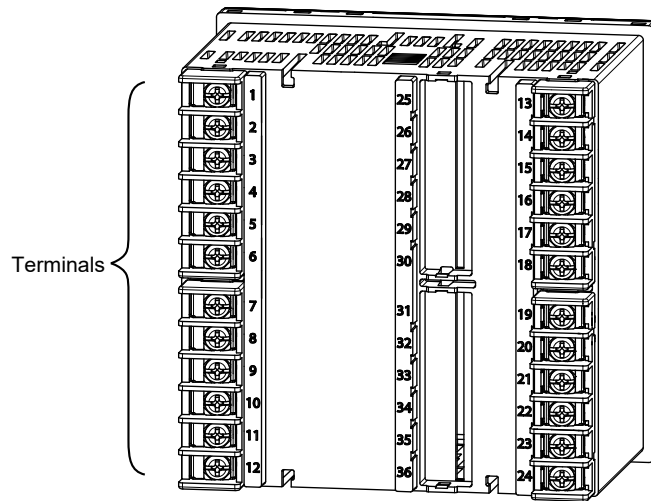

Terminal Connections

Run the lead wires to each terminal in the direction indicated below.

① to ⑫: to the left

⑬ to ⑳: to the right

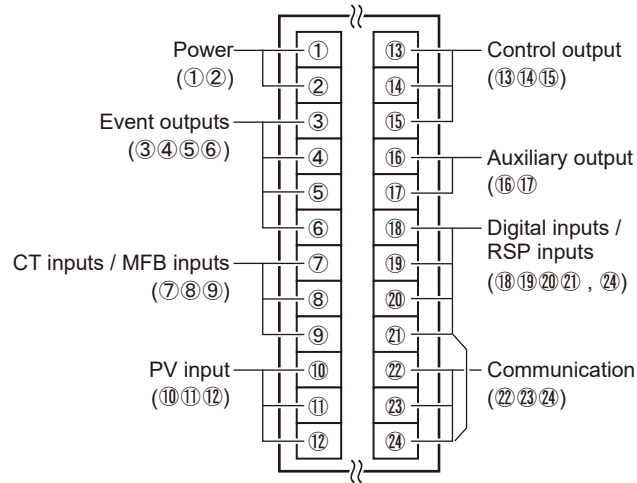

Sample input/output that can be connected to terminals

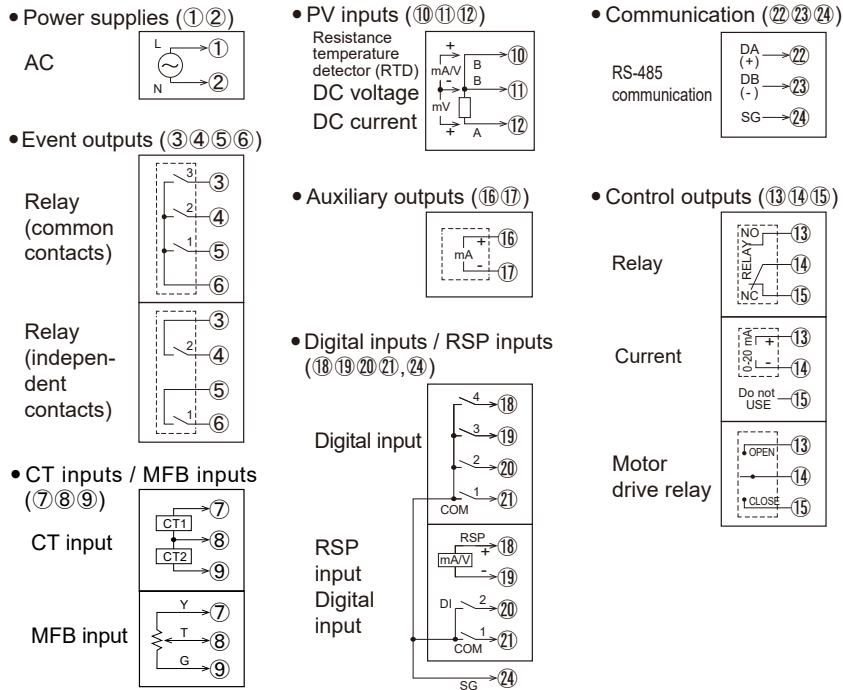

■ RS-485 Communication Connections

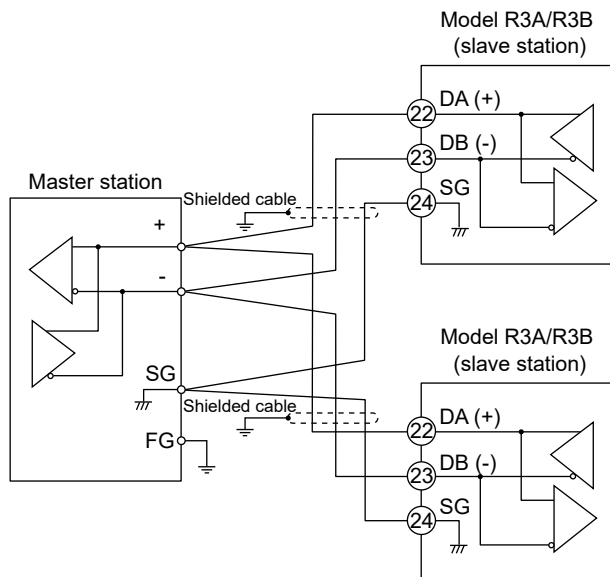

IMPORTANT • Terminating resistor
 Connect a terminating resistor (120 Ω, 1/2 W or more recommended) to both ends of the RS-485 transmission line.
 However, if terminal resistance is not specified for other devices connected to the same transmission line, do not connect the resistor. If they do specify a resistor, use the highest resistance value specified, at least 120 Ω.

(Note)

1. Do not connect DA (+) to DB (-). Doing so might damage this device.
2. Ground only one end of the shielded cable.
3. Be sure to connect the SG terminals to each other.
 Failure to do so might cause unreliable communication.

(Reference) For details on the connection and other connections, refer to AB-7729, Model R3A/R3B User's Manual for Installation.

● Recommended cable

Signal line: JCS 4364 cable for low-power instruments

● Recommended crimp terminals

Use crimp terminal lugs compatible with M3 screws.

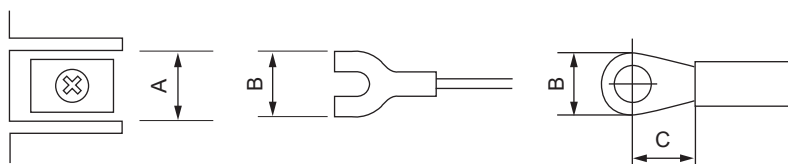

Mounting method	Compatible screw	Terminal dimensions (mm)			Compatible wire size	J.S.T. Mfg. Co., Ltd. Model No. (reference)
		A	B	C		
R3A/R3B (for panel mounting)	M3	6.1	5.8 max.	5.5 to 7.6	0.3 to 1.2 mm ² 22 to 16 AWG	V1.25-MS3 (round terminals)

(Note) Be careful not to allow crimp terminal lugs to touch adjacent terminals.

■ Precautions When Using Self-tuning

When using self-tuning, be sure to turn on the actuator at the same time as or before turning on the instrument.

■ Wiring Precautions

1. Isolation in the instrument

Items enclosed by solid lines are isolated from other signals. The presence or absence of input/output depends on the model.

AC power	Internal circuits	Event outputs 1–3 * On models with independent contacts, event outputs 1 and 2 have reinforced insulation.
		Control output (relay, motor drive relay)
RSP		Control output (current)
MFB		CT input
AUX (current)		
DI		PV
RS-485		

2. Noise suppression measures for the instrument power supply

(1) Noise reduction

Even if the amount of electrical noise is small, use a noise filter to minimize its effect.

Line filter model No.: 81442557-001 (equivalent to TDK RSHN-2010)

(2) If there is a large amount of electrical noise

If there is a large amount of electrical noise, use an isolation transformer and a line filter to minimize its effect.

3. Sources of electrical noise in the installation environment and measures

The following are typical sources of electrical noise in the installation environment:

relays and contacts, magnet coils, solenoid valves, power lines (especially 100 V AC or higher), motor commutators, phase angle control SCRs, radio communication devices, welding machines, high-voltage ignition devices, etc.

Measures against quick-rising noise

The CR filter is effective against quick-rising noise.

Recommended filter model: 81446365-001

4. Note on wiring work

(1) Do not bundle the primary and secondary coils of the power cable together or put them into the same conduit or duct after introducing noise-reduction measures.

(2) The input/output and communication wires should be at least 50 cm away from power lines for motors or power cables carrying 100 V AC or higher. Also, do not put these two types of wires in the same conduit or wiring duct.

5. Inspection after wiring

After wiring, be sure to inspect and check the wiring status. Note that incorrect wiring may cause instrument failure or an accident.

This blank page was added for page layout purposes.



Install this product where it is accessible only to people with sufficient knowledge concerning electrical equipment. This product complies with the following harmonised standards of the Electromagnetic Compatibility Directive (EMCD) and the Low Voltage Directive (LVD).

EMCD: EN 61326-1 Class A, Table 2 (for use in an industrial electromagnetic environment)
LVD: EN 61010-1 Overvoltage category II
Pollution degree 2

Modbus is a trademark and the property of Schneider Electric SE, its subsidiaries and affiliated companies.
Other company, product, and service names mentioned in this document are trademarks or registered trademarks of their respective owners.

Azbil Corporation
Building Systems Company

1-12-2 Kawana, Fujisawa, Kanagawa
251-8522 JAPAN

<https://www.azbil.com/>

AS-1019E
Rev. 1.0 Apr. 2026
(J: AS-1019 Rev. 1.0)

Specifications are subject to change without notice.