

Network Instrumentation Modules

Communications box Model NX-CB1

Communications adapter Model NX-CL1/CR1

Terminal adapter Model NX-TL1/TR1

Overview

Network Instrumentation Modules make optimal distributed configuration a reality. Distributed modules execute cooperative control using Ethernet connectivity. This instrumentation offers an excellent solution for productivity and energy conservation needs.

The following devices are Ethernet-compatible, a key feature of Network Instrumentation Module instrumentation.

- Communications box Model NX-CB1
- Communications adapter Model NX-CL1/CR1
- Terminal adapter Model NX-TL1/TR1

Features

- Communications box
 - Equipped with 4 Ethernet ports on the front and 1 on the right side (side connector).
 - Ethernet connections between modules via side connectors reduce wiring.
 - Reduced wiring and distributed layout by Ethernet daisy chain
 - Redundancy by Ethernet ring connection
 - LED information indicators
- Communications adapter
 - Equipped with an Ethernet port on the front.
 - No power supply is needed.
- Terminal adapter
 - Used for Ethernet chain ring connections (using side connector).
 - No power supply is needed.

Model NX-CB1



Model NX-CL1/CR1



Model NX-TL1/TR1



Basic function block of model NX-CB1

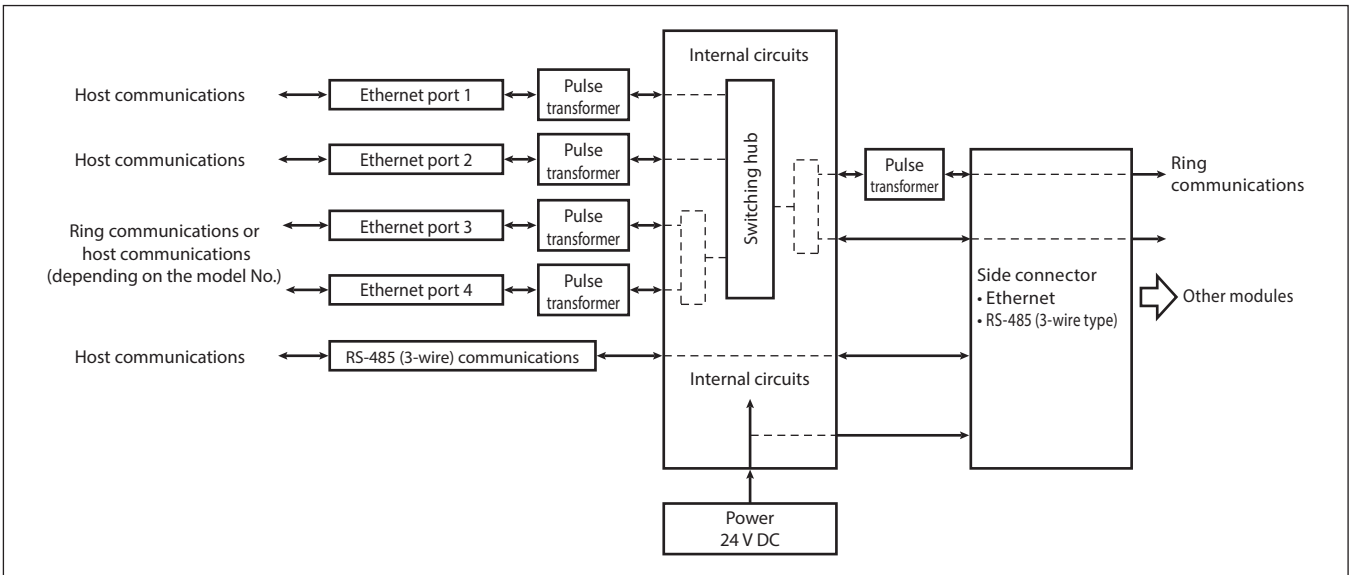

Basic function block of model NX-CL1/NX-CR1

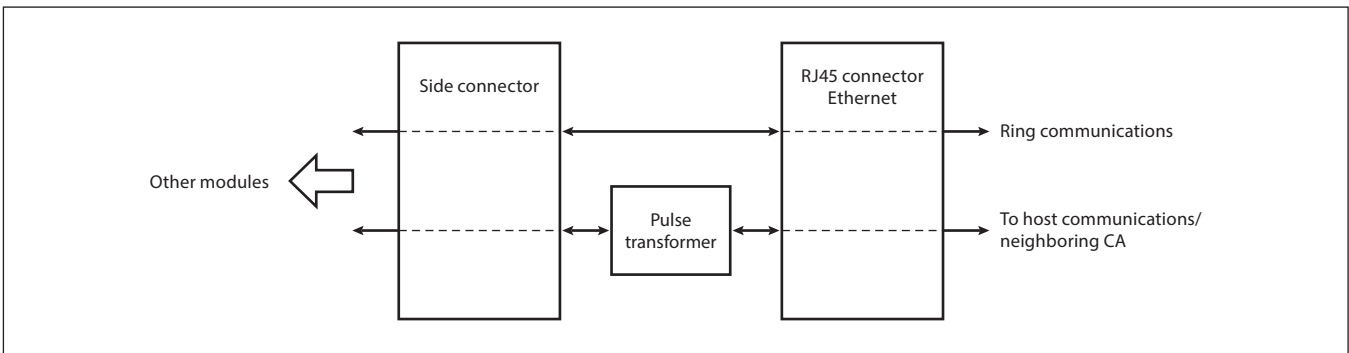

Basic function block of model NX-TL1/NX-TR1

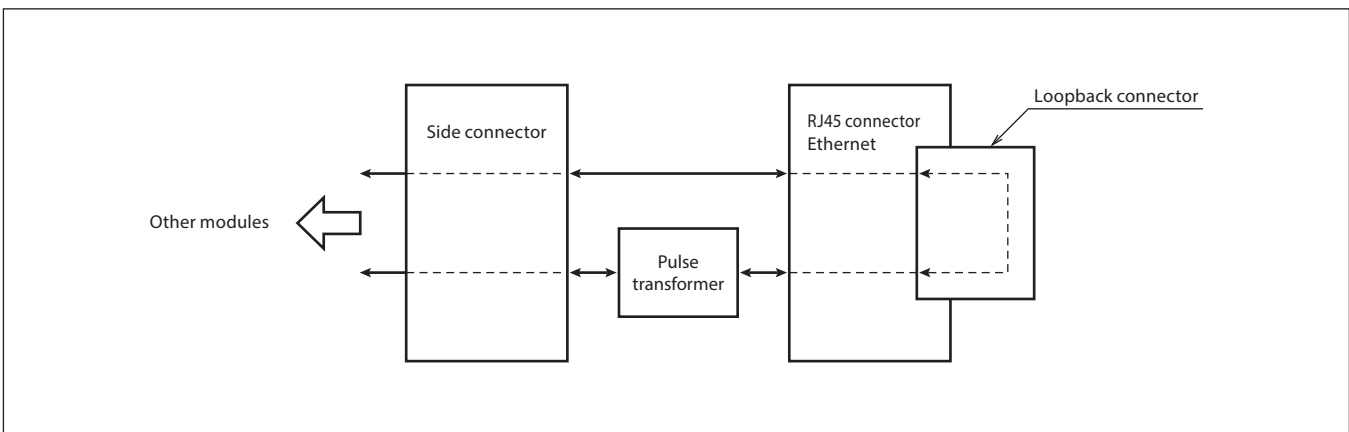

Item		Description	
Communication specifications	NX-CB1	Ports	4
		Communication path type	Ethernet port 1/2 IEEE 802.3/IEEE 802.3u 10BASE-T/100BASE-TX (with Auto Negotiation and Auto MDI/MDI-X functions)
			Ethernet port 3/4 IEEE 802.3u 100BASE-TX (with full duplex and Auto MDI/MDI-X functions. The auto negotiation function on a connected device should be enabled except when the device is connected between communication boxes.)
		Connector	RJ-45
		Cable	UTP cable (4P) Cat 5e min. (straight) (both ends, ANSI/TIA/EIA-568-B)
	NX-CL1/NX-CR1	Ports	1
		Communication path type	IEEE 802.3u 100BASE-TX (with full duplex and Auto MDI/MDI-X functions. The auto negotiation function on a connected device should be enabled between communication boxes.)
		Connector	RJ-45
		Cable	UTP cable (4P) Cat 5e min. (straight) (both ends, ANSI/TIA/EIA-568-B)
General descriptions	Standard conditions	Ambient temperature	23 ± 2 °C
		Ambient humidity	60 ± 5 % RH (without condensation)
		Rated voltage	NX-CB1: 24 V DC
		Vibration resistance	0 m/s ²
		Shock	0 m/s ²
		Mounting angle	Reference plane ± 3°
	Operating conditions	Ambient temperature	0 to 50 °C (below the installed NX)
		Ambient humidity	10 to 90 % RH (without condensation)
		Allowable operating voltage	NX-CB1: 21.6 to 26.4 V DC
		Vibration	0 to 3.2 m/s ² (10 to 150 Hz for 2 h each in x, y, and z directions)
		Shock	0 to 9.8 m/s ²
		Mounting angle	Reference plane ± 3°
		Dust	0.3 mg/m ³ max.
		Corrosive gas	None
		Altitude	2000 m max.
		Pollution degree	2 (equivalent to normal office environments)
	Transport and storage conditions	Ambient temperature	-20 to +70 °C
		Ambient humidity	5 to 95 % RH (without condensation)
		Vibration	0 to 9.8 m/s ² (10 to 150 Hz for 2 h each in x, y, and z directions)
		Shock	0 to 300 m/s ² (vertically 3 times while on DIN rail)
		Package drop test	Drop height 60 cm (free fall on 1 corner, 3 edges, 6 sides)
	Memory storage system	NX-CB1: Non-volatile (EEPROM)	
	Power consumption	NX-CB1: 4 W max. (under operating conditions)	
	Inrush current	NX-CB1: 10 A max. (under operating conditions)	
	Power ON operation delay	NX-CB1: Reset time: 3 s min. (required until normal operation begins under standard conditions)	
	Insulation resistance	NX-CB1: 20 MΩ min. (between power terminals 1 and 2 and I/O terminals isolated from the power terminals, with a 500 V DC megger)	
	Dielectric strength	NX-CB1: 500 V AC for 1 min (between power terminals 1 and 2 and I/O terminals isolated from the power terminals)	
	Case material, color	Modified PPO resin, black	
	Standards compliance	NX-CB1: EN61326-1 (For use in industrial locations), UL61010-1, CAN/CSA C22.2 No.61010-1	
	Mounting method	DIN rail	
	Terminal screw tightening torque	0.6 ± 0.1 N·m	
	Mass	NX-CB1: 300 g max. NX-CL1/CR1: 35 g max. NX-TL1/TR1: 37 g max.	
	Accessories	NX-CB1: User's manual (CP-UM-5558JE)	

Model Selection

Communications box

Basic model No.	Type	Ring connection 1	Ring connection 2	Output type	Option	Addition	Description
NX-							Network Instrumentation Module
	CB1						4-port switching hub
		N					Chain non-ring connection (using side connector)
		R					Chain ring connection (using side connector)
			N				Non-ring connection between chains (using front port)
			R				Ring connection between chains (using front port)
				04			4-port
					0		RJ45 connector
						0	None
						D	Inspection certificate
						T	Tropicalization treatment
						K	Anti-sulfide treatment
						B	Tropicalization treatment + inspection certificate
						L	Anti-sulfide treatment + inspection certificate

Communications adapter/Terminal adapter

Basic model No.	Type	Option 1	Option 2	Option 3	Option 4	Addition	Description
NX-							Network Instrumentation Module
	CL1						Communications adapter for left side *
	CR1						Communications adapter for right side *
	TL1						Terminal adapter for left side Chain ring connection (using side connector) *
	TR1						Terminal adapter for right side Chain ring connection (using side connector) *
		0					None
			0				None
				00			None
					0		None
						0	None
						D	Inspection certificate
						T	Tropicalization treatment
						K	Anti-sulfide treatment
						B	Tropicalization treatment + inspection certificate
						L	Anti-sulfide treatment + inspection certificate

* Left and right are defined as seen when viewing the front of the unit after mounting.

External Dimensions

(Unit: mm)

• Communications box NX-CB1

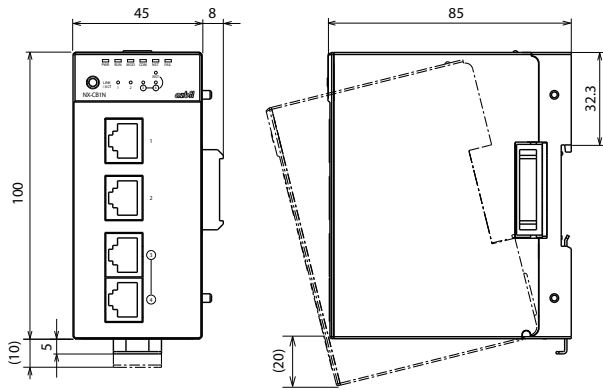

• Communications adapter NX-CL1/NX-CR1

for left side NX-CL1

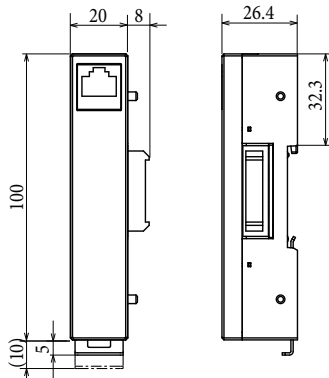

for right side NX-CR1

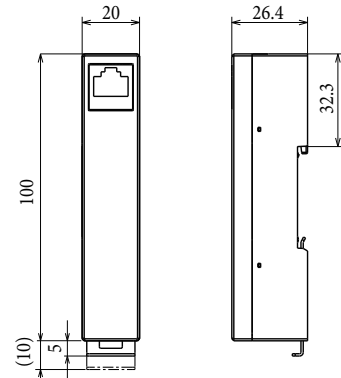

• Terminal adapter NX-TL1/NX-TR1

for left side NX-TL1

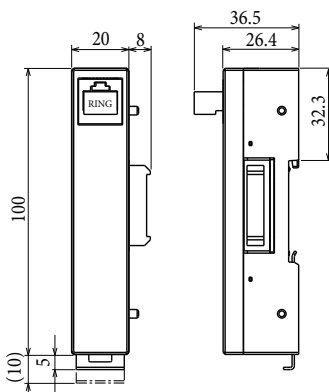

for right side NX-TR1

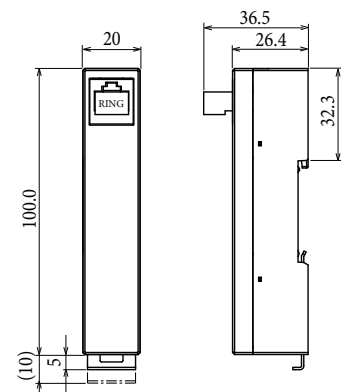

Part Names and Functions

Body

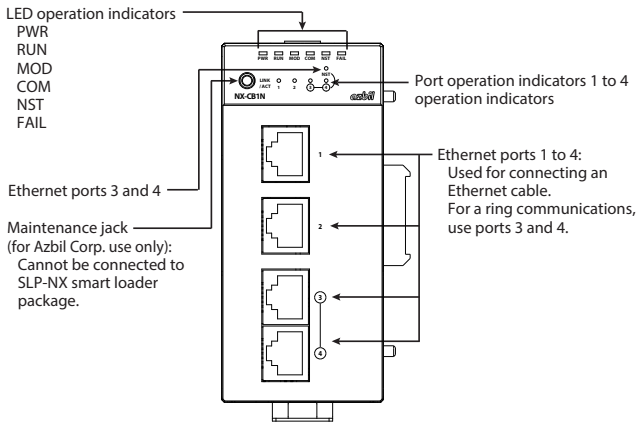

Base

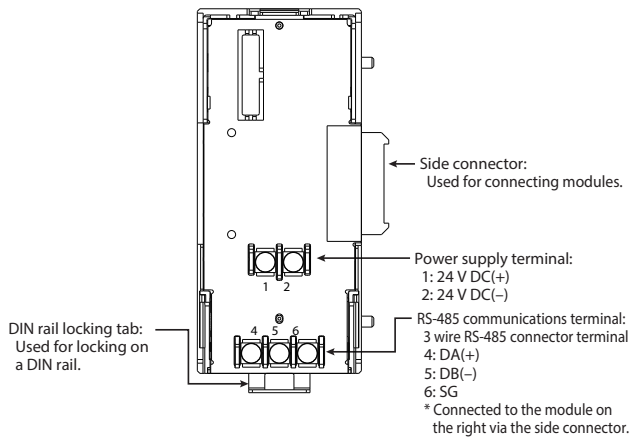

Mounting

Location

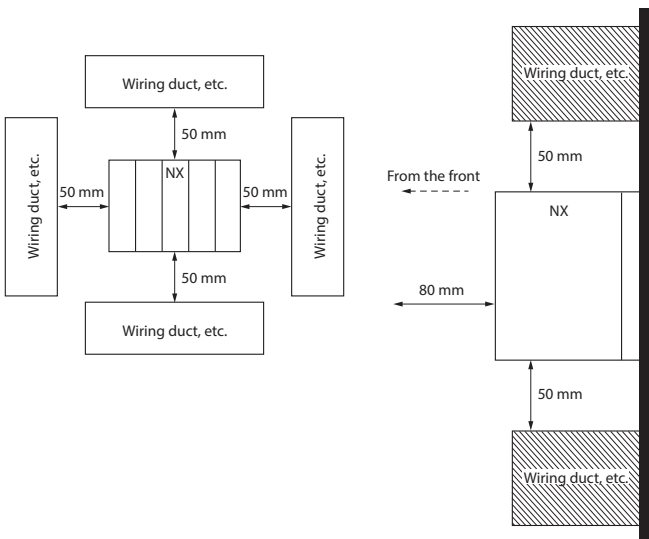

Install the controller in a location that meets the following criteria:

- Install the controller in a location that meets the following criteria:
- No high/low temperature/humidity.
- Free from sulfide gas or corrosive gas.
- Not dusty or sooty.
- Protected from direct sunlight, wind, and rain.
- Little mechanical vibration or shock.
- Not close to high voltage line, welding machine or other electrical noise generating source.

- At least 15 meters away from the high voltage ignition device for a boiler.
- No strong magnetic fields.
- No flammable liquid or gas.
- Indoors
- I/O common mode voltages: voltage to ground is 30 Vrms max., 42.4 V peak max., and 60 V DC max. (not in a wet location).

Linking modules

The NX-CB1 can be linked to other modules using the connectors on the right of the base. When linked, modules share the power supply connection, eliminating the need for wiring.

Mounting procedure

The NX-CB1 is used while mounted on a DIN rail. After mounting the DIN rail and pulling the locking tab completely off, hook the base onto the DIN rail. Then, push the DIN rail locking tab upwards firmly until it clicks into place.

! Handling Precautions

- Install the module so that it is vertical, with the DIN rail locking tab at the bottom.
- Link the NX-CB1 to the other modules before mounting it on a DIN rail.

Attaching the main unit to the base

! Handling Precautions

- The included base and main unit must be used as a pair.
- Be sure to fit the hook on the main unit into the base first. If this is not done, the hook might be broken during mounting.

- (1) Fit the hook on the main unit into the base.
- (2) Push the main unit onto the base until it clicks into place.

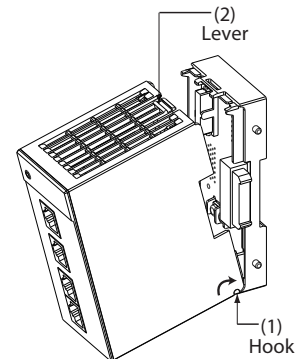

To remove the main unit from the base, pull it towards you while pressing down on the lever.

WIRING

■ Wiring Precautions

- Do not run wires outside. The equipment could be damaged in the event of lightning.
- When connecting wires to the power terminals, use crimp terminals with insulating sleeves.
- Check the model number of the controller and the terminal numbers on the wiring diagram on the side of the module to prevent any wiring errors.
- For power supply terminal, RS-485 communication terminal connections, use crimp terminals that are the correct size for M3 screws.
- Be careful not to allow any crimp-type terminal lugs to touch adjacent terminals.
- The signal wires and power wires of the module should be at least 60 cm away from other power wires or power sources. Also, do not pass these wires through the same conduit or wiring duct.
- Before connecting the NX-CB1 to other devices in parallel, check their connection conditions carefully.
- To ensure stable operation, the NX-CB1 is designed not to operate for three seconds after the power is turned ON.
- After wiring, check that there are no mistakes before turning the power ON.

■ Wiring Precautions

For ring network, connect communication cables to Ethernet ports 3 and 4.

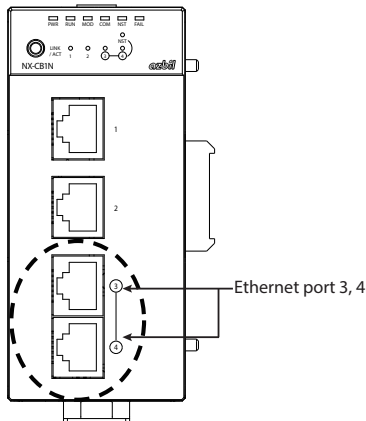

■ Connecting the power supply

Connect the power terminals as shown below.

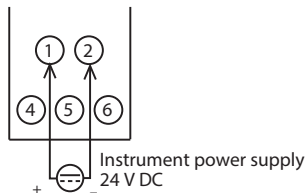

! Handling Precautions

- Linked modules supply power to each other.
- Supply power to one of the linked modules.
- Use a power supply that can supply the total power requirement of the linked modules.
- For compliance with UL standards, use a UL-approved Class 2 power supply.

■ Connecting the RS-485 communications

Connect the RS-485 wiring for CPL or Modbus™ as shown below

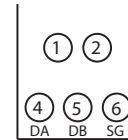

! Handling Precautions

- 0.5 W or greater terminating resistor of $150 \Omega \pm 5\%$ at each end of the communications lines. However, if any device that does not allow a terminating resistor is connected to the same communications line, follow the instructions on that device.
- Be sure to connect the SG terminals to each other. Failure to do so might cause unstable communications.
- For communications wiring, use twisted pair cables.
- Since the module has no RS-485 communication function, connect another module to the right-hand connector on the module base and connect a communication cable to that module.

■ I/O isolation

Items surrounded by solid lines are isolated from other signals.

NX-CB1

Power supply (including side connector) *1	
Logic circuits	Ethernet port 1
Maintenance jack	Ethernet port 2
RS-485 communications (SG only) *1 *2	Ethernet port 3
Indicators (led)	Ethernet port 4
Ethernet communications through side connector *1	
Ring communications through side connector *1	

*1. Power, side-connector ring communications, and RS-485/side-connector Ethernet communications are isolated from each other.

*2. DA and DB signals for RS-485 communications are connected not to the module's internal circuitry, but instead directly to the side connector.

NX-CL1/NX-CR1

Ethernet communications through side connector *1	Ethernet port 1, 2, 3 and 6-pin
Ethernet port 4, 5 and 8-pin	
Ring communications through side connector *1	

Ethernet connections

For details, see *Network Instrumentation Module User's Manual: Network Design Version*, No. CP-SP-1313E.

A good understanding of connection methods, model selection, etc. is required before use.

• Abbreviations

Notation	Explanation
CA	Communications adapter
TA	Terminal adapter
CB	Communications box

• Node notations

Notation	Explanation
R	Ring communication type
N	Non-ring communication type

• CB notations

Notation	Explanation
RR	Chain connection : Ring communication type Connection between chains : Ring communication type
RN	Chain connection : Ring communication type Connection between chains : Non-ring communication type
NR	Chain connection : Non-ring communication type Connection between chains : Ring communication type
NN	Chain connection : Non-ring communication type Connection between chains : Non-ring communication type

■ Basic network configuration

The network is configured by linking modules.

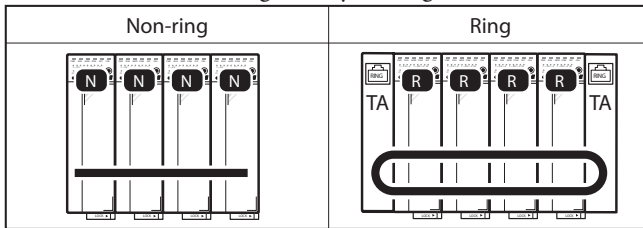

A distributed configuration can be achieved using an Ethernet cable.

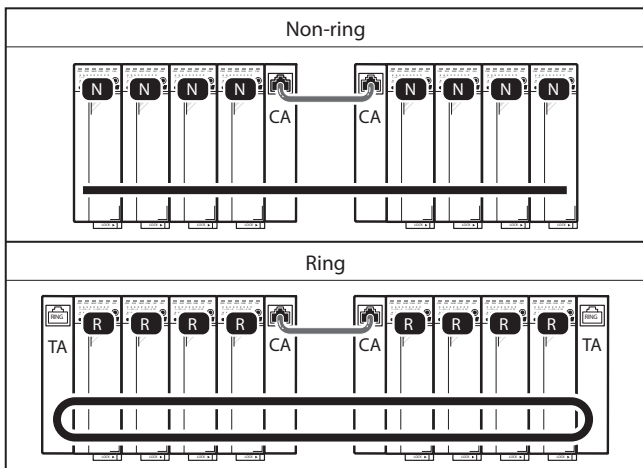

Even if modules are connected using Ethernet cables, they are recognized as one chain in the SLP-NX

This type of distributed configuration is suitable when modules are located relatively close together, for example, in the same platform or a neighboring platform (with a connecting cable that is less than 50 m in length).

■ Attaching the main unit to the base

The following four types of network configurations are possible, depending on the model number of the communication box.

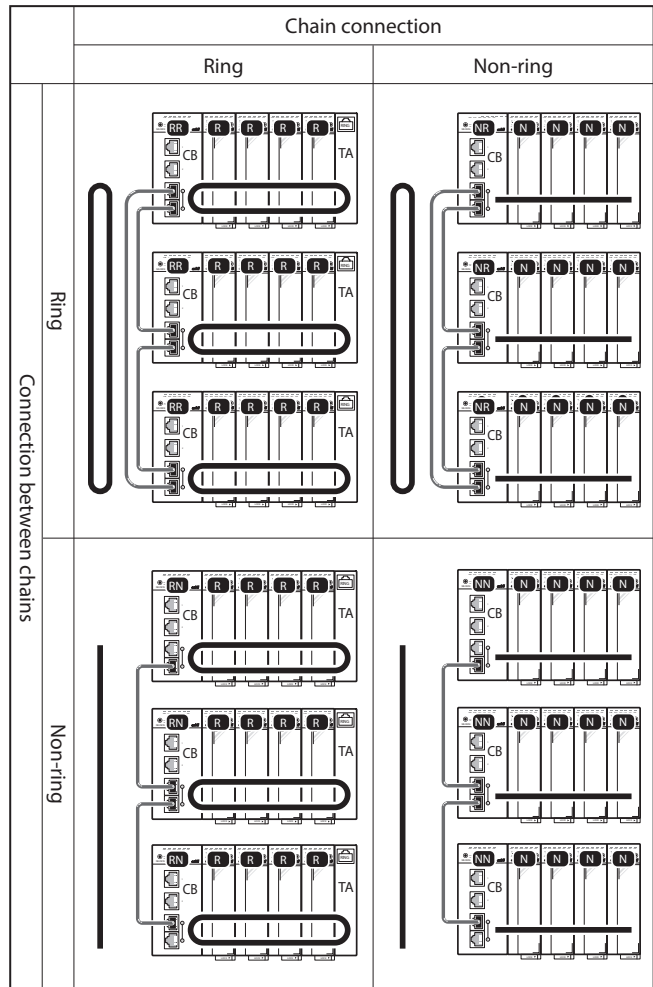

Communication adapters can be used to set up a distributed configuration for chain connections (the horizontal connections in this diagram).

Connections between chains (the vertical connections in this diagram) are performed when connecting modules located in different locations.

■ **Configuration Methods**

- **Chain connection: non-ring communications**
Modules are configured in a daisy chain topology.

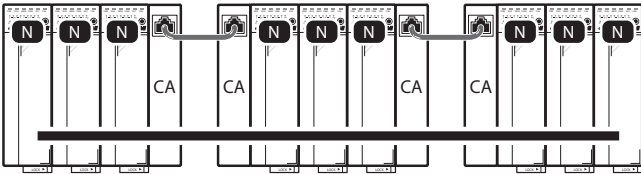

- **Chain connection: ring communications**

You can build a redundant communication path by connecting daisy chain topology to ring topology.

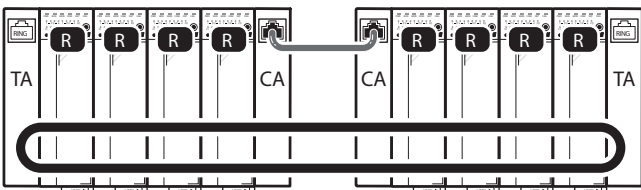
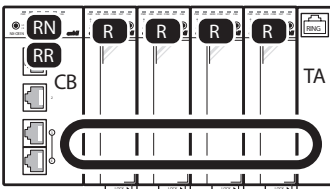
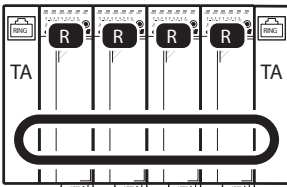

- **Chain connection: non-ring communications**

Redundant communications can be built using a communication box and daisy chain topology in a ring-type network.

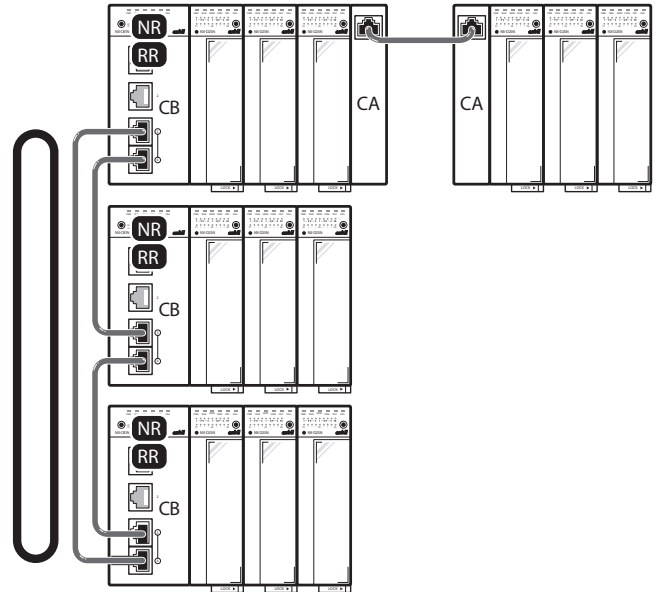

■ **Connection between chains: non-ring communications**

Chains can be connected using communication boxes and daisy chain topology.

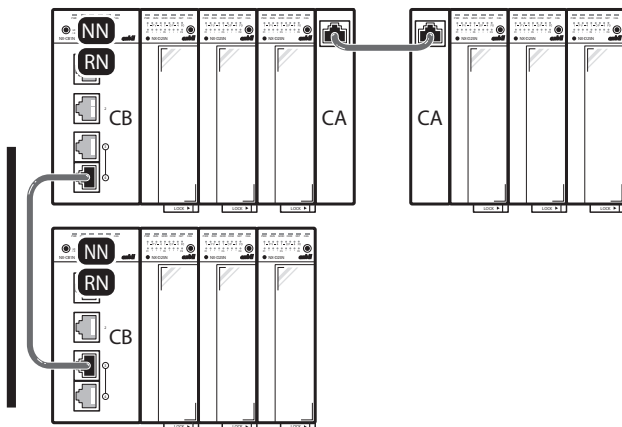

- Ethernet is a trademark of FUJIFILM Business Innovation Corp.
- Modbus is a trademark and the property of Schneider Electric SE, its subsidiaries and affiliated companies.

Please read "Terms and Conditions" from the following URL before ordering and use.

<https://www.azbil.com/products/factory/order.html>

Specifications are subject to change without notice.

The logo for Azbil Corporation, featuring the word "azbil" in a bold, lowercase, sans-serif font.

Azbil Corporation

Advanced Automation Company

1-12-2 Kawana, Fujisawa
Kanagawa 251-8522 Japan
URL: <https://www.azbil.com/>

1st edition: Feb. 2010
4th edition: Aug. 2023

No part of this publication may be reproduced or duplicated without the prior written permission of Azbil Corporation.