

Air-O-Motor

Spring Type Diaphragm Actuator

Model VA5

OVERVIEW

The Air-O-Motor is a pneumatic actuator. It accepts the pneumatic output of positioners or other control equipments, converts the pneumatic force into a mechanical force with the diaphragm, and let the diaphragm force balanced with the spring force, there by setting the valve position.

SPECIFICATIONS

Types

Action	Model Number
Direct	VA5D
Reverse	VA5R

1) Direct action

As the air pressure fed to the top chamber of the diaphragm case increases, the actuator stem moves downward.

2) Reverse action

As the air pressure fed to the bottom chamber of the diaphragm case increases, the actuator stem moves upward.

Material

- Diaphragm case
SS400
- Diaphragm
Cloth embedded chroloprene rubber
- Actuator stem
SUS403 stainless steel
- Yoke
FC200 (Optional: SCPH2)

Spring range

- 20 to 98 kPa {0.2 to 1.0 kgf/cm²}
- 40 to 120 kPa {0.4 to 1.2 kgf/cm²}
- 40 to 200 kPa {0.4 to 2.0 kgf/cm²}
- 80 to 240 kPa {0.8 to 2.4 kgf/cm²}

Supply pressure

120 to 270 kPa {1.2 to 2.8 kgf/cm²}

Stroke

37.5, 50, 75, 100 mm

Air connection

Rc 1/4 or 1/4NPT internal thread

Ambient temperature

-30°C to +70°C

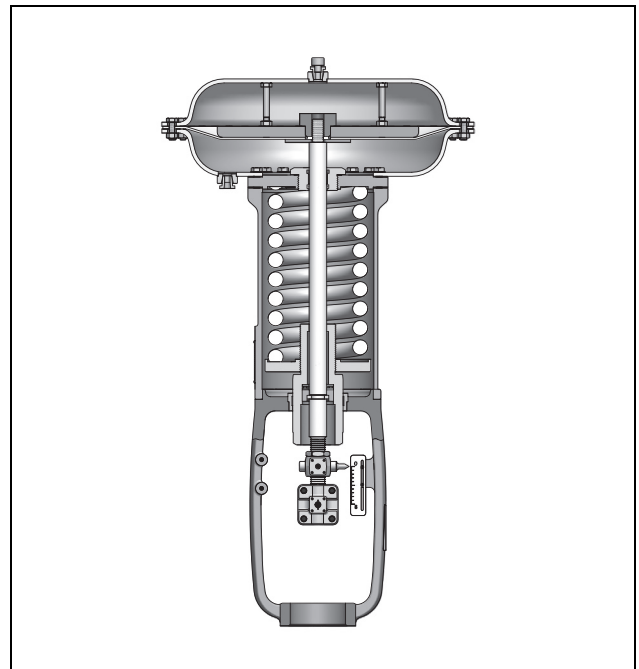

Optional accessories

Positioner*, pressure regulator with filter, hand wheel*, limit switch, solenoid valve, motion transmitter, booster relay, lock-up valve, and others.

Note) Accessories with the asterisk mark () are selected from the following types depending on the actuators to be combined.*

Actuator	Positioner		Hand wheel	
	P/P	I/P	Top	Side
VA5	HTP	AVP/HEP	THM	SHM

Performance

Output

Varies depending on utilized spring range and air supply pressure.

Accuracy

Refer to Table 1.

Dimensions and weight

Refer to Figure 1 and Table 2.

Finish

Blue (Munsell 10B5/10), silver or other specified colors.

Table 1 Hysteresis error and linearity

[Within %F.S.]

Item		Spring range	20 to 98 kPa {0.2 t o 1.0 kgf/cm ² }	80 to 240 kPa {0.8 to 2.4 kgf/cm ² }
Hysteresis error	Without positioner		3	-
	With positioner		1	1
Linearity	Without positioner		±5	-
	With positioner	HTP	±1	±1
		AVP/HEP	±1	±1

Note) When no positioner is provided, performance varies depending on the type of packing used.

DIMENSIONS

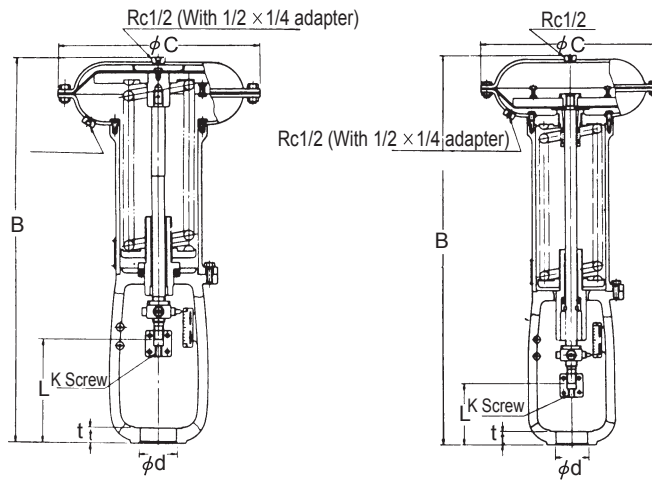

Figure 1 External dimensions

Table 2

Model no.	Maximum stroke (mm)	External dimensions (mm)						Diaphragm area (cm ²)	Max. volume of diaphragm chamber (cm ³)	Approx. weight (kg)
		L	B	φ d	t	K	φ C			
VA5D	75	268 *(238)	995	110	45	M28 × 1.5 or M24 × 1.5	620	1,300	25,300	160
	100	312	1195							220
VA5R	75	191	1105							185
	100	207	1325							255

Note) 1) Dimension "L" is the measurement when air supply pressure=0 kPa.
 2)*Dimension within () is for stem strokes of less than 50 mm.

Hand wheel

Generally, when there is no bypass valve, hand wheel of control valve is required for operation in air supply pressure failure. Two types of hand wheel are available, namely, the side-mounted and the top mounted hand wheel.

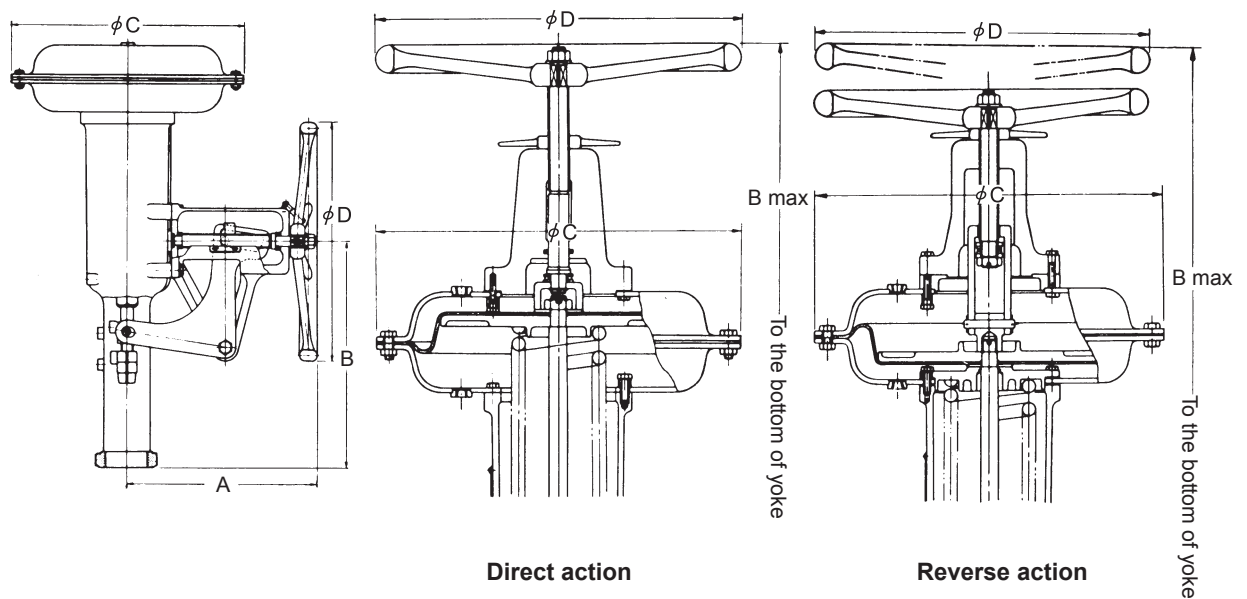

Figure 2 External Dimension, Approx. Weights & Others

Table 3 Side-mounted hand wheel

Model no.	Maximum stroke (mm)	External dimensions (mm)				Max. operating force required at hand wheel (N{kgf})	Approx. weights (Side hand wheel plus Air-O-Motor) (kg)
		A	B	ϕC	ϕD		
VA5D	75	500	591	620	570	550 {56}	201
	100	610	736			490 {50}	301
VA5R	75	500	591	620	570	550 {56}	226
	100	610	736			490 {50}	336

Table 4 Top-mounted hand wheel

Model no.	Maximum stroke (mm)	External dimensions (mm)			Max. operating force required at hand wheel (N{kgf})	Approx. weights (Top hand wheel plus Air-O-Motor) (kg)
		B max.	ϕC	ϕD		
VA5D	75	1460	620	570	550 {56}	212
	100	1660			640 {65}	280
VA5R	75	1610	620	570	550 {56}	237
	100	1828			640 {65}	315

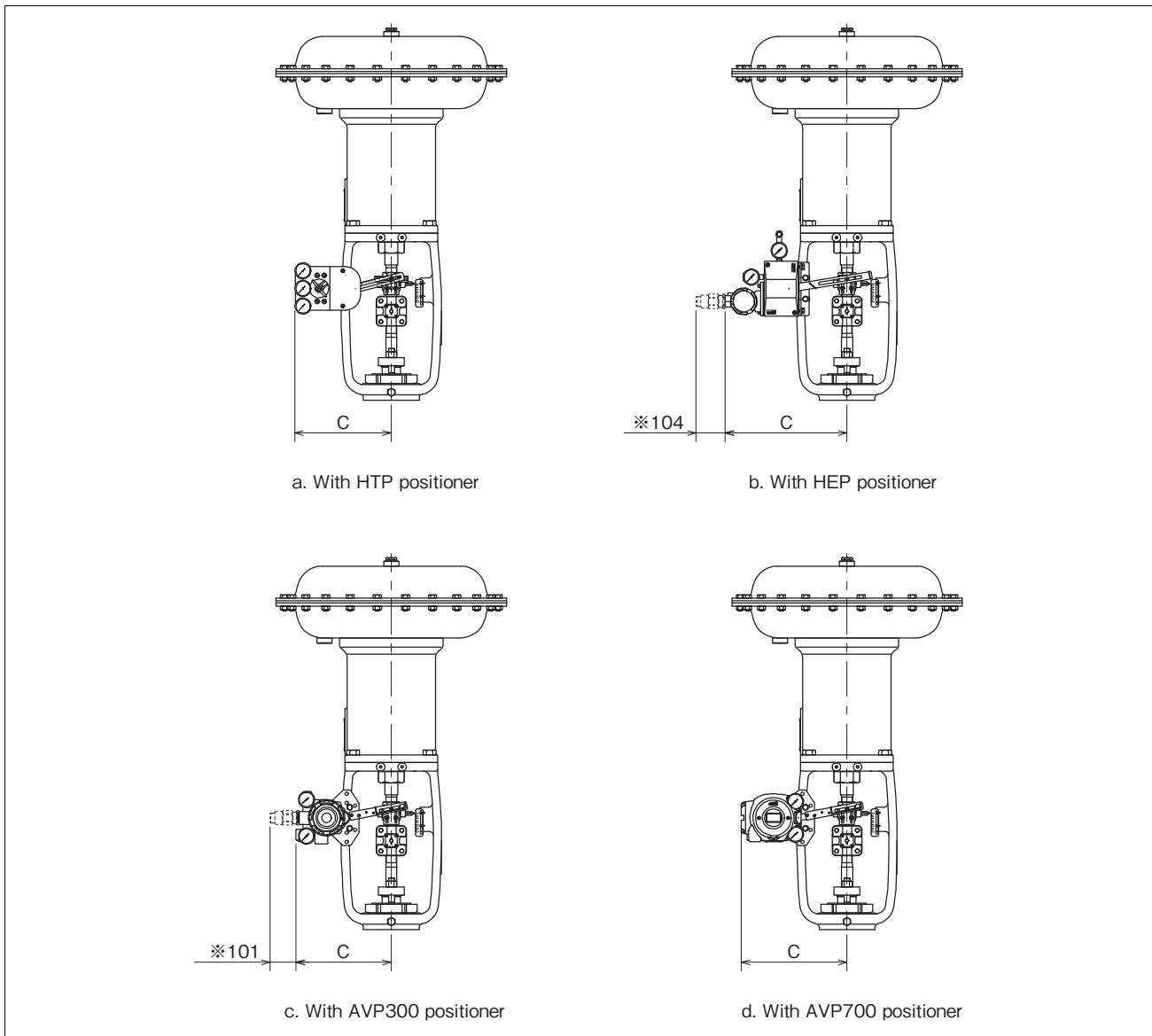

Figure 3 *Dimensions of actuator with positioner*

Table 5

Model No.	Stroke(mm)	P/P positioner		I/P positioner			
		HTP	HEP	AVP300 (KZ03 mounted on positioner)	AVP300 (KZ03 with bracket for separated mount)	AVP700 (KZ03 mounted on positioner)	AVP700 (KZ03 with bracket for separated mount)
VA5	75 or less	260	328	348	257	362	285
	100	270	336	356	265	370	293

Note) These dimensions are reference value.

Please, read 'Terms and Conditions' from following URL before the order and use.

<http://www.azbil.com/products/bi/order.html>

Specifications are subject to change without notice.

azbil

Azbil Corporation
Advanced Automation Company

1-12-2 Kawana, Fujisawa
Kanagawa 251-8522 Japan
URL: <http://www.azbil.com/>

7th Edition: Jun. 2015

No part of this publication may be reproduced or duplicated without the prior written permission of Azbil Corporation.