

Advanced Transmitter

Sanitary Differential Pressure/Pressure Transmitter

Model GTX35F/GTX60F

Model GTX35R/GTX40R

OVERVIEW

The Food and beverage industry and fermentation industry require equipment which satisfy stringent sanitary standards for the safety of their respective products.

Advanced Transmitter sanitary differential pressure/pressure transmitters, which are equipped with micro-processors, meet sanitary standards plus maintain high reproducibility and precise accuracy. These transmitters utilize a sanitary clamp for process connection which conforms to the ISO standard and makes for easy installation and easy maintenance.

By using a Smart Communicator, configuration of the transmitter (ranging, damping, output conformity, constant current output) and self-diagnostics are possible.

FEATURES

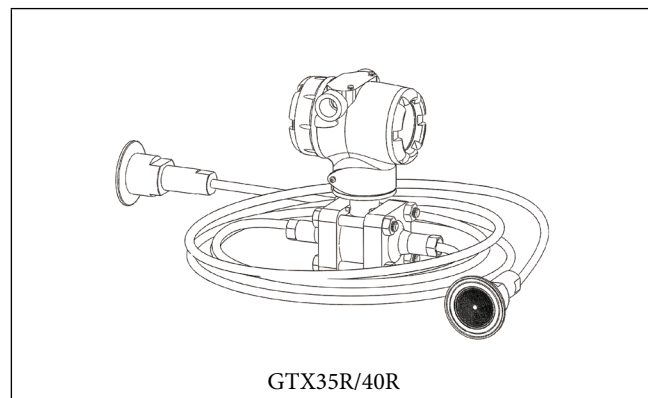
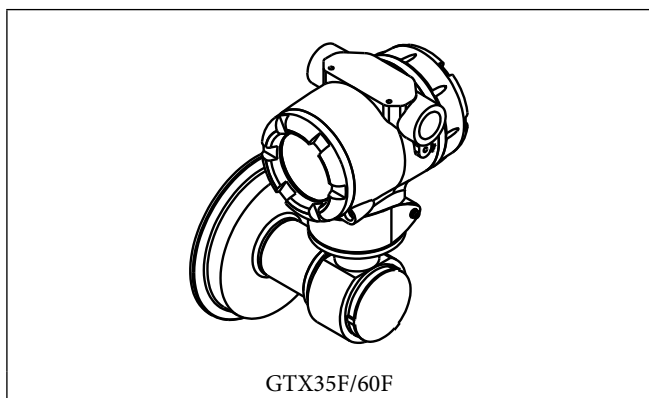

Replaceable diaphragm structure

The sanitary model GTX features a replaceable add on structure for its process interface. This allows a diaphragm to be quickly replaced.

ISO conform process interfaces

ISO or Tri101.6 clamp structure (Flush/Extended diaphragm) is employed for the process interface.

Broad measuring ranges

A broad range is covered by two models, the model GTX35F (2.5 to 100 kPa) and the model GTX60F (35 to 3500 kPa).

Integral digital indicator (optional)

The output can be checked in the field by using a digital indicator.

Various process interfaces

ISO or Tri51/76.1/101.6 clamp structures and ISO or Tri51 union nut structure are available for the process interface.

Ambient temperature compensation function (PAT. 1978534)

The model's ambient temperature compensation function calculates the specific gravity in regards to the ambient temperature and compensates the output. The shift in output by any ambient temperature change is dramatically reduced up to 1/10 of the shift without the compensation function.

Integral digital indicator (optional)

The output can be checked in the field with by using a digital indicator.

GASKET SELECTION

Silicone rubber and EPDM rubber gaskets and orings are available. Choose the appropriate material based on the following criteria.

Silicone rubber gasket

Since this gasket is resistant to solvents and chemicals, it is seldom damaged by polar organic compounds like alcohol, dilute acids, or dilute alkalis. During sterilization-in-place (SIP), hydrolysis or the like can damage the gasket. The gasket must be replaced regularly depending on the operating conditions or the application.

EPDM rubber gasket

Since this gasket is resistant to solvents and chemicals, it is seldom damaged by dilute alkalis. During sterilization-in-place (SIP), the gasket is generally less subject to damage by hydrolysis or the like than a silicone rubber one. The gasket must be replaced regularly depending on the operating conditions or the application.

PRODUCT APPROVALS [★]

FM Explosionproof for Division System/ Flameproof for Zone System (Code F1)

FM18US0129X

Explosionproof for Use in Class I, Division 1, Groups A, B, C and D T5; Dust-ignitionproof for Use in Class II, Division 1, Groups E, F and G, Class III Division 1, T5; $-40\text{ }^{\circ}\text{C} \leq T_{\text{amb}} \leq +85\text{ }^{\circ}\text{C}$; Flameproof for Use in Class I, Zone 0/1, AEx db IIC T5 Ga/Gb; $-30\text{ }^{\circ}\text{C} \leq T_{\text{amb}} \leq +80\text{ }^{\circ}\text{C}$; $-30\text{ }^{\circ}\text{C} \leq T_{\text{process}} \leq 100\text{ }^{\circ}\text{C}$; Hazardous (Classified) locations Indoor / Outdoor Enclosure Type 4X, IP67
Factory sealed, conduit seal not required for Division applications
Caution - Use supply wires suitable for 5 °C above surrounding ambient

FM Intrinsic Safety (Code F2)

FM18US0252X

Intrinsically Safe for Use in Class I, Division 1, Groups A, B, C and D; Class II, Division 1, Groups E, F and G; Class III, Division 1; $T_4 -40\text{ }^{\circ}\text{C} < T_{\text{amb}} < +60\text{ }^{\circ}\text{C}$; Class I, Zone 0, AEx ia IIC; $T_4\text{ Ga } -30\text{ }^{\circ}\text{C} < T_{\text{amb}} < +60\text{ }^{\circ}\text{C}$; $T_{\text{process}} = 105\text{ }^{\circ}\text{C}$
Hazardous (Classified) Locations; Indoor / Outdoor Enclosure TYPE 4X, IP67; 80395278, 80395279, and 80395280.
Entity Parameters: $V_{\text{max}} (U_i) = 30\text{ Volts}$, $I_{\text{max}} (I_i) = 100\text{ mA}$, $P_i = 1\text{ W}$, $C_i = 10\text{ nF}$, $L_i = 0.5\text{ mH}$

FM Nonincendive (Code F5)

FM18US0252X

Nonincendive, with Nonincendive Field Wiring Parameters, for Use in Class I, Division 2, Groups A, B, C and D, T4; Class I, Zone 2, Group IIC, T4;
Suitable for Class II & III, Division 2, Groups E, F and G, T4; $-40\text{ }^{\circ}\text{C} < T_{\text{amb}} < +60\text{ }^{\circ}\text{C}$; Hazardous (Classified) Locations; Indoor/Outdoor Enclosure TYPE 4X, IP67; 80395494.
Nonincendive Field Wiring Parameters: $V_{\text{max}} (U_i) = 30\text{ Volts}$, $C_i = 10\text{ nF}$, $L_i = 0.5\text{ mH}$

Combination of F1, F2 and F5 (Code F6)

ATEX Flameproof and Dust Certifications (Code A1)



II 1/2 G Ex db IIC T6 Ga/Gb $-30\text{ }^{\circ}\text{C} \leq T_{\text{amb}} \leq +75\text{ }^{\circ}\text{C}$ $T_{\text{process}} \leq 85\text{ }^{\circ}\text{C}$
II 1/2 G Ex db IIC T5 Ga/Gb $-30\text{ }^{\circ}\text{C} \leq T_{\text{amb}} \leq +80\text{ }^{\circ}\text{C}$ $T_{\text{process}} \leq 100\text{ }^{\circ}\text{C}$
II 1/2 G Ex db IIC T4 Ga/Gb $-30\text{ }^{\circ}\text{C} \leq T_{\text{amb}} \leq +80\text{ }^{\circ}\text{C}$ $T_{\text{process}} \leq 110\text{ }^{\circ}\text{C}$
II 2 D Ex tb IIIC T85 °C Db $-30\text{ }^{\circ}\text{C} \leq T_{\text{amb}} \leq +75\text{ }^{\circ}\text{C}$ $T_{\text{process}} \leq 85\text{ }^{\circ}\text{C}$
II 2 D Ex tb IIIC T100 °C Db $-30\text{ }^{\circ}\text{C} \leq T_{\text{amb}} \leq +75\text{ }^{\circ}\text{C}$ $T_{\text{process}} \leq 100\text{ }^{\circ}\text{C}$
II 2 D Ex tb IIIC T110 °C Db $-30\text{ }^{\circ}\text{C} \leq T_{\text{amb}} \leq +75\text{ }^{\circ}\text{C}$ $T_{\text{process}} \leq 110\text{ }^{\circ}\text{C}$
Caution - Use supply wires suitable for 5 °C above surrounding ambient

ATEX Intrinsic Safety and Dust certifications (Code A2)



II 1 G Ex ia IIC T4 Ga $-30\text{ }^{\circ}\text{C} \leq T_{\text{amb}} \leq +60\text{ }^{\circ}\text{C}$ $T_{\text{process}} = 105\text{ }^{\circ}\text{C}$
IP66/IP67
ELECTRICAL PARAMETERS: $U_i = 30\text{V}$, $I_i = 93\text{mA}$, $P_i = 1\text{W}$,
 $C_i = 5\text{nF}$, $L_i = 0.5\text{mH}$
II 2 D Ex ia IIIC T105 °C Db $-30\text{ }^{\circ}\text{C} \leq T_{\text{amb}} \leq +60\text{ }^{\circ}\text{C}$ $T_{\text{process}} = 105\text{ }^{\circ}\text{C}$ IP66/IP67
II 3 G Ex ic IIC T4 Gc $-30\text{ }^{\circ}\text{C} \leq T_{\text{amb}} \leq +60\text{ }^{\circ}\text{C}$ $T_{\text{process}} = 110\text{ }^{\circ}\text{C}$
IP66/IP67
ELECTRICAL PARAMETERS: $U_i = 30\text{V}$, $C_i = 5\text{nF}$, $L_i = 0.5\text{mH}$

NEPSI Flameproof and Dust Certifications (Code N1)

Ex d IIC T6 Gb; Ex tD A21 IP66/IP67 T85 °C $T_{\text{process}} = 80\text{ }^{\circ}\text{C}$;
 $-30\text{ }^{\circ}\text{C} \leq T_{\text{amb}} \leq +75\text{ }^{\circ}\text{C}$
Ex d IIC T5 Gb; Ex tD A21 IP66/IP67 T100 °C $T_{\text{process}} = 95\text{ }^{\circ}\text{C}$;
 $-30\text{ }^{\circ}\text{C} \leq T_{\text{amb}} \leq +80\text{ }^{\circ}\text{C}$
Ex d IIC T4 Gb; Ex tD A21 IP66/IP67 T115 °C $T_{\text{process}} = 110\text{ }^{\circ}\text{C}$;
 $-30\text{ }^{\circ}\text{C} \leq T_{\text{amb}} \leq +80\text{ }^{\circ}\text{C}$

NEPSI Intrinsic Safety Certification (Code N2)

Ex ia IIC T4 Ga $-30\text{ }^{\circ}\text{C} \leq T_{\text{amb}} \leq +60\text{ }^{\circ}\text{C}$ $T_{\text{process}} = 105\text{ }^{\circ}\text{C}$ IP66/IP67
Ex ia IIIC T105 °C Db $-30\text{ }^{\circ}\text{C} \leq T_{\text{amb}} \leq +60\text{ }^{\circ}\text{C}$ $T_{\text{process}} = 105\text{ }^{\circ}\text{C}$ IP66/IP67
Ex ic IIC T4 Gc $-30\text{ }^{\circ}\text{C} \leq T_{\text{amb}} \leq +60\text{ }^{\circ}\text{C}$ $T_{\text{process}} = 110\text{ }^{\circ}\text{C}$ IP66/IP67
ELECTRICAL PARAMETERS: $U_i = 30\text{V}$, $I_i = 93\text{mA}$, $P_i = 1\text{W}$,
 $C_i = 5\text{nF}$, $L_i = 0.5\text{mH}$
Use cable suitable for 5 °C above ambient temperature

IECEx Flameproof and Dust Certifications (Code E1)

Certificate No. IECEx KEM 08.0001 X

Ex db IIC T6 Ga/Gb $-30\text{ }^{\circ}\text{C} \leq T_{\text{amb}} \leq +75\text{ }^{\circ}\text{C}$ $T_{\text{process}} \leq 85\text{ }^{\circ}\text{C}$
Ex db IIC T5 Ga/Gb $-30\text{ }^{\circ}\text{C} \leq T_{\text{amb}} \leq +80\text{ }^{\circ}\text{C}$ $T_{\text{process}} \leq 100\text{ }^{\circ}\text{C}$
Ex db IIC T4 Ga/Gb $-30\text{ }^{\circ}\text{C} \leq T_{\text{amb}} \leq +80\text{ }^{\circ}\text{C}$ $T_{\text{process}} \leq 110\text{ }^{\circ}\text{C}$
Ex tb IIIC T85 °C Db $-30\text{ }^{\circ}\text{C} \leq T_{\text{amb}} \leq +75\text{ }^{\circ}\text{C}$ $T_{\text{process}} \leq 85\text{ }^{\circ}\text{C}$
Ex tb IIIC T100 °C Db $-30\text{ }^{\circ}\text{C} \leq T_{\text{amb}} \leq +75\text{ }^{\circ}\text{C}$ $T_{\text{process}} \leq 100\text{ }^{\circ}\text{C}$
Ex tb IIIC T110 °C Db $-30\text{ }^{\circ}\text{C} \leq T_{\text{amb}} \leq +75\text{ }^{\circ}\text{C}$ $T_{\text{process}} \leq 110\text{ }^{\circ}\text{C}$
Caution - Use supply wires suitable for 5 °C above surrounding ambient

IECEX Intrinsic Safety and Dust Certifications (Code E2)

Certificate No. IECEX KEM 07.0058 X

Ex ia IIC T4 Ga -30 °C≤T_{amb}≤+60 °C T_{process}=105 °C IP66/IP67

ELECTRICAL PARAMETERS: U_i=30V, I_i=93mA, P_i=1W,
C_i=5nF, L_i=0.5mH

Ex ia IIIC T105 °C Db -30 °C≤T_{amb}≤+60 °C T_{process}=105 °C
IP66/IP67

Ex ic IIC T4 Gc -30 °C≤T_{amb}≤+60 °C T_{process}=110 °C IP66/IP67

ELECTRICAL PARAMETERS: U_i=30V, C_i=5nF, L_i=0.5mH

KCs Flameproof (Code K1)

11-AV4BO-0323 (without option YD)

20-AV4BO-0357X (with option YD)

Ex d IIC T6 -30 °C≤T_{amb}≤+75 °C T_{process}=85 °C

Ex d IIC T5 -30 °C≤T_{amb}≤+80 °C T_{process}=100 °C

Ex d IIC T4 -30 °C≤T_{amb}≤+80 °C T_{process}=110 °C

18-AV4BO-0254X (without option YD)

20-AV4BO-0489X (with option YD)

Ex tD A21 T85 °C -30 °C≤T_{amb}≤+75 °C -30 °C≤T_{process}≤85 °C

Ex tD A21 T100 °C -30 °C≤T_{amb}≤+75 °C -30 °C≤T_{process}≤100 °C

Ex tD A21 T110 °C -30 °C≤T_{amb}≤+75 °C -30 °C≤T_{process}≤110 °C

TIIS Flameproof (Code J1)

Ex d IIC T4

Use cables with the maximum allowable temperature, 70 °C
in case ambient temperature excess 50 °C

TAIWAN Flameproof (Code T1)

Certificate No. (2015) 00113X

Ex db IIC T5 Gb -30 °C≤T_{amb}≤+80 °C T_{process}≤100 °C

Caution - Use supply wires suitable for 5 °C above surrounding
ambient.

TAIWAN Intrinsic Safety (Code T2)

Certificate No. (2016) 00227X

Ex ia IIC T4 Ga -30 °C≤T_{amb}≤+60 °C T_{process}≤105 °C IP66/IP67

ELECTRICAL PARAMETERS: U_i=30V, I_i=93mA, P_i=1W,
C_i=5nF, L_i=0.5mH

Ex ic IIC T4 Gc -30 °C≤T_{amb}≤+60 °C T_{process}≤110 °C IP66/IP67

ELECTRICAL PARAMETERS: U_i=30V, C_i=5nF, L_i=0.5mH

Please refer to specification, "SS2-GTX00Z-0100" for the
Fieldbus code below.

FM Intrinsic safety ia/ic FISCO and Fieldbus (Code F4)**FM Fieldbus Nonincendive (Code F7)****ATEX Intrinsic safety ia FISCO and Fieldbus (Code A4)****ATEX Intrinsic safety ic FISCO and Fieldbus (Code A7)****IECEX Intrinsic safety ia FISCO and Fieldbus (Code E4)****IECEX Intrinsic safety ic FISCO and Fieldbus (Code E7)****EMC Conformity [☆]**

EN 61326-1 (industrial electromagnetic environment)

EN 61326-2-3

SPECIFICATIONS COMMON

Type of protection

NEMA 3 and 4X
IEC IP66/67

Power Supply [☆]

12.5 to 42 V DC
Limited to 12.5 to 30 V DC for intrinsic safety, Nonincendive types

Power Supply voltage and load resistance characteristics [☆]

See Figure 3.
Limited to Load resistance: 250 to 1345 Ω for SFN or DE communication. 250 to 600 Ω for HART communication.
Power supply voltage: 12.5 to 30 V DC for intrinsic safety, Nonincendive types

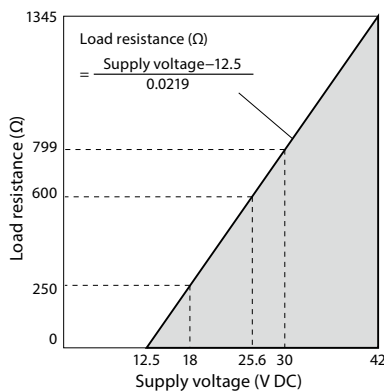

Figure 1. Supply voltage vs. load resistance characteristics

Note) For communication with a communicator, a load resistance of 250 Ω or more is necessary.

For negative pressure range

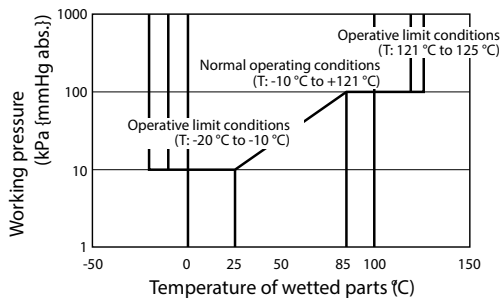

Figure 2. Propylene Glycol (Food additive)

Output [☆]

Analog output (4 to 20 mA DC) with DE protocol
Analog output (4 to 20 mA DC) with HART protocol
Digital output (DE protocol)

Output signal [☆]

3.6 to 21.6 mA
3.8 to 20.5 mA (NAMUR NE43 compliant)

Failure Alarm [☆]

Upper: 21.6 mA or more
Lower: 3.6 mA or less

Stability against supply voltage change

±0.005 % FS/V

Response time [☆]

Below 150 msec. (when damping time is set to 0 sec.)

Damping time [☆]

Selectable from 0 to 128 sec. (HART)
Selectable from 0 to 32 sec. in ten stages (SFN)

Zero Stability

±0.2 % of URL per 10 year

Lightning protection [☆]

Applicable Standards; IEC 61000-4-5
Peak value of current surge (80/20 μ sec.): 6000 A

Vibration characteristics

Amplitude: 0.42 mm / Frequency: 5 to 60 Hz
Acceleration: 29.4 m/s² (3G)/60 to 200 Hz

Shock characteristics

Acceleration 9.8 m/s² (1G)

Indicator

The digital LCD indicator (optional) shows the output in percentage or in engineering units. Range for engineering unit is from -99999 to 99999 when set at the factory, and from -19999 to 19999 when using the communicator. Specify the following items when placing order with engineering units,

- Pressure range
- Engineering unit of pressure
- Method of display, either linear or square-root.

These date may be set or changed using the communicator.

Paint

Standard: Baked acrylic paint
Corrosion-proof: Baked urethane paint

Color

Housing: Silver N-8.2
Cap: azbil bordeaux 2.5R 2.25/5

Weight

Approx. 5.9 kg (in case of ANSI 150# - 1-1/2 inches flange)

Grounding

Resistance 100 Ω max.

Mounting

Direct mounting on the process side

SPECIFICATIONS OPTIONAL

FEP protective film

Use FEP protective films when corrosive fluids are used or to avoid metal ions contact.

Working temperature range

0 to 110 °C

Working pressure range

Atmospheric pressure to flange rating (up to JIS10K, ANSI/JPI 150) (Not usable under negative pressure)

Oil free finish

The transmitter is shipped with oil-free wetted parts.

External zero/span adjustment function

The transmitter can be easily adjusted to zero or span in the field. Indicator must be selected to enable this option. Fieldbus type does not have span adjustment.

Conformance to SI units

We deliver transmitters set to any SI units as specified.

Safety Transmitter

Select this option to be used as a component of Safety Instrument System (SIS).

GTX_ _ _ is complied with IEC61508, certified according to Safety Integrity Level 2 (SIL-2)

This option is not applicable for FOUNDATION Fieldbus type, DE communication type, external zero/span adjustment (option A2), and Alarm output (option Q7).

Alarm Output (contact output)

Contact output is prepared as alarm output when alarm (Output Alarm/Sensor Temp. Alarm) condition is detected. It can be set to or Normally Close.

Contact output type: One open collector (NPN)

Contact rating: 30 V DC max., 30 mA DC max.

Residual voltage at output ON: 3.0 V max.

Operating mode: Normally Open (default)

Normally Close is not recommended.

When this option is selected, CHECK terminals for current check cannot be used.

This option is not applicable for FOUNDATION Fieldbus type, and with intrinsic safety, Nonincendive types.

Advanced diagnostics [★]

This option is applicable for FOUNDATION Fieldbus type. Refer to SS2-GTX00Z-0100.

Custom calibration

Calibrate for the specified pressure range at the factory.

Moisture-free finish (including oil-free finish)

Shipped with water content and oil content removed from the wetted part. (A small amount of fluorine oil is applied to vent/drain plugs in order to prevent sticking.)

Test report

Shows the results of having tested the appearance, input output characteristics, insulation resistance, dielectric strength, etc., of the transmitter.

Mill sheet

Shows data related to the chemical composition, heat treatment condition, and mechanical properties of the wetted part material.

Test report (with traceability certificate)

Comprised of three documents: a traceability diagram, a calibration certificate, and a test report.

Withstand pressure and air tight test (general-purpose use)

Shows the results of the wetted part withstand pressure test (10 minutes) and air tight test (10 minutes).

Strength calculation sheet

Shows the results of having calculated the strength of the meter body cover, flanges, and bolts.

Calculated the strength of the meter

body cover, flanges, and bolts.

TRANSMITTER HANDLING NOTES

To get the most from the performance this transmitter can offer, please use it properly noting the points mentioned below. Before using it, please read the Instruction Manual.

Transmitter installation notes

WARNING

- When installing the transmitter, ensure that gaskets do not protrude from connecting points into the process (such as adapter flange connection points and connecting pipes and flanges). Failure to do so may cause a leak of process fluid, resulting in harm from burns, etc. In addition, if the process fluid contains toxic substances, take safety measures such as wearing goggles and a mask to prevent contact with the skin and eyes and to prevent inhalation.
- Use the transmitter within the operating ranges stated in the specifications (for explosion-proofing, pressure rating, temperature, humidity, voltage, vibration, shock, mounting direction, atmosphere, etc.). Using the transmitter outside the operating conditions may cause device failure or fire, resulting in a harmful physical risk of burning or the like.
- When performing wiring work in explosion-proof areas, follow the work method specified in the explosion-proof guidelines.

CAUTION

- After installation, do not use the transmitter as a foothold or put your weight on it. Doing so may cause damage.
- Be careful not to hit the glass indicator with tools etc. This could break the glass and cause injury.
- The transmitter is heavy. Wear safety shoes and take care when installing it.
- Impact to transmitter can damage sensor module.

Wiring notes

WARNING

- To avoid shocks, do not perform electrical wiring work with wet hands or with live wires.

CAUTION

- Do wiring work properly in conformance with the specifications. Wiring mistakes may result in malfunction or irreparable damage to the instrument.
- Use a power supply that conforms to the specifications. Use of an improper power supply may result in malfunction or irreparable damage to the instrument.
- Use a power supply with overcurrent protection for this instrument.

Handling precautions for HART specification devices

- If you need to operate with a secondary host (HART communicator, etc.), set the communication interval of the primary host (DCS, device management system) to 8 seconds or more, or suspend communication from the primary host. If the primary host repeats HART communication within 8 seconds, the request from the secondary host may not be received (communication may not be possible).
- If electrical noise in the environment prevents HART communications with the host, take countermeasures such as separating the signal cables from the source of the noise, improving the grounding, changing to shielded signal cables, etc. Even if noise interferes with HART communications, the 4–20 mA analog signal will be unaffected and can be used for control.
- If this product is being operated in multidrop mode, there is a limit to the number of devices that can be used. If you are using multidrop mode, please consult with us.

SPECIFICATIONS - Sanitary flange ISO or Tri101.6 clamp connection**Measuring span / Setting range / Working pressure range / Overload resistant value**

Model	Measuring Span	Setting span	Working pressure range
GTX35F	2.5 to 100 kPa {10 to 400 inH ₂ O} {250 to 10,000 mmH ₂ O}	-100 to 100 kPa {-400 to +400 inH ₂ O} {-10,000 to 10,000 mmH ₂ O}	Up to the ISO clamp pressure rating (700 kPa {101 psi}{7 kgf/cm ² })
GTX60F	35 to 3500 kPa {5.1 to 508 psi} {0.70 to 35 kgf/cm ² }	-100 to 3500 kPa {-14.5 to +508 psi} {-1 to 35 kgf/cm ² }	

Process pipe connection

ISO or Tri101.6 clamp connection
(Flush diaphragm / Extended diaphragm type)

Materials

Flush diaphragm.....316L SST
Wetted parts.....316L SST
Center body.....316 SST
Transmitter case.....Aluminum alloy
Meter body cover....SUS304
GasketSilicone rubber or EPDM rubber
O-ringSilicone rubber or EPDM rubber

Fill fluid

Propylene Glycol (Food additive)
Specific gravity: 1.032

Working pressure range

10 kPa abs. {40 inH₂O abs}{1000 mmH₂O abs } up to the
ISO clamp pressure rating (700 kPa {101 psi}{7 kgf/cm²})
For negative pressure range, see Figure 2.

Ambient temperature range

-10 to +60 °C

Temperature ranges of wetted parts

-10 to +121 °C
150 °C, 60 min.

Note: The temperature of the center body should not exceed 110 °C

Temperature range for transportation and storage

-20 to +60 °C

Ambient humidity range

5 to 100% RH

Weight

Approx. 4 kg (4S flush diaphragm type)

Other specifications

Refer to common specifications.

Accuracy / temperature characteristics

Model	GTX35F	GTX60F
Accuracy	± 0.3% (χ ≥ 25 kPa) ± (0.15 + 0.15 × $\frac{25}{\chi}$) % (χ < 25 kPa)	± 0.2% (χ ≥ 350 kPa) ± (0.05 + 0.15 × $\frac{350}{\chi}$) % (χ < 350 kPa)
Ambient temperature characteristics Zero shift Change of 30 °C	± (0.25 + 0.5 × $\frac{25}{\chi}$) %	± (0.15 + 0.30 × $\frac{350}{\chi}$) %
Ambient temperature characteristics Combined shift Change of 30 °C	± 1.6% (χ ≥ 25 kPa) ± (1.0 + 0.6 × $\frac{25}{\chi}$) % (χ < 25 kPa)	± 0.7% (χ ≥ 350 kPa) ± (0.25 + 0.45 × $\frac{350}{\chi}$) % (χ < 350 kPa)

Shown for each item are the upper limit (URV)^{*1} and the lower limit (LRV)^{*2} of the calibration range or the percentage ratio of the maximum value of the span to χ (kPa).

*Note) *1: URV denotes the value for 100% (20 mA DC) output.*

**2: LRV denotes value for 0% (4 mA DC) output*

**3: Within a range of URV ≥ 0 and LRV ≥ 0*

MODEL SELECTIONS - Sanitary flange ISO or Tri101.6 clamp connection

Model GTX35F/ GTX60F - Sanitary service (Fill fluid: Propylene Glycol)

Model No.: GTX__F - Selection I (I II III IV V VI VII VIII IX X XI) - Selection II (I II III IV V VI) - Options

Basic Model No.

	Measuring span	2.5 to 100 kPa {10 to 400 inH ₂ O}	GTX35F
		35 to 3500 kPa {5.1 to 508 psi}	GTX60F

Selection I

I	Output	4 to 20 mA (SFN Communication)	A
		4 to 20 mA (HART5 Communication)	B
		FOUNDATION Fieldbus *1*2*3	C
		Digital output (DE communication)*4	D
		4 to 20 mA (HART7 Communication)	F
II	Fill Fluid	For sanitary service (Propylene Glycol)	3
III	Material (Meterbody cover, Vent/Drain plugs)	Meterbody cover	Vent / Drain plugs
		None	None (For sanitary model)
IV	Material (Centerbody)	Reference side	Wetted part of flange side
		316 SST	316L SST
V	Process connections of reference side	Open to atmosphere (Sanitary)	J
VI	Process installation of reference side	No connection	X
VII	Flange rating	ISO Clamp	S1
VIII	Flange size*5	ISO or Tri101.6 clamp	5
IX	Flange type	Flush type	A
		Length of Extended part 50 mm (O ring: Silicone rubber)	B
		Length of Extended part 100 mm (O ring: Silicone rubber)	C
		Length of Extended part 50 mm (O ring: EPDM)	N
		Length of Extended part 100 mm (O ring: EPDM)	P
X	Flange material/bolt and nut material	Flange	Bolt/nut
		No Flange / No bolt/nut (For open to atmosphere, Weld type)	6
XI	Gasket face finish	None	A

Note) *1. Not applicable for the combination with code Q1 "Safety Transmitter" and Q2 "NAMUR NE43 Compliant Output signal limits" of Option.

*2. In case code A of indicator is selected, code A2 of Option code should be selected.

*3. Not applicable for the combination with code YB "Assembled in China (for use in China)" and YD "Assembled in China (for use outside of China)" of Option.

*4. Not applicable for the combination with code A2 "With external Zero/Span adjustment", Q1 "Safety Transmitter", and Q2 "NAMUR NE43 Compliant Output signal limits" of Option.

*5 For this Flange size, Option YB or YD should be selected.

Model No.: GTX_ _F - Selection I (I II III IV V VI VII VIII IX X XI) - Selection II (I II III IV V VI) - Options

Selection II

Selection II		-	
I	Electrical connection	G1/2 *2 *10	1
		G1/2 THIS explosion proof with 1 cable gland attached *3 *10	3
		G1/2 THIS explosion proof with 2 cable gland attached *3 *10	4
		1/2 NPT, Watertight	A
		M20, Watertight *1	B
II	Explosion proof [★] *14 *15	None	XX
		FM Explosionproof for Division system/Flameproof for Zone system	F1
		FM Intrinsic safety	F2
		FM Intrinsic safety ia/ic FISCO and Fieldbus *8	F4
		FM Nonincendive	F5
		Combination of code F1, F2, and F5	F6
		FM Fieldbus Nonincendive *8	F7
		ATEX Flameproof	A1
		ATEX Intrinsic safety	A2
		ATEX Intrinsic safety ia FISCO and Fieldbus *8	A4
		ATEX Intrinsic safety ic FISCO and Fieldbus *8	A7
		IECEx Flameproof	E1
		IECEx Intrinsic safety	E2
		IECEx Intrinsic safety ia FISCO and Fieldbus *8	E4
		IECEx Intrinsic safety ic FISCO and Fieldbus *8	E7
		NEPSI Flameproof	N1
		NEPSI Intrinsic safety	N2
		THIS Flameproof *5 *6	J1
KCs Flameproof *6	K1		
TAIWAN Flameproof	T1		
TAIWAN Intrinsic Safety	T2		
III	Indicator	None	X
		With indicator *7	A
IV	Paint *12	Standard	X
		None (316 stainless steel housing) *4	E
		Corrosion-proof (Urethane)	H
V	Failure alarm	Upper limit of output at abnormal condition	A
		Lower limit of output at abnormal condition	B
		None (for FOUNDATION Fieldbus) *8	X
VI	Mounting bracket	None	X

Note) *1. Not applicable for the combination with code F1, F6 of Explosion proof.

*2. Code XX of Explosion proof should be selected.

*3. Code J1 of Explosion proof should be selected.

*4. Not applicable for combination with code 1,3,4 of Electrical connection.

*5. 3 or 4 of Electrical connection should be selected.

*6. Not applicable for the combination with code E of Paint.

*7. In case the code C "FOUNDATION Fieldbus communication" of output is selected, code A2 of Option code should be selected.

*8. In case this code is selected, code C of Output should be selected.

*9. In case code X or H is selected, the material of transmitter case is aluminum alloy.

*10. Not applicable for the combination with code YB "Assembled in China (for use in China)" and YD "Assembled in China (for use outside of China)" of Option.

*12. In case code X or H is selected, the material of transmitter case is aluminum alloy.

*14. For FOUNDATION Fieldbus type. Refer to SS2-GTX00Z-0100.

*15. For option code YB "Assembled in China (for use in China)" and YD "Assembled in China (for use outside of China)" selected, only the following codes can be selected.

YB: XX, N1, N2

YD: XX, F1, F2, F5, F6, A1, A2, E1, E2, T1, T2, K1

Option	-
No options	XX
With external Zero/Span adjustment *6*7	A2
ISO Clamp with Gasket	H2
ISO Clamp	H3
ISO Gasket (Silicorn)	H4
Extended type Tank spud 1 pc.	H5
ISO Clamp with Gasket (EPDM)	H7
Gasket for ISO Clamp (EPDM)	H8
Oil and water free finish	K1
Oil free finish *1	K3
Electrolytic polishing	L7
Passivate Treatment	L8
Safety Transmitter *7*9*12	Q1
NAMUR NE43 Compliant Output Signal Limits: 3.8 to 20.5 mA (Output 21.6 mA/selected upper limit, 3.6 mA/selected lower limit) *7*9	Q2
Alarm Output (contact output) *8*9	Q7
Advanced diagnostics *10	Q8
Custom calibration	R1
Test report	T1
Mill certificate	T2
Traceability certificate *11	T4
Non SI Unit	W1
Safety label for Taiwan	Y2
Assembled in China (for use in China)	YB
Assembled in China (for use outside of China)	YD

Note) *1. No need to select when Fill Fluid code H, or J is selected.

*2. Not applicable for the combination with code A, or B of Process installation.

*3. Not applicable for the combination with code F1, F6 of Explosion proof.

*4. Not applicable for any Explosion proof. Please select code XX "None" of Explosion proof.

*5. Not applicable for the combination with code B "M20, Watertight" electrical connection.

*6. Not applicable for the combination with code X "None" of Indicator. Please select "With indicator".

*7. Not applicable for the combination with code D "Digital output (DE communication)" of output.

*8. Not applicable for the combination with code F2, F5, F6, N2, C2, E2, and A2 of Explosion proof.

*9. Not applicable for the combination with code C "Digital output (FOUNDATION Fieldbus communication)" of output.

*10. Not applicable for the combination with code A "4 to 20 mA (SFN Communication)", B "4 to 20 mA (HART5 Communication)", and D "Digital output (DE communication)" of output.

*11. Not applicable for the combination with code YB "Assembled in China (for use in China)" and YD "Assembled in China (for use outside of China)" of Option.

*12. Not applicable for the combination with code A2, or Q7 of Option.

DIMENSIONS - Sanitary flange ISO or Tri101.6 clamp connection

Flush flange type

unit: mm

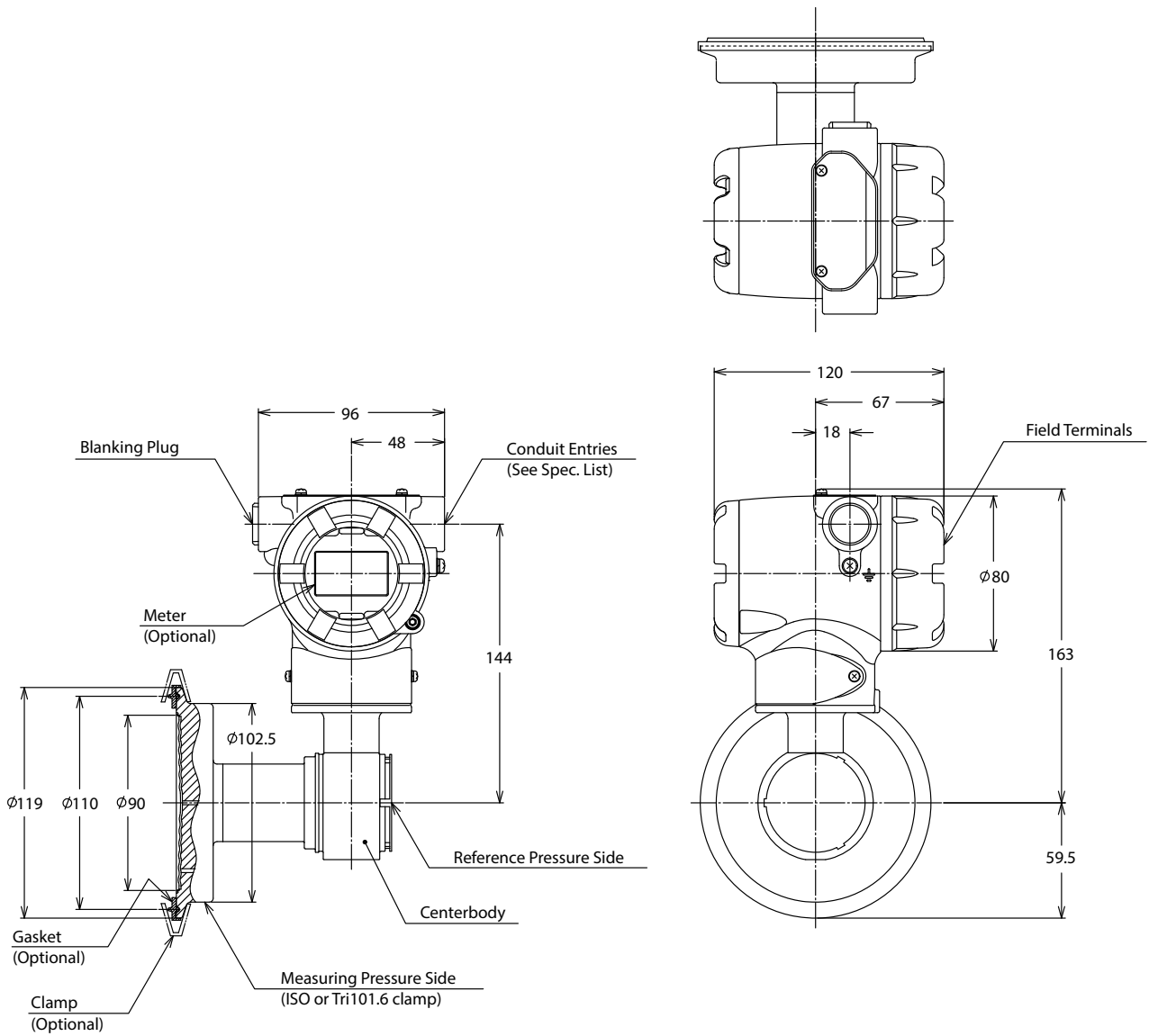

SPECIFICATIONS - Sanitary remote-sealed diaphragm ISO or Tri51/76.1/101.6 clamp connection

Measuring span / Setting range / Working pressure range / Overload resistant value

Model	Measuring Span	Setting span	Working pressure range
GTX35R	2.5 to 100 kPa {10 to 400 inH ₂ O} {250 to 10,000 mmH ₂ O}	-100 to 100 kPa {-400 to +400 inH ₂ O} {-10,000 to 10,000 mmH ₂ O}	Up to the ISO clamp pressure rating (700 kPa {101 psi}{7 kgf/cm ² })
GTX40R	35 to 700 kPa {5.1 to 101 psi} {0.35 to 7 kgf/cm ² }	-100 to 700 kPa {-14.5 to +101 psi} {-1 to 7 kgf/cm ² }	

Process pipe connection

ISO or Tri51/76.1/101.6 clamp connection
(Flush diaphragm / Extended diaphragm type)

Materials

Flush diaphragm.....316L SST
Wetted parts.....316L SST
Center body.....316 SST
Transmitter case.....Aluminum alloy
Meter body coverSCS13
Capillary tube coating...Olefin
GasketSilicone rubber or EPDM rubber
O-ringSilicone rubber or EPDM rubber

Fill fluid

Propylene Glycol (Food additive)
Specific gravity: 1.032

Working pressure range

10 kPa abs. {40 inH₂O abs}{1000 mmH₂O abs } up to the ISO clamp pressure rating (700 kPa {101 psi}{7 kgf/cm²})
For negative pressure range, see Figure 2.

Ambient temperature range

-10 to +60 °C

Temperature ranges of wetted parts

-10 to +121 °C (Sterilization)
150 °C, 60 min. (Steam wash)

Note: The temperature of the transmitter body should not exceed 110 °C

Temperature range for transportation and storage

-20 to +60 °C

Ambient humidity range

5 to 100% RH

Weight

Approx. 6.7 kg (2S flush clamp connection and capillary 3 m)

Other specifications

Refer to common specifications.

Accuracy / temperature characteristics

Model	GTX35R		GTX40R		
Accuracy	Linear out:	$\pm 0.3\%$ ($\chi \geq 12.5$ kPa)	Linear out:	$\pm 0.2\%$ ($\chi \geq 210$ kPa)	
		$\pm (0.15 + 0.15 \times \frac{12.5}{\chi}) \%$ ($\chi < 12.5$ kPa)		$\pm (0.05 + 0.15 \times \frac{210}{\chi}) \%$ ($\chi < 210$ kPa)	
Temperature characteristics (Shift from the set range) Change of 10 °C	76.1	Zero shift:	51	Zero shift:	
		$\pm 0.14\%$ ($\chi \geq 25$ kPa)			$\pm (0.05 + 0.09 \times \frac{210}{\chi}) \%$ ($\chi \geq 210$ kPa)
	101.6	$\pm (0.14 \times \frac{25}{\chi}) \%$ ($\chi < 25$ kPa)	76.1	Combined shift:	$\pm 0.51\%$ ($\chi \geq 210$ kPa)
		Combined shift:			
	51	$\pm 0.3\%$ ($\chi \geq 25$ kPa)	101.6	Zero shift:	$\pm 0.36\%$ ($\chi \geq 25$ kPa)
		$\pm (0.3 \times \frac{25}{\chi}) \%$ ($\chi < 25$ kPa)			
51	Zero shift:	51	Combined shift:	$\pm 2.18\%$ ($\chi \geq 25$ kPa)	
	$\pm 0.36\%$ ($\chi \geq 25$ kPa)				$\pm (2.18 \times \frac{25}{\chi}) \%$ ($\chi < 25$ kPa)
101.6	$\pm (0.36 \times \frac{25}{\chi}) \%$ ($\chi < 25$ kPa)	76.1	Zero shift:	$\pm 0.36\%$ ($\chi \geq 25$ kPa)	
	Combined shift:				$\pm (0.36 \times \frac{25}{\chi}) \%$ ($\chi < 25$ kPa)
51	$\pm 2.18\%$ ($\chi \geq 25$ kPa)	101.6	Combined shift:	$\pm 2.18\%$ ($\chi \geq 25$ kPa)	
	$\pm (2.18 \times \frac{25}{\chi}) \%$ ($\chi < 25$ kPa)				$\pm (2.18 \times \frac{25}{\chi}) \%$ ($\chi < 25$ kPa)

Shown for each item are the upper limit (URV)^{*1} and the lower limit (LRV)^{*2} of the calibration range or the percentage ratio of the maximum value of the span to χ (kPa).

*Note) *1: URV denotes the value for 100% (20 mA DC) output.*

**2: LRV denotes value for 0% (4 mA DC) output*

**3: Within a range of URV ≥ 0 and LRV ≥ 0*

SPECIFICATIONS - Sanitary remote-sealed diaphragm ISO or Tri51 union nut connection

Measuring span / Setting range / Working pressure range / Overload resistant value

Model	Measuring Span	Setting span	Working pressure range
GTX35R	2.5 to 100 kPa {10 to 400 inH ₂ O} {250 to 10,000 mmH ₂ O}	-100 to 100 kPa {-400 to +400 inH ₂ O} {-10,000 to 10,000 mmH ₂ O}	Up to the ISO clamp pressure rating (700 kPa {101 psi}{7 kgf/cm ² })
GTX40R	35 to 700 kPa {5.1 to 101 psi} {0.35 to 7 kgf/cm ² }	-100 to 700 kPa {-14.5 to +101 psi} {-1 to 7 kgf/cm ² }	

Process pipe connection

ISO or Tri51 union nut connection (Flush diaphragm)

Materials

- Diaphragm.....316L SST
- Wetted parts.....316L SST
- Center body316 SST
- Transmitter case.....Aluminum alloy
- Meter body coverSUSF304
- Capillary tube coating ...Olefin
- GasketSilicone rubber or EPDM rubber
- O-ring.....Silicone rubber or EPDM rubber

Fill fluid

Polyleneglycol (Food additive)
Specific gravity: 1.032

Working pressure range

10 kPa abs. (1000 mmH₂O abs.) up to the ISO clamp pressure rating (700 kPa {7 kgf/cm²})
For negative pressure range, see Figure 2.

Ambient temperature range

-10 to +60 °C

Temperature ranges of wetted parts

-10 to +121 °C (Sterilization)
150 °C, 60 min. (Steam wash)
Note: The temperature of the transmitter body should not exceed 110 °C

Temperature range for transportation and storage

-20 to +60 °C

Ambient humidity range

5 to 100% RH

Weight

Approx. 7.5 kg (2S cap nut connection and capillary 3 m)

Other specifications

Refer to common specifications.

Accuracy / temperature characteristics

Model	GTX35R		GTX40R	
Accuracy	Linear out:	± 0.3% (χ ≥ 12.5 kPa) ± (0.3 × $\frac{12.5}{\chi}$) % (χ < 12.5 kPa)	Linear out:	± 0.2% (χ ≥ 210 kPa) ± (0.05 + 0.15 × $\frac{210}{\chi}$) % (χ < 210 kPa)
Temperature characteristics (Shift from the set range) Change of 10 °C	Zero shift:	± 0.36% (χ ≥ 25 kPa) ± (0.36 × $\frac{25}{\chi}$) % (χ < 25 kPa)	Zero shift:	± (0.05 + 0.09 × $\frac{210}{\chi}$) %
	Combined shift:	± 2.18% (χ ≥ 25 kPa) ± (2.18 × $\frac{25}{\chi}$) % (χ < 25 kPa)	Combined shift:	± 0.51% (χ ≥ 210 kPa) ± (0.4 + 0.11 × $\frac{210}{\chi}$) % (χ < 210 kPa)

Shown for each item are the upper limit (URV) *1 and the lower limit (LRV) *2 of the calibration range or the percentage ratio of the maximum value of the span to χ (kPa).

*Note) *1: URV denotes the value for 100% (20 mA DC) output.*

**2: LRV denotes value for 0% (4 mA DC) output*

**3: Within a range of URV ≥ 0 and LRV ≥ 0*

MODEL SELECTIONS - Sanitary remote-sealed diaphragm ISO or Tri51/76.1/101.6 clamp connection ISO or Tri51 union nut connection

Model GTX35R/GTX40R - Sanitary service (Fill fluid: Propylene Glycol)

Model No.: GTX__R - Selection I (I II III IV V VI VII VIII IX) - Selection II (I II III IV V VI) - Options

Basic Model No.

Measuring span	2.5 to 100 kPa {10 to 400 inH ₂ O}	GTX35R	
	35 to 700 kPa {5.1 to 101 psi}	GTX40R	

Selection I

I	Output	4 to 20 mA (SFN Communication)	A	
		4 to 20 mA (HART5 Communication)	B	
		FOUNDATION Fieldbus ^{*1 *2 *3}	C	
		Digital output (DE communication) ^{*4}	D	
		4 to 20mA (HART7 Communication)	F	
II	Fill Fluid	For sanitary service (Propylene Glycol)	3	
III	Wetted parts material	316L SST		D
IV	Flange rating	ISO Clamp		S1
V	Flange size ^{*5}	ISO or Tri51 clamp		3
		ISO or Tri76.1 clamp		4
		ISO or Tri101.6 clamp		5
		ISO or Tri51 union nut		7
VI	Flange type	Flush type		A
		Length of Extended part 50 mm (O ring: Silicone rubber)		B
		Length of Extended part 100 mm (O ring: Silicone rubber)		C
		Length of Extended part 50 mm (O ring: EPDM)		N
		Length of Extended part 100 mm (O ring: EPDM)		P
VII	Flange material/bolt and nut material	Flange	Bolt/nut	
		No Flange	304 SST	1
		No Flange	630 SST	3
		No Flange	Carbon steel	4
VIII	Gasket face finish	None		A
IX	Capillary length	2 m (with Olefin Cover)		A2
		3 m (with Olefin Cover)		A3
		4 m (with Olefin Cover)		A4
		5 m (with Olefin Cover)		A5

Note) *1. Not applicable for the combination with code Q1 "Safety Transmitter" and Q2 "NAMUR NE43 Compliant Output signal limits" of Option.

*2. In case code A of indicator is selected, code A2 of Option code should be selected.

*3. Not applicable for the combination with code YB "Assembled in China (for use in China)" and YD "Assembled in China (for use outside of China)" of Option.

*4. Not applicable for the combination with code A2 "With external Zero/Span adjustment", Q1 "Safety Transmitter", and Q2 "NAMUR NE43 Compliant Output signal limits" of Option.

*5. For this Flange size, Option YB or YD should be selected.

Model No.: GTX_ _R - Selection I (I II III IV V VI VII VIII IX) - Selection II (I II III IV V VI) - Option

Selection II

I	Electrical connection	G1/2 *2 *11	1
		G1/2 TIIS explosion proof with 1 cable gland attached *3 *11	3
		G1/2 TIIS explosion proof with 2 cable gland attached *3 *11	4
		1/2 NPT, Watertight	A
		M20, Watertight *1	B
II	Explosion proof [★] *14 *15	None	XX
		FM Explosionproof for Division system/Flameproof for Zone system	F1
		FM Intrinsic safety	F2
		FM Intrinsic safety ia/ic FISCO and Fieldbus *8	F4
		FM Nonincendive	F5
		Combination of code F1, F2, and F5	F6
		FM Fieldbus Nonincendive *8	F7
		ATEX Flameproof	A1
		ATEX Intrinsic safety	A2
		ATEX Intrinsic safety ia FISCO and Fieldbus *8	A4
		ATEX Intrinsic safety ic FISCO and Fieldbus *8	A7
		IECEx Flameproof	E1
		IECEx Intrinsic safety	E2
		IECEx Intrinsic safety ia FISCO and Fieldbus *8	E4
		IECEx Intrinsic safety ic FISCO and Fieldbus *8	E7
		NEPSI Flameproof	N1
		NEPSI Intrinsic safety	N2
TIIS Flameproof *5 *6	J1		
KCs Flameproof *6	K1		
TAIWAN Flameproof	T1		
TAIWAN Intrinsic Safety	T2		
III	Indicator	None	X
		With indicator *7	A
IV	Paint *12	Standard	X
		None (316 stainless steel housing) *4	E
		Corrosion-proof (Urethane)	H
V	Failure alarm	Upper limit of output at abnormal condition	A
		Lower limit of output at abnormal condition	B
		None (for FOUNDATION Fieldbus) *8	X
VI	Mounting bracket	None	X
		304 SST (Flat Form)	6
		Direct mounting kit *9	D

Note) *1. Not applicable for the combination with code F1, F6 of Explosion proof.

*2. Code XX of Explosion proof should be selected.

*3. Code J1 of Explosion proof should be selected.

*4. Not applicable for combination with code 1,3,4 of Electrical connection.

*5. 3 or 4 of Electrical connection should be selected.

*6. Not applicable for the combination with code E of Paint.

*7. In case the code C "FOUNDATION Fieldbus communication" of output is selected, code A2 of Option code should be selected.

*8. In case this code is selected, code C of Output should be selected.

*9. Not applicable for the combination with B, C, or D of Fill Fluid.

*10. In case code X or H is selected, the material of transmitter case is aluminum alloy.

*11. Not applicable for the combination with code YB "Assembled in China (for use in China)" and YD "Assembled in China (for use outside of China)" of Option.

*12. In case code X or H is selected, the material of transmitter case is aluminum alloy.

*14. For FOUNDATION Fieldbus type. Refer to SS2-GTX00Z-0100.

*15. For option code YB "Assembled in China (for use in China)" and YD "Assembled in China (for use outside of China)" selected, only the following codes can be selected.

YB : XX, N1, N2

YD : XX, F1, F2, F5, F6, A1, A2, E1, E2, T1, T2, K1

Option	-
No options	XX
With external Zero/Span adjustment *6*7	A2
ISO Clamp with Gasket	H2
ISO Clamp	H3
ISO Gasket (Silicorn)	H4
Extended type Tank spud 1 pc.	H5
Extended type Tank spud 2 pc.	H6
ISO Clamp with Gasket (EPDM)	H7
Gasket for ISO Clamp (EPDM)	H8
Oil and water free finish	K1
Oil free finish *1	K3
Electrolytic polishing	L7
Passivate Treatment	L8
Safety Transmitter *7*9*12	Q1
NAMUR NE43 Compliant Output Signal Limits: 3.8 to 20.5 mA (Output 21.6 mA/selected upper limit, 3.6 mA/selected lower limit) *7*9	Q2
Alarm Output (contact output) *8*9	Q7
Advanced diagnostics *10	Q8
Custom calibration	R1
Test report	T1
Mill certificate	T2
Traceability certificate *11	T4
Non SI Unit	W1
Safety label for Taiwan	Y2
Assembled in China (for use in China)	YB
Assembled in China (for use outside of China)	YD

Note) *1. No need to select when Fill Fluid code H, or J is selected.

*2. Not applicable for the combination with code A, or B of Process installation.

*3. Not applicable for the combination with code F1, F6 of Explosion proof.

*4. Not applicable for any Explosion proof. Please select code XX "None" of Explosion proof.

*5. Not applicable for the combination with code B "M20, Watertight" electrical connection.

*6. Not applicable for the combination with code X "None" of Indicator. Please select "With indicator".

*7. Not applicable for the combination with code D "Digital output (DE communication)" of output.

*8. Not applicable for the combination with code F2, F5, F6, N2, C2, E2, and A2 of Explosion proof.

*9. Not applicable for the combination with code C "Digital output (FOUNDATION Fieldbus communication)" of output.

*10. Not applicable for the combination with code A "4 to 20 mA (SFN Communication)", B "4 to 20 mA (HART5 Communication)", and D "Digital output (DE communication)" of output.

*11. Not applicable for the combination with code YB "Assembled in China (for use in China)" and YD "Assembled in China (for use outside of China)" of Option.

*12. Not applicable for the combination with code A2, or Q7 of Option.

DIMENSIONS - Sanitary remote-sealed diaphragm ISO or Tri51/76.1/101.6 clamp connection

DIMENSIONAL DRAWING

unit: mm

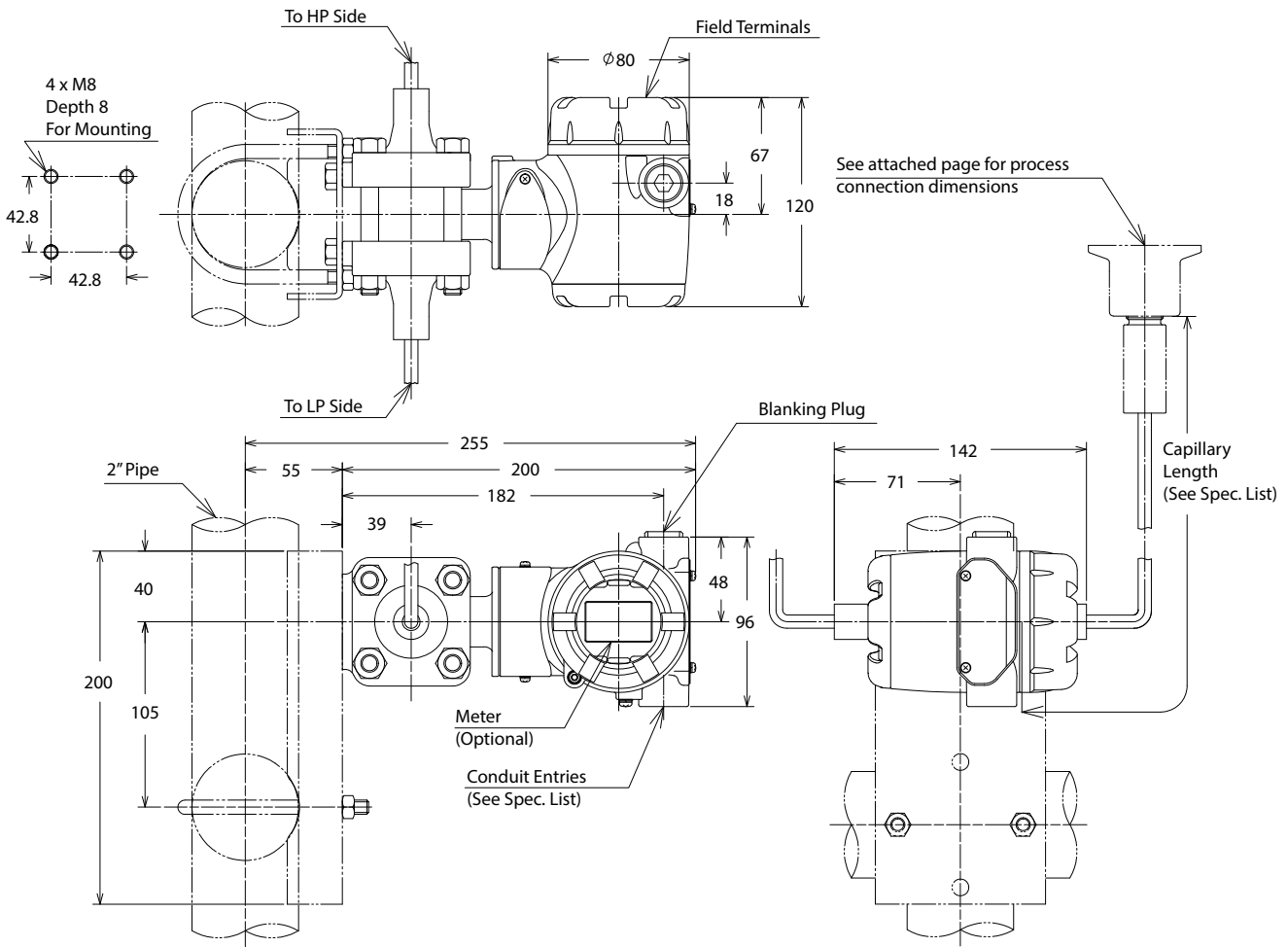

DIMENSIONS - Sanitary remote-sealed diaphragm ISO or Tri51 union nut connection

Dimensions

unit: mm

Flush Type

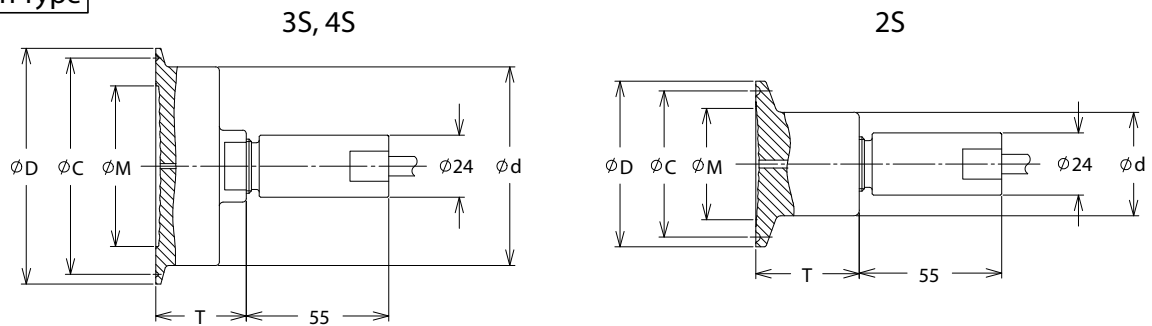

Dimensions

CODE No.			Ferrule Size	φD	φd	φC	φM	T
Standard	Size	Type						
S1/T1	5	A	IDF 4S	119	102.5	110	90	34
	4		IDF 3S	91	76.7	83.5	62	34
	3		IDF 2S	64	40	56.5	43	40

Extended Type Tank Spud

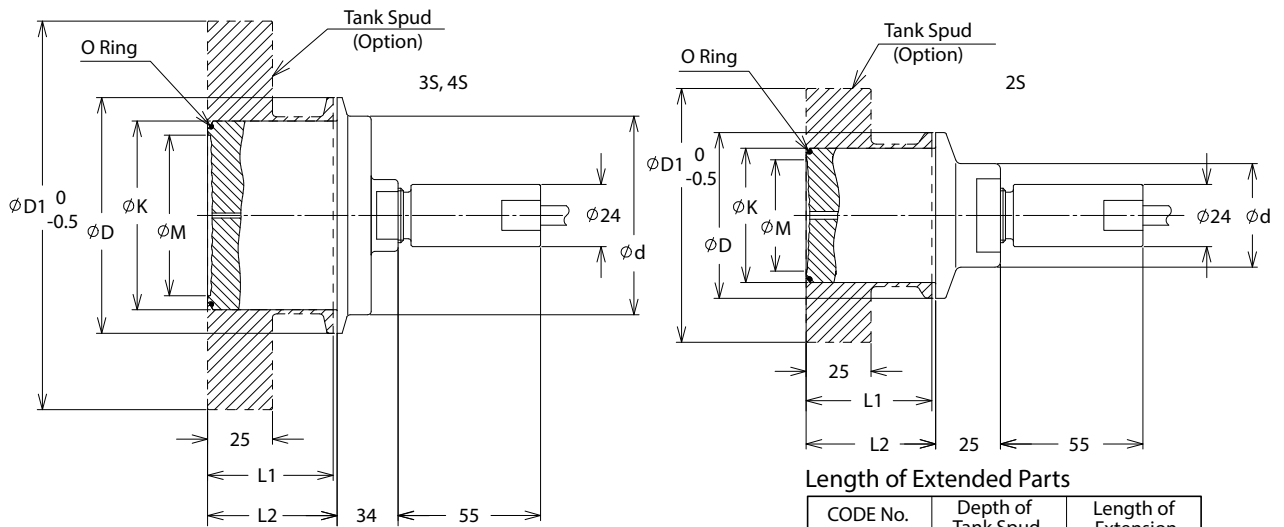

Length of Extended Parts

CODE No.		Depth of Tank Spud (L1)	Length of Extension (L2)
Type	Size		
B	5	50	51
	4		
	3		
C	5	100	101.5
	4		
	3		

Dimensions

CODE No.		Ferrule Size	φD	φd	φK	φM	Tank Spud Dim. φD1
Standard	Size						
S1/T1	5	IDF 4S	119	102.5	101.5	90	200
	4	IDF 3S	91	76.7	72.9	62	150
	3	IDF 2S	64	40	51.8	43	98

Hexagon Nut Type

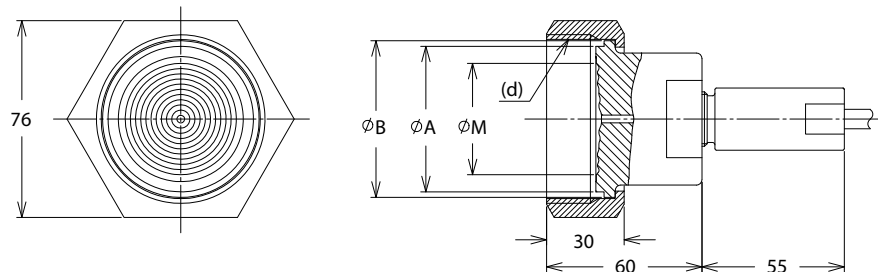

Dimensions

CODE No.		Nominal Size (d)	D	φM	φA	φB
Standard	Size					
S1/T1	7	IDF 2S	76	43	56.2	60.5

HART® is a registered trademark of the FieldComm Group.

FOUNDATION™ is a trademark of the FieldComm Group.

Please read "Terms and Conditions" from the following URL
before ordering and use.

<https://www.azbil.com/products/factory/order.html>

Specifications are subject to change without notice.

The logo for Azbil Corporation, featuring the word "azbil" in a bold, lowercase, sans-serif font.

Azbil Corporation
Advanced Automation Company

1-12-2 Kawana, Fujisawa
Kanagawa 251-8522 Japan
URL: <https://www.azbil.com/>

1st edition: Dec. 2020
5th edition: Apr. 2023

*No part of this publication may be reproduced or duplicated
without the prior written permission of Azbil Corporation.*