

# MagneW PLUS+

## Electromagnetic Flowmeter

### Open channel Flowmeter Detector

Model NNK150/951

#### OVERVIEW

The MagneW PLUS+ Electromagnetic Flowmeter is submersible type of flowmeter mainly used for flow rate measurement in open or closed channels. This flowmeter is simple in operating principle and easy to install but provides high measuring accuracy. These features are unattainable with other traditional electromagnetic flowmeters. The following out-standing features of the MagneW Flowmeter come from the square-wave excitation system.

#### FEATURES

- The detector can also be easily installed on any gate of an existing water channel. The channel may be an open or close type with rectangular or circular cross section.
- The construction is simple, having no moving parts. The flowmeters have sturdy resistance against staining, clogging or corroding if a fluid contains suspensions or adherents.
- The flow signal is linear, having a high measuring accuracy from 100% down to zero flow rate. Stable measurement can be done even when the channel is affected by the tide.
- A wide measuring range of 0 - 0.3 to 0 - 10 m/sec. can be covered. Still larger flows can be measured at the same water head by installing dummy detectors in parallel with the detector which are of the same physical dimensions.
- If the weir cannot be installed on the downstream of the detector, the weir with an elbow flange is conveniently used.
- The elbow flange is covered with a cover (optional), realizing expand- ability from a small to large flow rate measurement.
- The detector body is made of plastics, resulting in light and corrosion resistant structure.
- Installation is simple, greatly reducing the cost and time for the engineering work. The detector and the converter can be connected with one 4-core cable for signals and excitation.

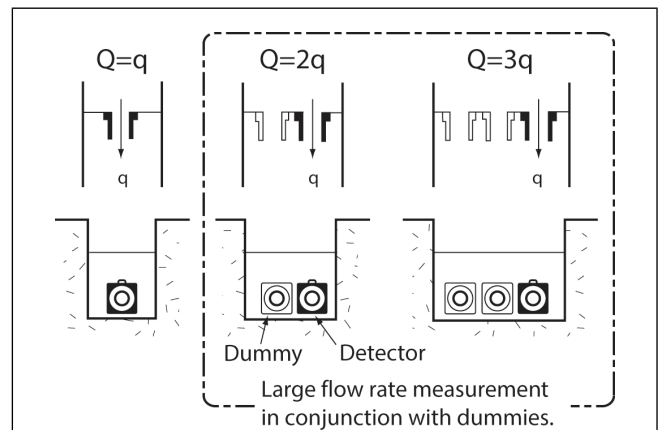
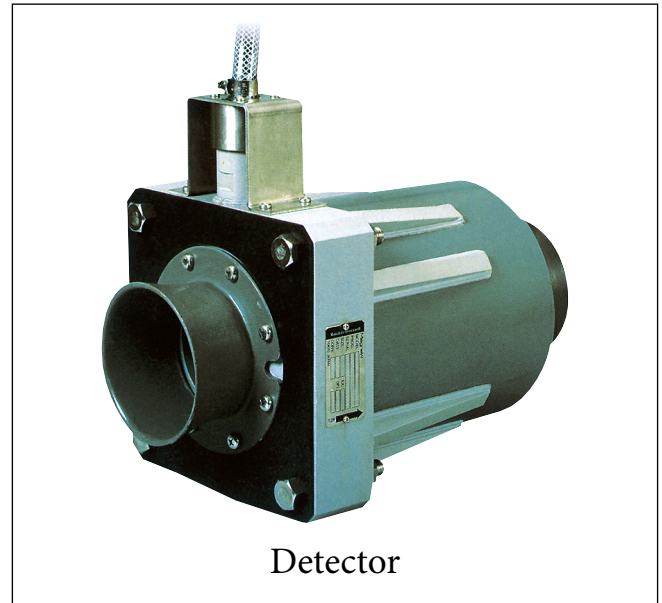

Figure 1. Application

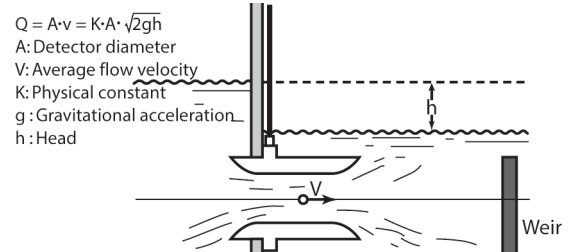

Figure 2. Principle of flow measurement with MagneW Flowmeter

Note) Double flow measurement is available by installing a detector with one dummy of the same size as the detector

## SPECIFICATIONS

### Overall specification

#### Flow velocity range

0-0.3 to 0-10 m/s (Continuously adjustable)

\* Recommended upstream velocity condition: 1 to 4 m/s

#### Accuracy (Combined with the MGG14C)

	Within the recommended condition*	Out of the recommended condition
When detector is used without dummy or dummies	± 1.0% F.S.	± 2.0% F.S.
When detector is used with dummy or dummies	± 2.0% F.S.	± 4.0% F.S.

\* Recommended condition of use.

Without dummy: Straight pipe section on the upstream side of detector is 3 times or over the nominal flowmeter diameter.

With dummy: Straight channel section on the upstream side of detector is twice or more the water channel width

#### Power supply (combined with MGG14C)

90 to 250V AC, 47 to 63 Hz

110A DC ± 10%

24V DC ± 10%

#### Power consumption

Approx. 11 W (Including detector and converter)

### Detector

#### Material of body

Rigid vinyl chloride

(Parts in contact with fluid: SUS304) [Resisting (internal, external) pressure = 0.5 kgf/cm<sup>2</sup>]

#### Materials of electrodes

SUS316L, Titanium

#### Structure

Open channel type

(equivalent to IP68 Underwater Type)

#### Cables (10m for each cable)

One 4-core shielded cable (outer diameter 11.4 mm; length 10 m) with cable protection vinyl tube (outer diameter 22 mm; length 10 m)

#### Electrical conductivity of the measured fluid

5 μS/cm or over

#### Ambient temperature limits

0 to 40 °C

### Weight

50 mm (detector; 10 kg, dummy; 1.4 kg)

100 mm (detector; 23 kg, dummy; 4 kg)

200 mm (detector; 45 kg, dummy; 12 kg)

400 mm (detector; 130 kg, dummy; 41 kg)

600 mm (detector; 220 kg, dummy; 72 kg)

### Average flow velocity of detector (m/s)

Table 1. Flow velocity conversion table

Size (mm)	Flow velocity conversion coefficient K
50	0.1415
100	0.03537
200	0.008842
400	0.002210
600	0.0009824

$$V = K \times Q$$

[V: Flow velocity (m/s), Q: Flow rate (m<sup>3</sup>/h),

K: Flow velocity conversion coefficient  $\frac{1}{3600} \times \frac{4}{\pi D^2}$ ]

[Example] Detector size: 200 [mm],

Flow rate per detector: 250 [m<sup>3</sup>/h]

$$V = K \times Q = 0.008842 \times 250 = 2.21 \text{ [m/s]}$$

### Water level calculation (bell mouth type)

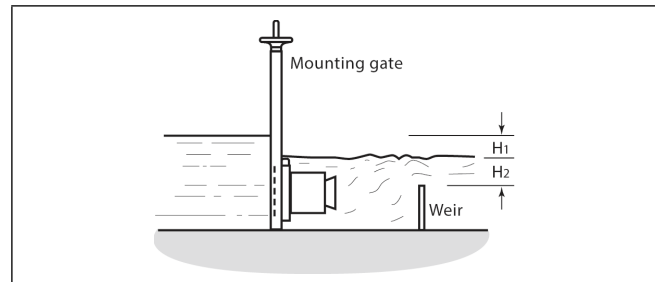

(Example)

Size and number of detector: 200 mm, 1 unit

Size and number of dummy detector: 200 mm, 1 unit

Weir width W: 2 m

Maximum flow rate Qt: 500 m<sup>3</sup>/h

Average flow velocity per detector V: 2.21 m/s

#### Conversion of water head differential (H<sub>1</sub>) to water level

$$H_1 = K_1 \times V^2$$

in which

K<sub>1</sub>: Water head differential conversion coefficient 0.053

(Example)

When the average flow velocity of a detector is 2.21 [m/s]

$$H_1 = K_1 \times V^2 = 0.053 \times (2.21)^2 = 0.259 \text{ [m]}$$

#### Conversion of overflow water depth (H<sub>2</sub>) to water level

$$H_2 = \left( \frac{Q_t}{1.84 \times W \times 3600} \right)^{\frac{2}{3}}$$

(Example)

When the maximum flow rate is 500 [m<sup>3</sup>/h] and sheathing board width is 2 [m]

$$H_2 = \left( \frac{Q_t}{1.84 \times W \times 3600} \right)^{\frac{2}{3}} = \left( \frac{500}{1.84 \times 2 \times 3600} \right)^{\frac{2}{3}} = 0.113 \text{ m}$$

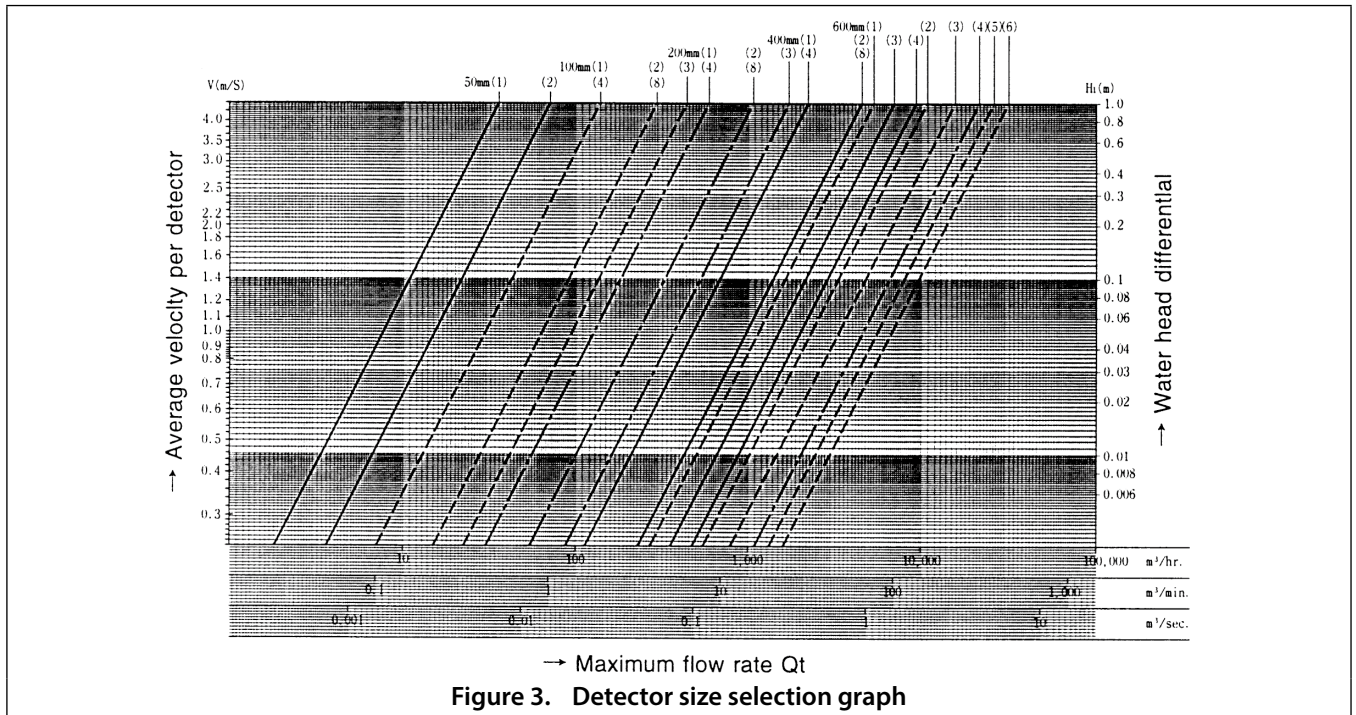

Figure 3. Detector size selection graph

Note) The expression “200 mm (3) means the structure consisting of one 200 mm detector and two 200 mm dummies. (“200 mm” indicates the detector size or aperture and “(3)” means that the total number of detectors including dummy detectors.)

[How to use the graph]

The flow rate is graduated along the lower horizontal axis. If you draw a line upward from the set point of the flow rate and read the point at which the line intersects with the line drawn in a diagonal direction, you can obtain the water head differential at the flow rate. If you read the vertical axis on the left side, you can obtain the flow velocity per detector at the flow rate.

[Example]

Water head differential and flow velocity all flow rate of 500 m<sup>3</sup>/hr

Draw a line upward from the point of 500 m<sup>3</sup>/hr, and it will intersect with the following diagonal lines:

400 mm (4), 400 mm (3), 600 mm (1), 400 mm (2) {= 200 mm (8)}, 400 (1) {= 200 mm (4)}, 200 mm (3), 200 mm (2) {= 100 (8)}, 200 mm (1) {= 100 mm (4)}

When it intersects with 200 mm (2), the water head differential H<sub>1</sub> is about 0.26 m and the flow velocity per detector V (m/s) is about 2.2 m/s.

Water level calculation (elbow flange type)

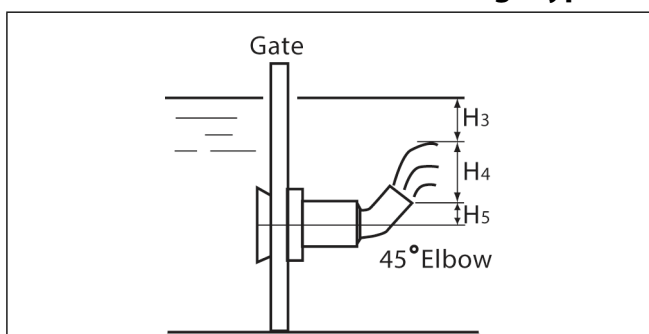

(Example)

Size and number of detector:	200 mm, 1 unit
Size and number of dummy detector:	200 mm, 1 unit
Maximum flow rate Qt:	500 m <sup>3</sup> /h
Average flow velocity per detector V:	2.21 m/s

Table 2. Dimension of H<sub>5</sub>

Diameter	50 mm	100 mm	200 mm
Design dimension H <sub>5</sub>	62 (51 to 72)	105 (94 to 115)	209 (198 to 219)

Conversion of water head differential (H<sub>3</sub>) to water level

$$H_3 = K_3 \times V^2$$

in which

K<sub>3</sub>: Water head differential conversion coefficient for elbow flange 0.072

(Example)

When the average flow velocity of a detector is 2.21 [m/s]  
 $H_3 = K_3 \times V^2 = 0.072 \times (2.21)^2 = 0.352$  [m]

Elbow blow-up height (H<sub>4</sub>)

$$H_4 = K_4 \times V^2$$

in which

K<sub>4</sub>: Elbow blow-up height conversion coefficient 0.028

(Example)

When the average flow velocity of a detector is 2.21 [m/s]  
 $H_4 = K_4 \times V^2 = 0.028 \times (2.21)^2 = 0.137$  [m]

Therefore, the water head from the center of detector  
 $H_3 + H_4 + H_5 = 0.696$  [m]

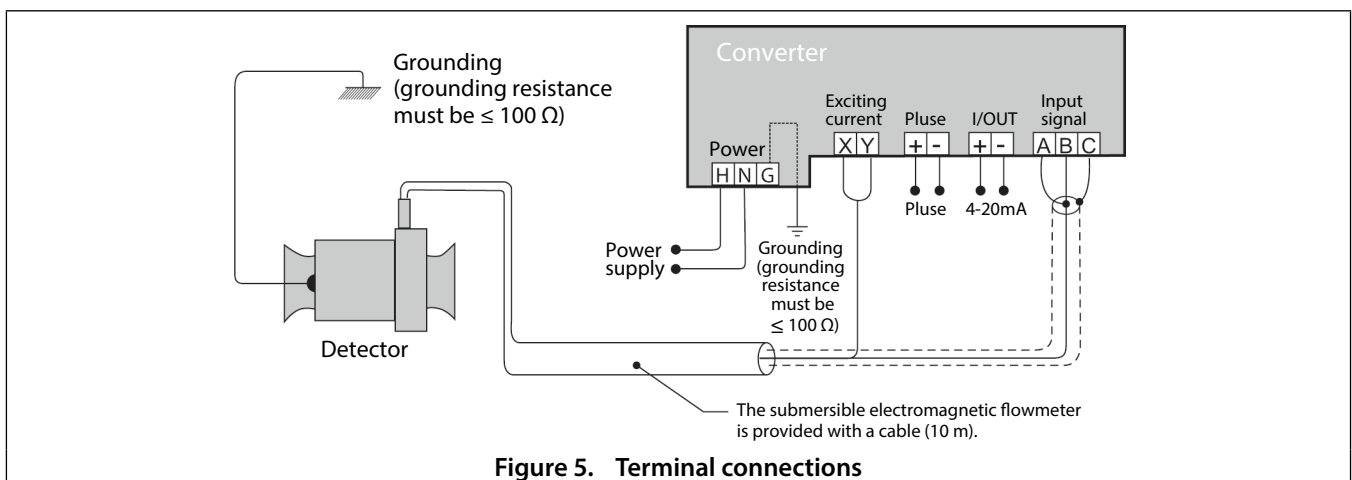
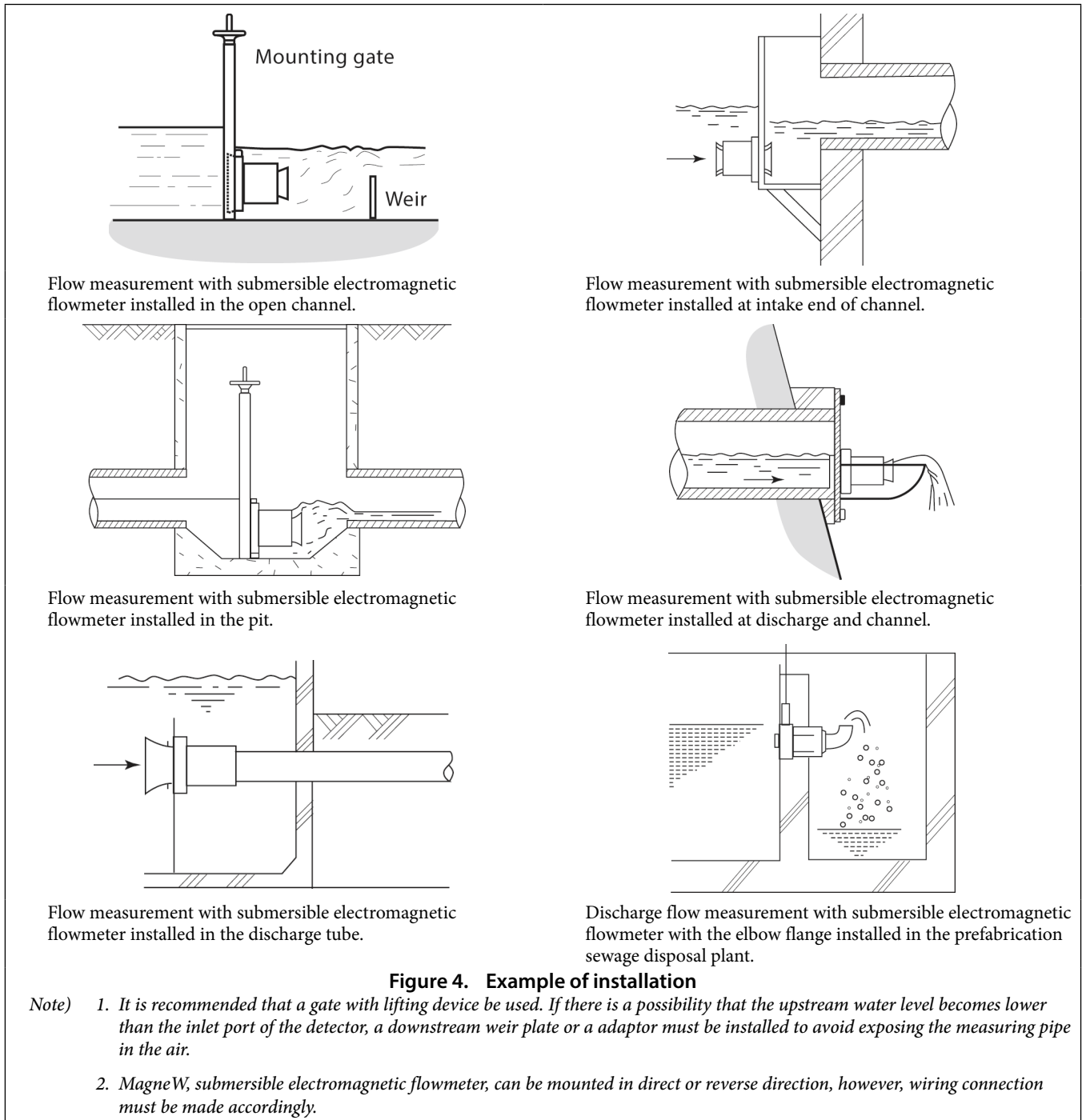

**MODEL SELECTION**

NNK\_\_\_ - I II III IV - V VI

Basic model no.		Basic model no.		Selections			Option	
Basic model no.								
Type	Detector	NNK 150						
	Dummy	NNK 951						
Selections								
I	Nominal size	50 mm		0050				
		100 mm		0100				
		200 mm		0200				
		400 mm		0400				
		600 mm		0600				
II	Electrode material	Without electrode (for NNK 941)			A			
		Titanium (See note 1)			K			
		Stainless steel (SUS 316L)			L			
III	Flange rating	Special flange for MagneW use only			80			
IV	Grounding material	Without grounding ring					A	
Options								
V	None						X	
	With elbow flange (without cover) (See note 2)						A	
	With elbow flange (with cover) (See note 2)						B	
VI	For potable						1	
	For sewage						2	
	Gross drainage regulation and others						3	

- Note) 1. Even when titanium is specified by customer for electrode material, all other metallic parts than the electrodes must be SUS304.  
 2. Not applicable to nominal diameters in 400 mm and 600 mm.

**DIMENSIONS**

**Bell mouth type**

[Unit : mm]

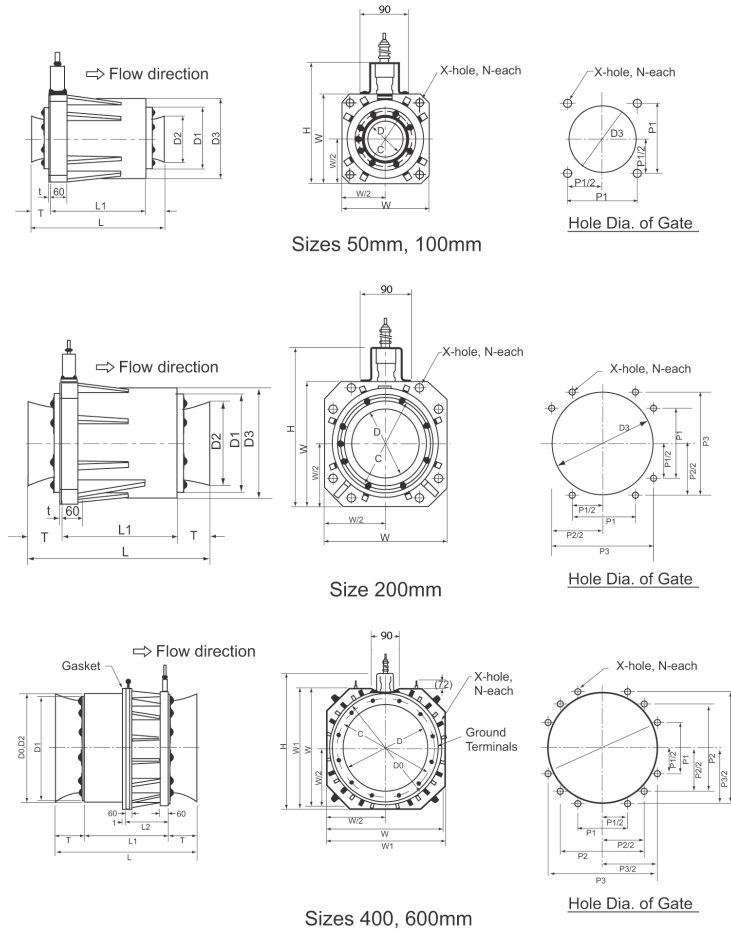
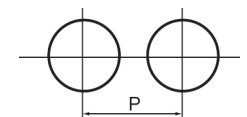

**Figure 6. Detector (bell mouth type)**

**Table 3. External dimensions (Detector)**

[Unit : mm]

Size	Nominal		50	100	200	400	600
	Inside diameter	D	51	100	202	395	592
Depth		L	280	420	560	790	1010
		L <sub>1</sub>	220	280	360	490	610
		L <sub>2</sub>	-	-	-	260	320
Gasket thickness		t	3	3	3	5	5
Bell mouth	Length	T	30	70	100	150	200
	Pitch circle	C	90	150	274	455	658
	Diameter	D <sub>1</sub>	110	170	290	490	690
D <sub>2</sub>		80	130	260	518	728	
Outside diameter		D <sub>0</sub>	140	216	318	520	730
Height		H	249	329	449	687	872
Width		W	160	240	360	640	800
		W <sub>1</sub>	-	-	-	650	810
Minimum parallel installation distance on gate distance on gate (from center to center)		p	165 or more	245 or more	365 or more	670 or more	840 or more
Bolt pitch		P <sub>1</sub>	128	192	210	230	340
		P <sub>2</sub>	-	-	316	424	570
		P <sub>3</sub>	-	-	-	554	730
Bolt	Diameter		12	16	16	24	24
	Length		90	90	90	120	120
Bolt mouth mounting screw	Diameter		8	8	8	8	8
	Length		16	16	16	20	20
Hole diameter of gate		D <sub>3</sub>	120	180	300	550	760
Flange	Hole diameter	X	14	19	19	27	27
	Number of hole	N	4	4	8	12	12



Installation distance on gate

## Elbow flange type

[Unit : mm]

## Detector

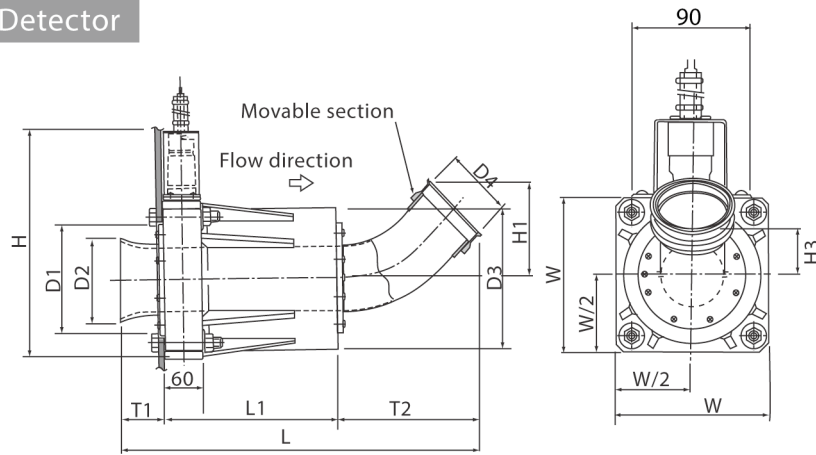

## Dummy

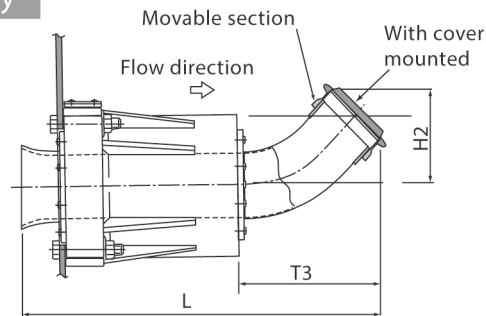

Figure 7. Detector (elbow flange type)

Table 4. External dimensions (elbow flange type)

[Unit: mm]

Size		50 mm	100 mm	200 mm
Face to face	L	367 to 388	569 to 590	876 to 897
	L <sub>1</sub>	220	280	360
Bell mouth	Diameter	D <sub>1</sub>	110	170
		D <sub>2</sub>	80	131
	Length	T <sub>1</sub>	35	77
Elbow	Height (adjustable)	H <sub>1</sub>	73 to 94	136 to 157
		H <sub>2</sub>	-	-
		H <sub>3</sub>	33 to 54	58 to 79
	Diameter	D <sub>4</sub>	50	101
		D <sub>5</sub>	-	-
	Length	T <sub>2</sub>	112 to 133	212 to 233
T <sub>3</sub>		-	-	
Outer diameter	D <sub>3</sub>	140	216	
Height	H	249	329	
Width	W	160	240	
Flange	Hole diameter	X	14	
	Number of hole	N	4	
Weight (without cover) [kg]		11	25	

Dummy - Bell mouth type

[Unit : mm]

Size 50 mm

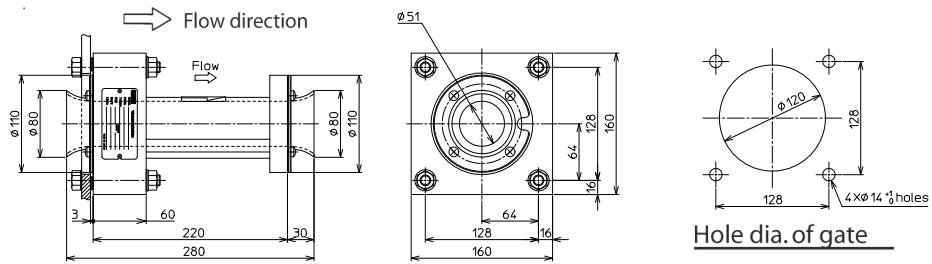

Size 100 mm

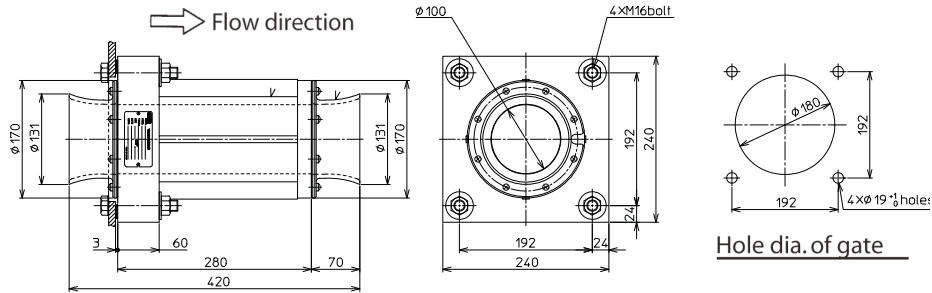

Size 200 mm

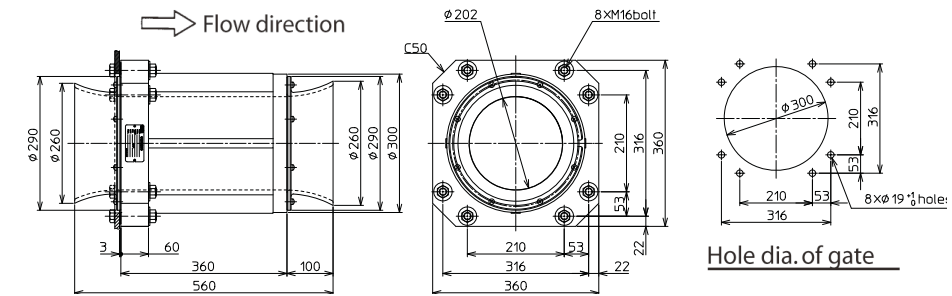

Size 400 mm

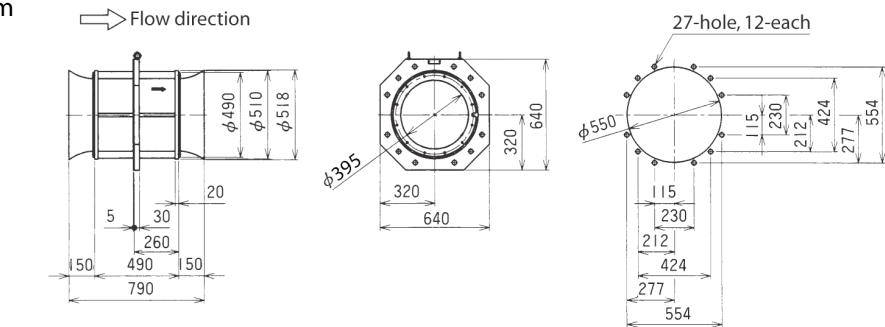

Size 600 mm

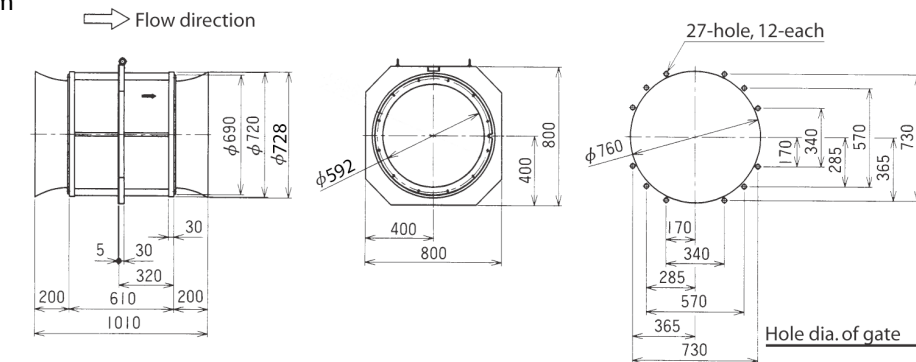

Figure 8. External dimensions (Dummy)



**Dummy - Elbow flange type**

Size 50 mm, 100 mm, 200 mm (Elbow flange type)

[Unit : mm]

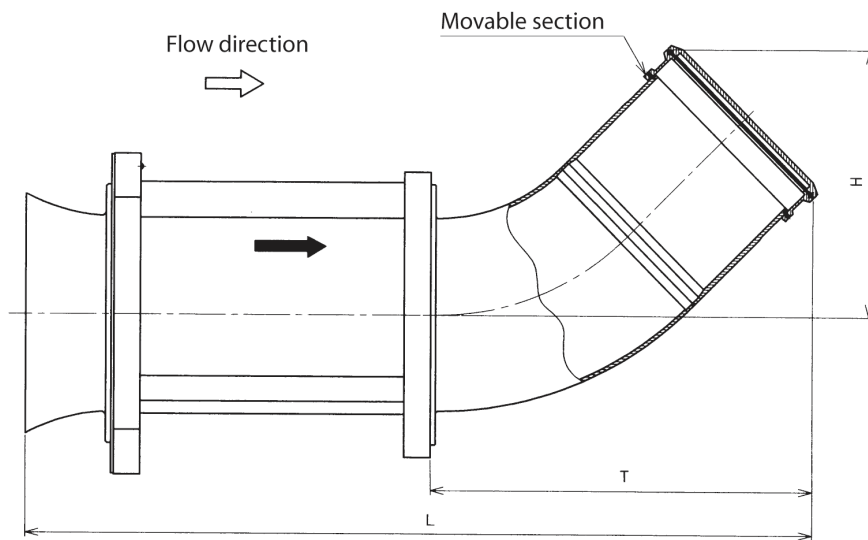

Size	50 mm	100 mm	200 mm
L	364 to 381	566 to 582	876 to 899
H	74 to 90	131 to 148	276 to 300
T	109 to 126	209 to 226	407 to 431

**Figure 9. External dimensions (Elbow flange)**

## Installation Notes

The model NNK flowmeter installation requires attention on the following details.

When designing the open channel, the mounting gate and the weir, it is required to design after good understanding of the flowmeter characteristics.

### ■ Measuring method and water head

The radical principle of this flow meter is an electromagnetic flow meter, and it is installed to the mounting gate board and submerged into the open channel to measure the flow rate.

Flow rate formula (It is well-known as Bernoulli's theorem) is as shown in

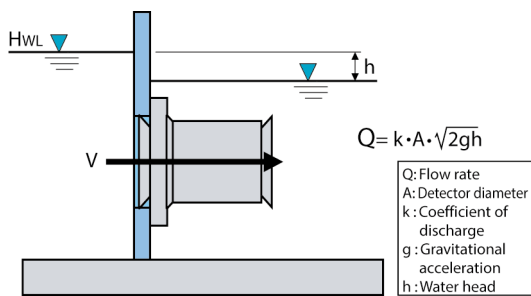

Figure 10. Measurement principle drawing

Moreover, when a large flow rate is measured, it is required to install a few dummy detectors having the same structure and the coefficient of discharge on the mounting gate board. Use the detector together with the dummy detectors while measuring the flowrate. In principle the flow rate of dummy detectors are of the same flow-rate with that of the detector. The converter which is in combination with detector will output a signal with integral multiples of the flow-rate based on the configured number of dummy detectors in the converter.

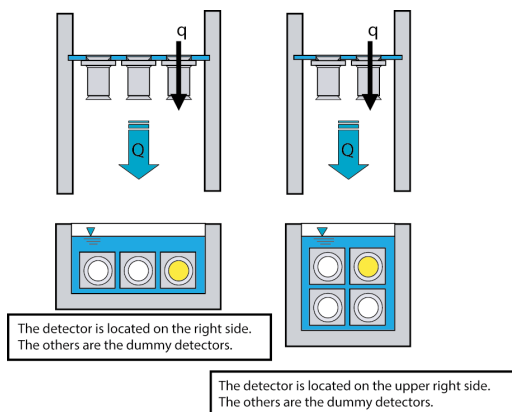

Figure 11. Installation for dummy detector

### ■ Water-submerged condition

This flowmeter must always be used in submerged condition where the water fully fills the inside of the detector.

#### [Bell mouth method]

As for the bell mouth method, provide a weir on the downstream side, and its design should ensure submerged condition where the water fully fills the inside of the flowmeter with the open channel, the mounting gate and the weir.

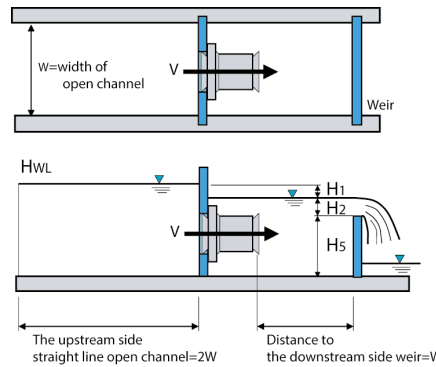

Figure 12. Water head design (Bell mouth type)

#### [Elbow flange method]

The Elbow flange method is a structure which ensures that the inside of the flow meter is fully filled with water without using the weir.

Please note that the elbow flange must be installed only as an blow-up elbow open to the atmosphere. (Do not install as an blow-down elbow.)

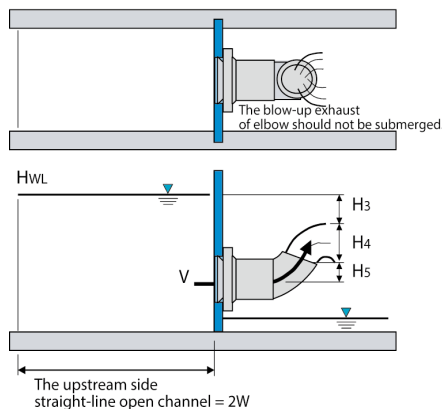

Figure 13. Water head design (Elbow flange method)

### ■ Arrangement of detector and dummy

#### [Bell mouth method]

For large flow measurements using the bell mouth method, the number of dummy detectors can be increased in the vertical and the horizontal directions. When one or more dummy detectors are to be installed in the vertical and the horizontal directions, install at a location where it seems that the average flow velocity is generated and it avoids the wall side of the channel.

The water head difference when a dummy detector is added in the vertical direction is different. It appears that flow velocity at the upper and lower position are different. It is confirmed that even the detector installed in the vertical direction will be able to get the flow rate within the rated accuracy due to the effect of the weir which is installed on the down stream side.

#### [Elbow flange method]

In case of the elbow flange method, the dummy detectors can be added only in the horizontal direction. Addition of the dummy detector in the vertical direction is not possible, as this method is different from the bell mouth method. In this method a weir is not installed and thus it is not possible to equalize the velocity of the water.

### ■ Structure of open channel (recommended condition)

The following conditions are recommendable for the design of the open channel (refer to Figure 12, 13)

When these lengths for the open channel cannot be kept, it is necessary to provide a flow stabilizing plate to avoid generating wind drift etc.

- Distance of the upstream side straight line open channel.
  - Use detector alone = Twice of detector diameter
  - Use detector with dummy = twice of open channel width  $W$
- Distance to the downstream side gate board = open channel width  $W$

*Note* In case of the bell mouth type, a weir should be provided in the downstream side.

### ■ Structure of gate board (recommended condition)

The gate board on which the elbow flange-type detector and dummy detectors are installed must bear the weight of the detectors and of the water that flows through them. Therefore, use a board that is strong enough and that will not warp. If the gate board warps, leakage will occur between the board and the detectors, and measurement will be incorrect.

The following conditions are recommendable for the design of the mounting gate board and flowmeter (detector and dummy).

It is required to secure the following distance.

- Distance from open channel wall = 150 mm
- Distance from bottom = 100 mm
- Detector pitch  $\Rightarrow$  Refer to Figure 6 pitch between gate.

The above data are to be followed for maintenance clearance and mounting the detector on to the gate board.

Moreover, when using the Elbow flange method the accuracy is influenced when there is a water height difference, when the water outputs from the blow-up elbow into the atmosphere.

Especially, when one or more dummy detectors are used, ensure to equalize and maintain the elbow blow-up water height ( $H_4$ ) difference by adjusting and aligning the direction of the blow out elbow movable section of the dummy detectors and the main detector.

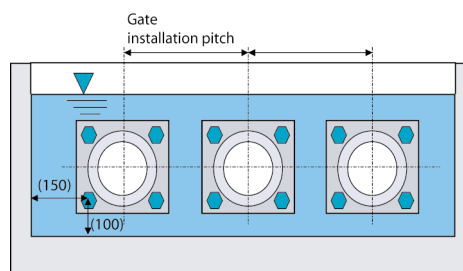

Figure 14. Installation pitch

### Calculation example - A

Measure discharge water of flow rate 100 ( $\text{m}^3/\text{h}$ ) with the Bell mouth type detector in the open channel of width of the mounting gate (1 m).

#### 1. Decide the length and width of the open channel

Measurement in an open channel using the dummy detector in the bell mouth type for a width  $W$ , the calculation for the required length is,  $L = (2W$  on the upstream + detector  $F$  to  $F$  dimension +  $1W$  on the down stream) therefore,  $L = 3W +$  Detector  $F$  to  $F$  dimension. The required depth of the open channel must be equivalent to height of the detector. The width of the open channel is to be designed considering the number of dummy detectors to be installed.

Please refer Figure 6, to review an example for a detector with diameter 100 mm and whose detector casing width is 240 mm.

The recommended gate installation pitch between detectors should be 245 mm or more.

Moreover, when you secure both sides the maintenance space of 150 mm or more, refer Figure 14, then,

$$1000 - 150 \times 2 = 700$$

$$700 \div 245 > 2$$

The installation of two or less (detector and dummy) becomes possible.

#### 2. Calculate flow velocity.

The flow velocity conversion table mentioned on page 2 is used and calculated.

$$V = k \times Q = k \times q \times n$$

As mentioned in the table, for a detector diameter of 100 mm, the corresponding flow velocity conversion coefficient  $k$  is 0.03537

Measurable 2 nos. (1 no. detector + 1 no. dummy)  
Flow rate for each detector is  $50 \text{ m}^3/\text{h}$

$$V = 0.03537 \times 50 = 1.7685 \text{ (m/s)}$$

#### 3. Calculate the required water head difference.

Water level calculation formula of water head difference of page 2 is used.

$k_1$  uses 0.053 by the constant.

$$H_1 = k_1 \times V^2$$

$$= 0.053 \times (1.7685)^2$$

$$= 0.166 \text{ (m)}$$

Moreover, overflow depth  $H_2$  of the weir is calculated.

$Q$ : flow rate, 1.84: constant, and  $W$  substitutes the width of the open channel.

$$H_2 = \left( \frac{Qt}{1.84 \times W \times 3600} \right)^{2/3}$$

$$= \left( \frac{100}{1.84 \times 1 \times 3600} \right)^{2/3}$$

$$= 0.061 \text{ (m)}$$

**4. Calculate the height of the mounting gate and the weir.**

According to Figure 6, the height from the bottom of diameter 100 mm to center  $w/2 = 120$  mm. Let's assume flow rate = 0 (m/s) with an water-submerged condition, the water level control by height of weir to the bell mouth height is giving below.

$$\begin{aligned} \text{Height of weir} &= \text{maintenance height} + (w/2) + (D/2) \\ &= 100 + 120 + 65 \\ &= 285 \text{ (mm)} \end{aligned}$$

$$\begin{aligned} \text{Height of water level} &= \text{height of weir} + H_1 + H_2 \\ &= 285 + 166 + 61 \\ &= 512 \text{ (mm)} \end{aligned}$$

Therefore, recommendable weir is 285 mm, the required mounting gate height should be 512 mm or more.

**Calculation example-B**

Measure the discharge water of flow rate 600 (m<sup>3</sup>/h) with elbow flange type detector and the width of the mounting gate (1.8 m).

**1. Confirm the limitation on the length and width of the open channel in which the detector is installed.**

In case of the elbow flange type, the length against to width W of open channel is [upstream 2W + detector F to F dimension] therefore, it is required [2W + detector F to F dimension]. Similar to the Calculation example-A, calculate the width of the open channel.

Please refer Figure 7, to review an example for a detector with diameter 200 mm and whose detector caring width is 360 mm. The recommended gate installation pitch between the detectors should be 365 mm (5 mm clearance is added).

When you secure the maintenance space of 150 mm or more for both sides with the open channel, then

$$\begin{aligned} 1800 - 150 \times 2 &= 1500 \\ 1500 \div 365 &> 4 \end{aligned}$$

Therefore, the installation of four (detector and dummy) or less becomes possible.

**2. Calculate flow velocity.**

The flow velocity conversion table of page 2 is used and calculated.

$$V = k \times Q = k \times q \times n$$

As mentioned in the table, for a detector diameter of 200 mm, the corresponding flow velocity conversion coefficient  $k$  is 0.008842, and measures it with four (detector and dummy), therefore,

flow rate for detector is 150 (m<sup>3</sup>/h).

$$V = 0.008842 \times 150 = 1.3263 \text{ (m/s)}$$

**3. Calculate the required water head difference.**

Water level calculation formula of water head difference of page 3 is used.

$k_3$  uses 0.072 by the constant.

$$\begin{aligned} H_3 &= k_3 \times V^2 \\ &= 0.072 \times (1.3263)^2 \\ &= 0.127 \text{ (m)} \end{aligned}$$

Moreover, calculate height  $H_4$  of Elbow of blowing up.

$k_4$  uses 0.028 by the constant.

$$\begin{aligned} H_4 &= k_4 \times V^2 \\ &= 0.028 \times (1.3263)^2 \\ &= 0.049 \text{ (m)} \end{aligned}$$

**4. Calculate the height of the mounting gate and the weir.**

For detector with diameter 200 mm, the height from the detector center to the blow out center ( $H_5$ ) is 207 mm.

Therefore, the water head difference from detector is

$$H_3 + H_4 + H_5 = 383 \text{ (mm)}$$

For a detector with diameter of 200 mm, the height from the bottom to its center is 180 mm.

To consider the maintenance height, add 100 mm.

$$\begin{aligned} \text{Height of water level} &= \text{maintenance height} + (W/2) + 383 \\ &= 100 + 180 + 383 \\ &= 663 \text{ (mm)} \end{aligned}$$

Therefore, it requires the mounting gate with 663 mm or more.

MagneW is a trademark of Azbil Corporation in Japan and/or other countries.

Please read "Terms and Conditions" from the following URL before ordering and use.

<https://www.azbil.com/products/factory/order.html>

Specifications are subject to change without notice.



**Azbil Corporation**  
Advanced Automation Company

1-12-2 Kawana, Fujisawa  
Kanagawa 251-8522 Japan  
URL: <https://www.azbil.com/>

1st edition: Sep. 2008  
6th edition: Apr. 2023

No part of this publication may be reproduced or duplicated without the prior written permission of Azbil Corporation.