

Admass Coriolis Mass Flowmeter Model RC111C Converter RC111F/111U Detector

User's Manual

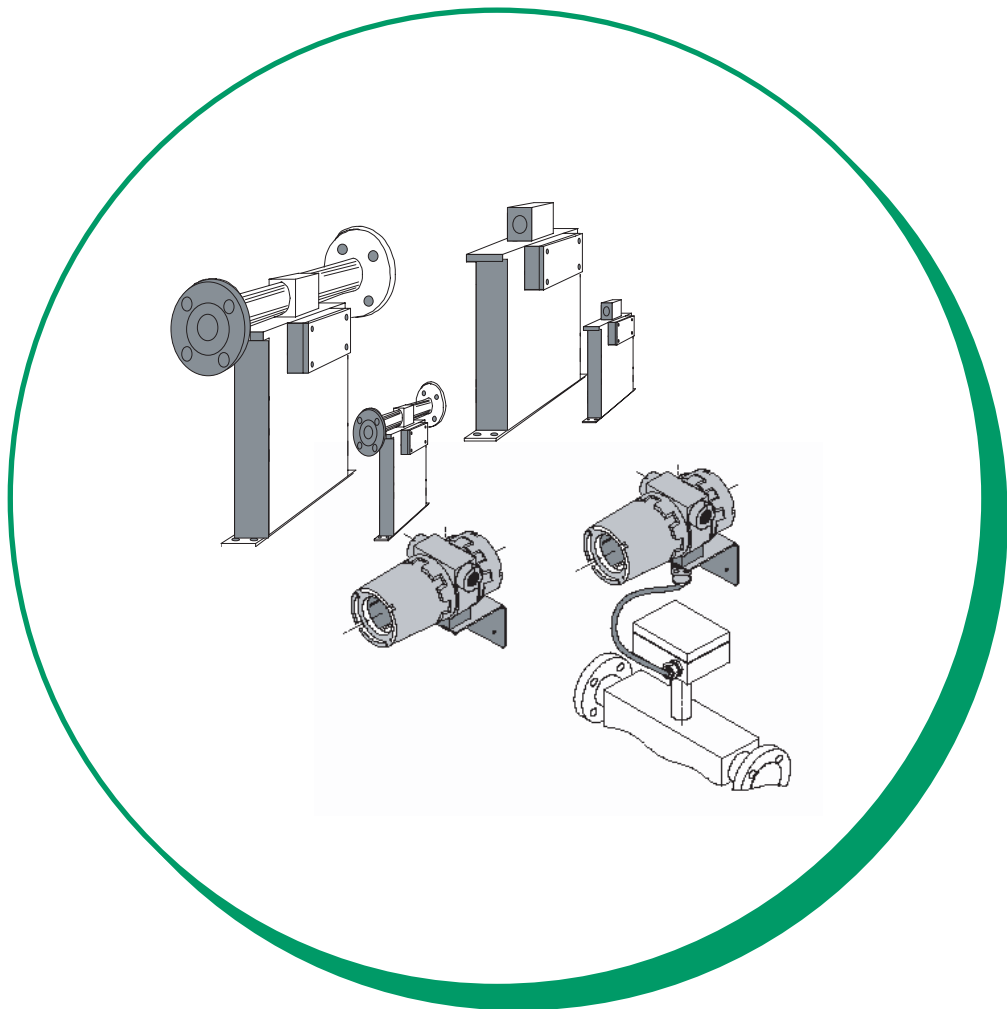

Azbil Corporation

NOTICE

While the information in this manual is presented in good faith and believed to be accurate, Azbil Corporation disclaims any implied warranty of merchantability or fitness for a particular purpose and makes no express warranty except as may be stated in its written agreement with and for its customer.

In no event shall Azbil Corporation be liable to anyone for any indirect, special or consequential damages. This information and specifications in this document are subject to change without notice.

Important safety instructions for operating mass flowmeters

Please ensure that the following safety guidelines are observed at all times

WARNING

When installing the appliances in hazardous areas, please observe the relevant local installation regulations.

The flowmeters are made for a variety of applications and in compliance with international standards. The operating conditions for the appliance are stated on the serial number plate and must be observed at all times.

Where heated measuring sensors are concerned, sufficient thermal insulation should be provided to ensure that the entire measuring sensor is always kept at the operating temperature.

Please ensure that no rapid changes in the measuring instrument temperature are caused by the measuring medium and observe the instructions given in this manual.

If the appliance is to be installed outdoors, and most notably in warmer climates, weatherproof protection will need to be installed for the transmitter in order to protect it against the impact of direct sunlight.

The maximum permissible pipeline pressure for the measuring sensor can be found on the serial number plate. When using piston pumps, always remember that no pressure peaks should be allowed to emerge which are above the maximum permissible pressure level. Prior to delivery, the measuring tubes are subjected to an overpressure test which is performed at 1.5 times the permissible operating pressure.

We wish to point out that the abrasive medium may reduce the wall thickness of the measuring tubes and consequently lower the maximum operating pressure.

The construction material that comes into contact with the medium can be found on the serial number plate. The manufacturer assumes no responsibility for the corrosion resistance of the measuring instrument with regard to the medium to be measured.

 **CAUTION**

Should the stability of the material that has been moistened by the medium be in doubt, we recommend that you check the wall thickness of the measuring tubes from time to time.

Azbil Corporation assumes no liability for the loss of production and/or consequential damage unless this has been expressly agreed upon.

Measuring sensors for liquid foodstuffs and luxury foods or for pharmaceutical usage must be completely scavenged before being used.

By way of avoiding electrostatic charge, the window on the transmitter may only be cleaned using a moist, antistatic cloth.

When used in hazardous areas, never open the transmitter casing while the power supply is connected.

Only certified, type “Ex-d” cable bushings should be used in hazardous areas.

All unused cable bushings located in hazardous areas must be sealed using certified, type “Ex-d” plugs.

To ensure that the appliances meet the demands of protection class IP66 (as prescribed by EN 60529) following installation, please consider and observe the following points:

All of the casing screws must be tightened.

Always use suitable cable glands for the outer diameter of any cables that may be used.

Tighten the cable glands.

Unused cable glands must be replaced by plugs.

Close all of the casing covers tight so that the sealing washers between the casing and the cover are under pressure and sealed.

The limit values for the maximum permissible medium and ambient temperatures must be observed at all times. The permissible temperature for the measuring sensor can be found on the serial number plate. The permissible temperature for the transmitter is 55°C

Manufacturer's Liability:

CAUTION

Given the warranties and liabilities accepted by the manufacturer, please note that the measuring instruments may not be utilised in life-preserving systems used in medical applications, or in motor vehicles, aircraft, watercraft or in the mining industry. In addition, the manufacturer accepts no liability for damage resulting from the improper or non-compliant usage of the appliance.

Liability for consequential damage or loss of production will solely be accepted if the customer expressly requires such liability or if it has been expressly agreed in the sales contract.

Typical Applications and Benefits

Admass coriolis mass flowmeters have been used by industry to determine the volume of such liquids and gases as:

- Acid, lye, alcohol, hydrocarbons
- Bitumen, fats
- Oils (mineral oil, vegetable oil, synthetic oil)
- Foodstuffs (vegetable oil, beer, liquid yeast, liquid sugar, chocolate, soup, sauces)
- Beverages, flavouring, liquid carbon dioxide
- Lacquers, paint, filling compounds, rubber products
- Fuel (methanol, diesel, petrol, kerosene, methane gas, liquid hydrogen)
- Coolant, hydraulic oil, brake fluid
- Deionized (non-conductive) water
- Animal fodder additives (molasses, rape seed oil, flavouring)
- Pharmaceuticals
- Cosmetics (creams, scented oils, emulsions)
- Polyol, isocyanate, polyester, propellants (freon, pentane, etc.)
- Gas station products (natural gas, propylene, propane)
- Ultra-cold, liquid gases (hydrogen, nitrogen, oxygen, etc.)
- Slurry, suspensions (oil/water)

The advantage of using this patented measuring principle is that it allows for direct mass flow measurement. Given the rapid reaction time, the appliances are suited to both batch dosing and flow control or monitoring. The measurement is taken regardless of the pressure, temperature, viscosity, conductivity or flow characteristics of the liquid. Due to its unique design, the measuring sensor is durable enough not to wear down even after many years of operation and is also a low-maintenance product. Inside the liquid stream, there are no fittings or rotating parts that could block the flow and consequently lead to a very costly shutdown of the production facilities. Installing the flowmeter into the pipeline system is easy. No long tube runs in front of and behind the sensor need to be taken into account and the measuring sensor can be mounted

almost directly behind turbulence creating elbows or pipe diameter reducers without impairing the accuracy of the measurements. Measuring media with fibrous content a high solid charge does not pose any real difficulty. If used in accordance with the instructions, it is, unlike positive-displacement counters, possible to do without expensive filters without actually damaging the measuring sensor. Measurements can be taken by the measuring sensor irrespective of the flow of the liquid. Sudden pressure peaks or water shocks in the pipeline will not damage the appliance. In such an instance, other purely mechanical measuring procedures are prone to impeller wheels overtorquing, axles breaking, or bearings becoming displaced, which all result in the measuring device becoming unusable or even blocking the flow of liquid. Azbil Corporation appliances are calibrated at the manufacturer's site on precision test benches and can be operated directly without the need for local adjustments. A calibration certificate is supplied with the appliance.

Installation Quick Guide

This is a short version, please read also our Field Manual

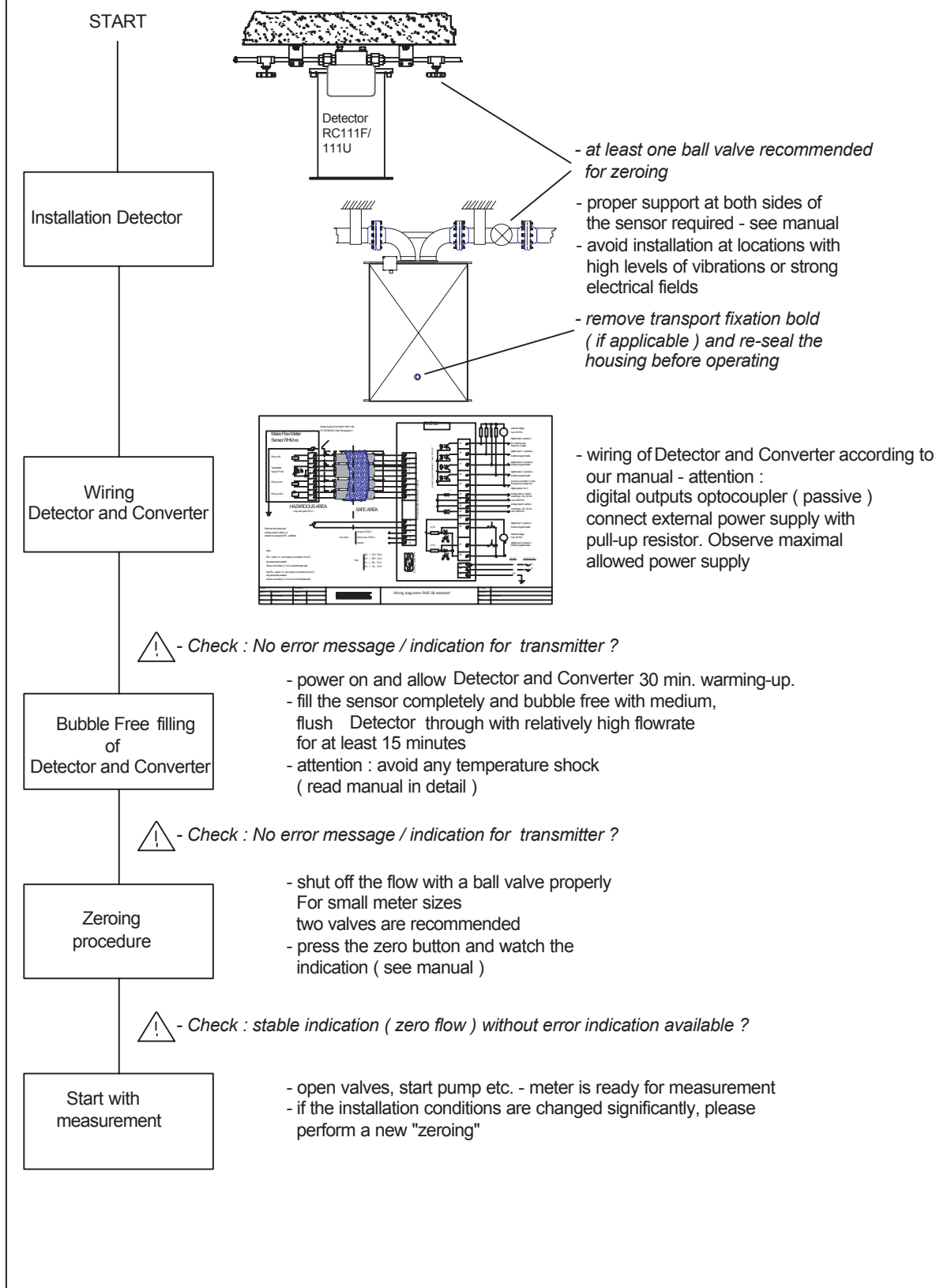

Table of Contents

Chapter 1: General Description of System

1.1 The Flow Measurement System	1-1
1.2 Dimensions of Converter Casing	1-2
1.3 Dimensions of Detector	1-2
1.4 Installing the Converter	1-3

Chapter 2: Assembly and Installation

2.1 Installation Instructions for Measuring Detector	2-1
2.1.1 Heating / Filling a detector:.....	2-5

Chapter 3: Electrical Connection of Converter RC111C

3.1 Cable Specifications	3-1
Type 1: Standard cable. suitable for all appliances	3-1
Type 2: High-temperature cable. suitable for all appliances.....	3-1
3.2 Wiring between the measuring detector and converter	3-1

Chapter 4: Installation of the Converter

4.1 Connecting the Power Supply	4-1
---------------------------------------	-----

Chapter 5: Operation and Programming

5.1 Basic Operation and Settings Principle	5-1
Important Note!	5-2
5.1.1 Start -up Display	5-2
5.1.2 Measurement Display	5-2
5.2 User Set-up	5-3
5.2.1 Resetting the Mass Totalizer	5-3
5.2.2 Zeroing	5-3
5.2.3 Measurement Value Damping	5-3
5.2.4 Rate and Quantity Unit Display	5-4
5.2.5 Low -flow Cut -off	5-4
5.2.6 Allocation of Analog Output Function	5-4
5.2.7 Span Analog Output	5-4
5.3 Basic Settings	5-5
5.3.1 Scaling - M	5-5
5.3.2 Scaling - D	5-5
5.3.3 Device Hi -limit Range	5-5
5.3.4 Temperature Compensation	5-6
5.4 Diagnostics Display Primary Detector Signals	5-6
5.4.1 Diagnostics - Measuring Frequency	5-6
5.4.2 Diagnostics - Analog Output	5-6
5.4.3 Diagnostics - Pulse Output	5-7
5.4.4 Detector Diagnosis	5-7
5.4.5 Display Run -Time Counter	5-7

Chapter 6: ZEROING PROCEDURE

Chapter 7: ERROR DIAGNOSTICS

Table of Contents

Chapter 8: Adjusting the Converter

8.1 Setting the Frequency Divider, Pulse Output and Measuring Frequency.....	8-1
--	-----

Chapter 9: Troubleshooting

9.1 Error status of output	9-1
9.1.1 Pulse Output	9-1
9.1.2 Current Output.....	9-1
9.2 Notes on Troubleshooting	9-1
9.2.1 No Display available on the Device	9-1
9.2.2 Error Display “Pickup Error”	9-2

Chapter 10: Technical Data - Converter

Chapter 11: Technical Data - Measuring Detector

Chapter 12: Display. Matrix

12.1 Specific marking:	12-4
12.2 Additional marking:	12-6

Chapter 1: General Description of System

1.1 The Flow Measurement System

The flowmeter consists of a:

Detector, type RC111F/111U

Converter, type RC111C

Connection cable

Inside the measuring detector, there are precision tubes that are energized by an electromagnetic drive system, which itself is fed by the converter, to vibrate at their natural frequencies.

When a liquid or gas flows through the vibrating tubes, it is subjected to additional deflection due to the degree of inertia that is generated. This deflection is recorded electronically by two velocity sensors and a high-precision electronic time delta.

This measured quantity is proportional to the mass flow rate. A further conversion into physical units is done in a purely digital manner using a signal processor in the transmitter. At the same time, all of the appliance's functions are constantly monitored. Should any disruptions occur, all of the errors that have occurred are immediately reported in the display.

The converter has a 4 to 20 mA analogue output with programmable span, which is proportional either to the measured mass flow rate or the temperature; it also has an impulse output that supplies mass-proportional impulses.

All of the outputs and measuring functions can be verified at any time by the user by using the diagnostic mode in the appliance. The maintenance or new calibration intervals can be monitored via a run-time counter.

For service or repair purposes, the converter and detector can be replaced independently of each other. This significantly reduces the costs of spare parts for the installed flow devices.

During the factory calibration, the detector can be calibrated independently of the converter. All detector-specific calibration data can be programmed using magnetic switches located on the front panel.

To achieve this, the instrument does not need to be opened. All of the relevant data is buffered in a non-volatile semiconductor device (EEPROM).

1.2 Dimensions of Converter Casing

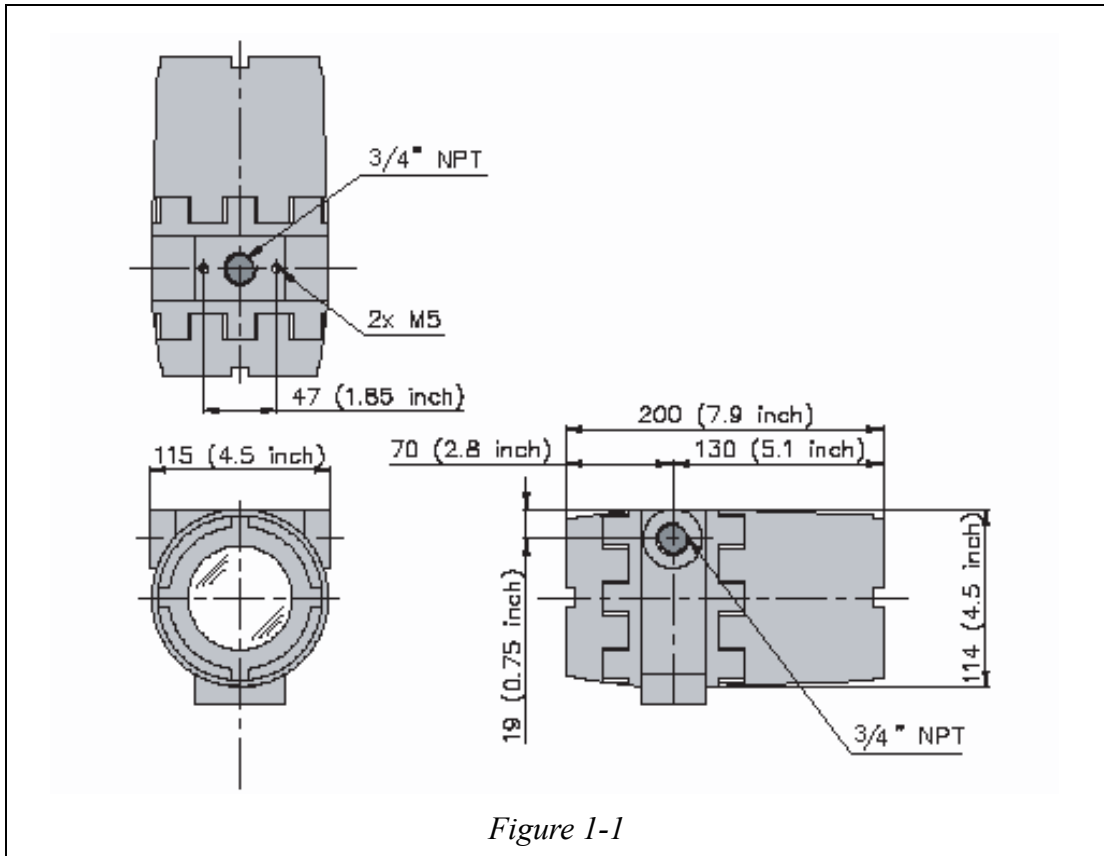

1.3 Dimensions of Detector

The dimensions can be found in individual data sheets, irrespective of the application of the detector. Data sheets or exact drawings for customized products can be obtained from the dealer or the manufacturer.

1.4 Installing the Converter

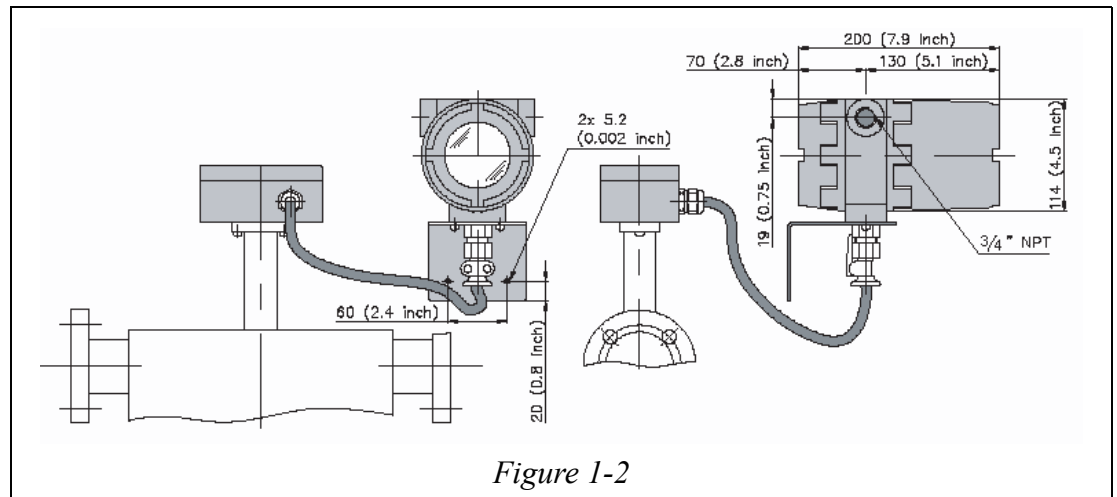

Wiring Instructions:

Never install or wire the appliance while it is connected to the power supply.

Always ensure that you connect the ground wire.

Always observe the permissible voltage stated on the serial number plate of the appliance.

The cable screens should be connected as shown on the connecting diagram.

Special care must be taken to ensure that the cable screens on the measuring detector do not come into contact with the measuring detector casing (earthing connector) unless otherwise prescribed.

The recommended maximum length of cable between the measuring detector and the converter is 10 meters.

Never allow cable bushings located between the measuring detector and the converter in the switch cabinets and the cable ducts to run alongside leads carrying high electric current from electric machinery or inductive switch elements (electromotors, frequency inverters, phase controllers, high-performance contactors, electric heaters, choke coils, etc.). Always maintain a minimum clearance of 1 meter.

Never run the measuring detector cable close to magnetic field sources such as electrical heating coils, transformers or electric motors. The cable screen cannot act against magnetic fields.

Always check the potential equalization between the converter casing and the measuring detector casing.

The cable used at the measuring point must always be temperature resistant. If necessary, use a high-temperature cable between the detector and the terminal box.

Securely screw down the terminal box once it has been installed (to avoid corrosion, moisture-related short circuiting) and ensure that suitable cable glands are used that have been adequately sealed.

Important for trouble-free operation **CAUTION**

Both the converter and the measuring cable must be installed as far away as possible from any sources of electrical interference (transformers, high-voltage switch elements, large electric motors, frequency inverters, etc.).

Chapter 2: Assembly and Installation

2.1 Installation Instructions for Measuring Detector

The direction of flow through the measuring detector is bi-directional. The pipeline next to the measuring detector should be rigidly mounted as closely as possible to the hydraulic connectors using pipe clamps.

Any unsecured sections of the pipeline situated near the measuring detector that might be caused to vibrate should be avoided at all costs.

Due to the construction of the measuring detector and the digital measuring filter of the signal processor, it is possible to minimize the amount of interference caused by vibrations in the system.

Nevertheless, heavy vibrations can result in the measuring accuracy being significantly impaired and, in certain circumstances, in the measuring detector being damaged. The critical frequency range is between 50 and 300 Hz.

It is recommended that you install the measuring detector at a point that vibrates as little as possible.

A good decoupling requires having solid pipe clamps and a place of installation with a rigid surface.

Where liquids with a low vapour pressure are concerned, the system pressure on the entry side of the measuring detector must maintain a certain safe gap above the vapour pressure as otherwise measuring detector cavitation may result which could significantly impair the accuracy of the measurements. Where necessary, a pressure regulator should be installed downstream from the detector. Once the flowmeter has been installed, the measurement system will need to be zeroed. In order to ensure the accuracy of the measurements, this must be performed under full operating conditions with the measuring detector filled. Only non-leaking, high-quality valves can ensure absolute zero flow during the zeroing procedure. In the majority of cases, simply switching off the pump will not be sufficient.

For liquid measurements with solid particles, with a particle diameter of 0.5* inside diameter for the measuring tubes (see pipe dimensions on the serial number plate of the measuring detector), a liquid filter will need to be installed upstream from the measuring detector.

A gas filter must be installed for gas measurements with abrasive particles in the stream

(e.g. rust particles) in order to avoid any damage (abrasion) occurring to the measurement tubes.

For liquid measurements, the detector transmitter should be installed at a low point in the pipe system as this will prevent gas bubbles from forming in the detector.

Avoid heavy shocks or rapid acceleration in the measuring detector. The measuring detector should be installed in such a way that it can be kept at the same temperature for virtually the entire time.

⚠ CAUTION

When using large-sized measuring detectors, always ensure that the shaft block is removed before start-up and the orifices have been sealed tight again.

Example of System:

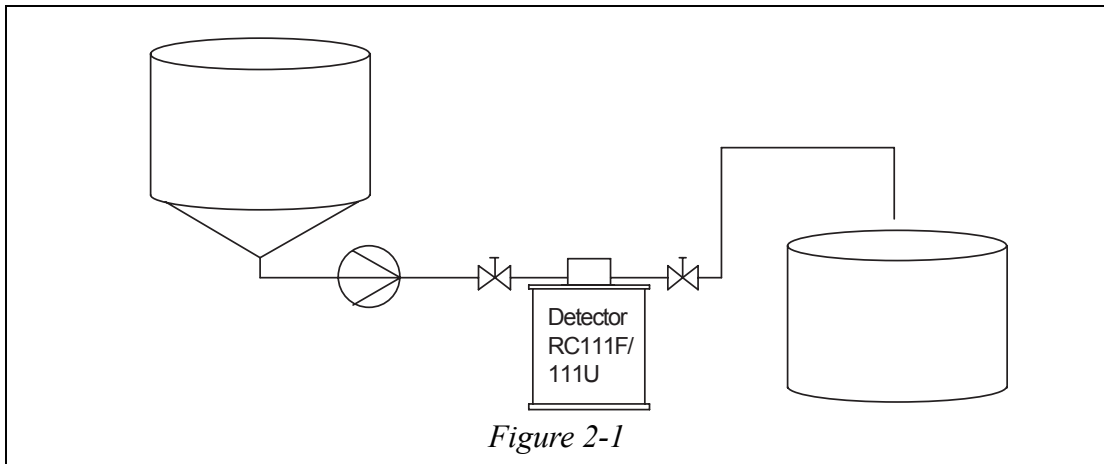

At this point, the pipe system must be as free as possible from all vibrations. In principle, standard buildings or system vibrations have no significant impact on the accuracy of the measurements. Nevertheless, very heavy vibrations should be avoided at all costs.

Please observe the following information on where to install the detector.

Installation Plan

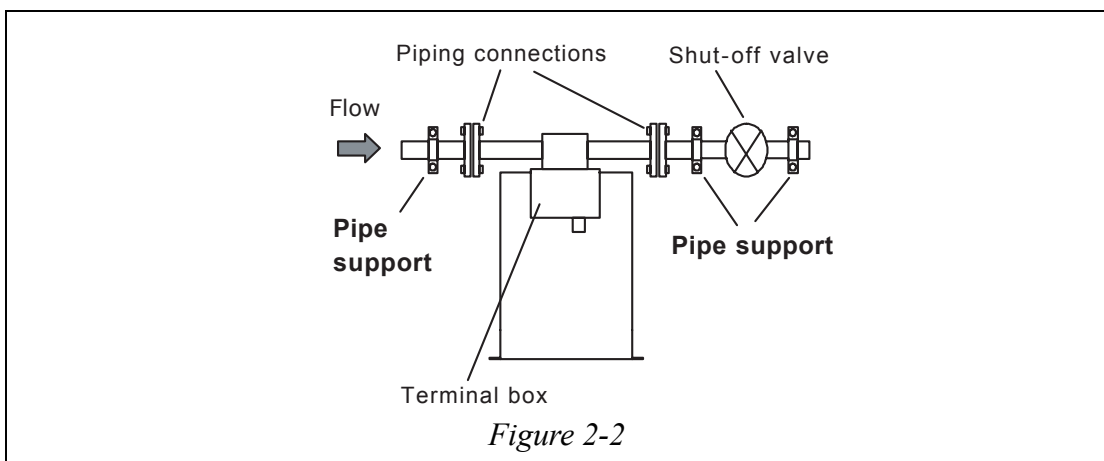

To measure the liquids, a detector should be installed in such a manner that the pipeline connections are located upstream and the casing faces downwards (see drawing); where gases are concerned, the detector should be installed with the pipeline connections pointing downwards (with the casing pointing upwards). The detector should be filled to the top with the medium in question. In doing so, all of the gas bubbles must be removed entirely from the appliance before start-up. This can be achieved, for example, by rinsing the pipes for several minutes at a high flow rate.

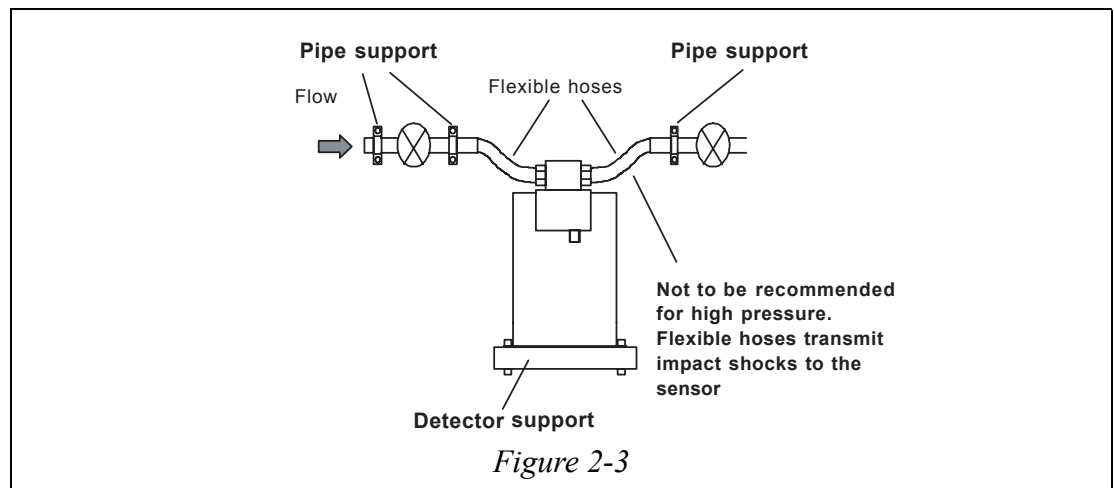

It is also possible to install flexible hoses. However, impact shocks are transmitted to the measuring detector as a result of the setup of the hoses which may interfere with the measurements at high pulsating pressure levels.

This type of installation should be seen as an alternative in the event that it is not possible to mount the unit onto the pipe suspensions.

If flexible hoses are connected directly onto the sensor, the flanges on the casing may be used to affix the detector.

To ensure a stable zero point, the detector must be permanently installed at all costs.

For lower measurement ranges in liquids (5 - 30% of the final range), detectors **RC111F/111U-M30, 40, 60, 80** or greater diameters may be installed in a virtually horizontal position

(parallel to the ground).

When installed in this position, the flanges of the casing can be used to mount the unit. In either case, the detector and/or pipeline must be mounted in front of or behind detector. Ideally, rigid pipe systems should be used. Avoid drastic reductions as these can result in cavities forming inside the measuring tubes. Where necessary, any reducers should be installed several meters away from the measuring instrument.

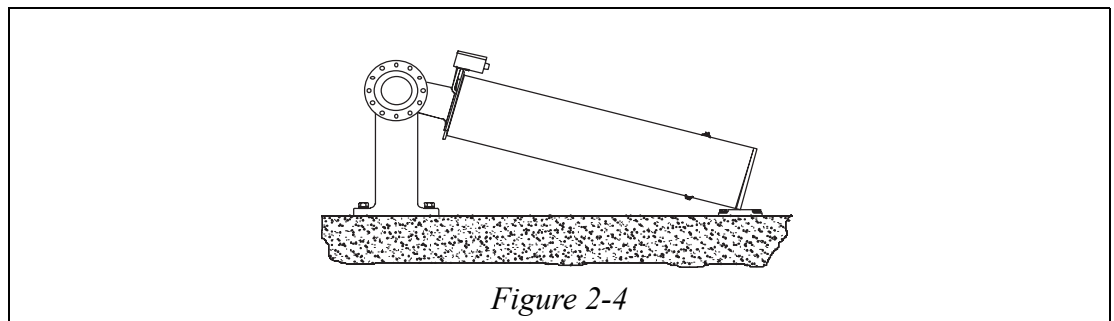

For detector sizes **RC111F/111U-M 30, 40, 60, 80 with parallel tube loops**, straight pipe sections must be provided for before and after the detector **if the medium is fed from a clearly different axis** than given by the inner pipe bend of the detector. For the afore-mentioned detector designs, we recommend that, for the down flow, straight pip-

ing of between 3 - 5 times the diameter of the pipe should be used and, for afflux piping of between 5 - 10 times the pipe diameter should be used in order to avoid significantly different flow velocities resulting for the two measuring tubes. No valves or reducers should be installed between the pipe suspension and the detector. First-rate valves should be installed on the outflow side to ensure that the zero point can be set without difficulty.

Where the smaller **RC111F/111U-M 01, 03 and 04** detectors are concerned, it is important that two valves are installed, one each before and after the detector. As the pipelines have proven to be very instable here, we recommend that you additionally secure these detector sizes to the pipe suspension (feed block). To this end, Azbil Corporation recommends an aluminium bracket that ensures a perfect and simple means of installation.

Installation Plan with Bracket (Side View):

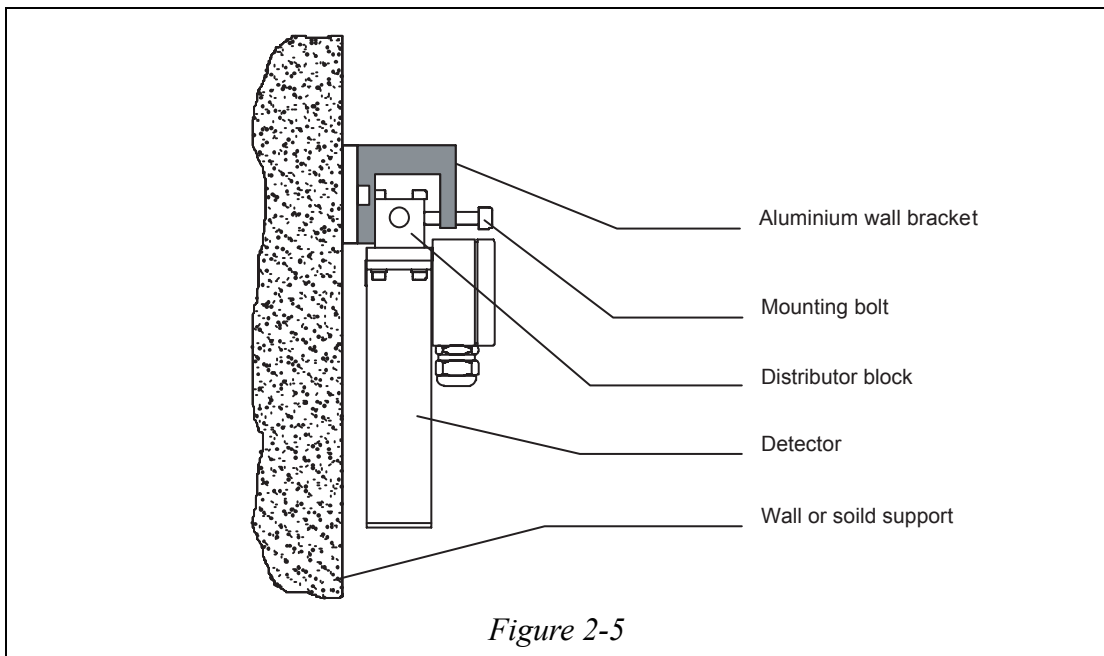

2.1.1 Heating / Filling a detector:

The measuring detector should be heated slowly so that the temperature differential between the medium and the detector is less than 50°C. By way of monitoring this, the temperature in the detector is shown directly on the converter display. **Rapid heating or cooling cycles are not required** at all during the service life of the mechanical appliances.

Caution: Temperature shocks may result in damage occurring to the electromechanical components in the detector. When changing temperature, we recommend a velocity of less than 1°C per second.

Example: Detector temperature: 310°C; temperature of medium: 340°C; - virtually the ideal scenario for filling.

Purging: When scavenging with a cleaning agent, always ensure that the afore-mentioned recommendations are observed.

MEMO

Chapter 3: Electrical Connection of Converter RC111C

3.1 Cable Specifications

The following types of special cables are recommended as wiring cables to be used between the measuring detector and the transmitter and can be readily ordered from the manufacturer:

Type 1: Standard cable. suitable for all appliances

- Permissible cable temperature range: -20...+ 70°C
- 9 core, 4 pairs, individually screened and one wire unscreened
- Material: PVC
- Color: Light blue
- Outer diameter: 12 mm

Type 2: High-temperature cable. suitable for all appliances

- Permissible cable temperature range: -20 °C + 205 °C, for brief intervals up to +230 °C
- 4 pairs of wires, individually screened
- Material: Teflon
- Color: blue
- Outer diameter: 10 mm

3.2 Wiring between the measuring detector and converter

The detector should be connected to the converter using a 9-core screened special cable. It is very important to remember that the functional groups of drive coils and tapped coils are kept separate (each one should have two jointly screened cores; see also enclosed wiring schematic). This will prevent the drive signals from attenuating onto the pickup wires. The maximum distance is 10 meters. Ideally the corresponding measuring cable supplied by Azbil Corporation should be used. In addition, we recommend that, when laying the measuring cable, you should only use cable ducts where no high-voltage or heavy-current cables have been laid (e.g. for motors). Make sure that the wiring points are not connected to external systems such as motors or other sources that are prone to electrical interference. Also ensure that the cable screens cannot cause a short circuit of the detector casing or any other leads or parts. A conductor is used to connect converter terminal No. 10 (galvanically separate zero point inside the appliance) with the detector (see also enclosed wiring schematic). All of the screens are also connected to this electronics terminal.

Notes on Detector Type NT and ETx

⚠ CAUTION

Where **NT** and **ETx** detectors are concerned, the main screen and the single screens are **solely** connected to converter using terminal 10 (galvanically separate zero point inside the appliance) and **not to the detector** but clipped and insulated at this point. Taking this step will prevent potential equalization from flowing through the measurement cable which may affect the measurement.

Notes on Detector Type HT

⚠ CAUTION

For all high-temperature detectors type HT (ceramic insulation), an additional potential equalization lead must be laid between detector and converter. terminal 3 to compensate for hygroscopic conductivity in the ceramic construction materials that are used. This lead will need to be laid on clean ground. The measuring cable screen is **only connected** to the earth screw of the detector if high-temperature detectors are used.

Circuitry:

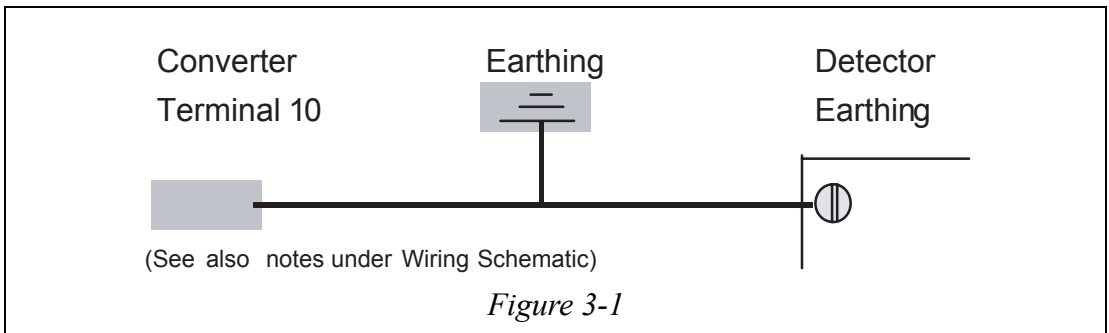

Notes on intrinsically safe installation: **CAUTION**

Only appliances with the relevant name plates of the detector and the converter are in compliance with the data specified in the licence.

Intrinsically safe flow measurement instruments must be connected in compliance with the en-closed wiring schematics.

Please ensure that the appliance is earthed as per the regulations and in compliance with the enclosed wiring schematics.

The detector cable must also be suited for use in the relevant temperature range.

All intrinsically safe cables must be laid separately from all other cables. Ensure that they correspond to the relevant temperature category and the maximum permissible detector temperature, which is also specified on the serial number plate of the detector. All of the electric connections performed by the user must comply with the national and local regulations.

MEMO

Chapter 4: Installation of the Converter

The Converter transmitter should be installed in locations where the ambient temperature ranges from between -20 and +60°C. For temperatures outside this range, please consult the manufacturer. Avoid installing in places which are subject to extreme vibrations. Furthermore, the transmitter must **not be exposed to direct sunlight**.

The detector and converter are calibrated by the manufacturer as one system. Please therefore ensure that the serial numbers tally with the relevant measuring unit stated in the calibration certificate or on the serial number plate.

4.1 Connecting the Power Supply

The converter is equipped with a 24 VDC mains supply.

For trouble-free operation, the power supply must maintain the specified nominal voltage of + - 10%.

When connecting the transmitters, always ensure that the power supply is switched off. The earthing for the power supply should be connected using the relevant converter earthing.

CAUTION

Wrongly connecting the earthing will disable the intrinsically safe features!
All outputs are galvanically separated from the auxiliary power and gating circuit.

MEMO

Chapter 5: Operation and Programming

This section deals with the operation of and settings for the converter.

5.1 Basic Operation and Settings Principle

Two magnetic switches and a twin-line LCD each consisting of 16 characters are located on the converter. The delivered magnetic sticks are for activating the magnetic switches. By holding a stick against the window pane, over the places where the arrows at the front foil are marked, the switch will be activated. It is not necessary to look for the magnetic polarization of the magnetic sticks, since the magnetic switches are realized by bipolar HALL-sensors, they will work bidirectional.

Using the switches, it is possible to set every single operating parameter or to activate the appliance functions.

- Measurement range
- Analog output span
- Physical units
- Low-flow cut-off
- Diagnostic functions for measurement and output
- Flow measurement calibration
- Automatic zeroing
- Measurement damping
- Totalizer reset
- Run-time counter reset

The converter is operated through the menu. Once in the menu, the current functions of the two magnetic switches are displayed in the LCD display.

If the letters SET appear in the display over the key located below it, activating this key will set the parameters or activate the reset.

Pressing NEXT will take you to the next menu point in the display.

To reach the basic set-up, which helps to adjust the transmitter to the relevant measuring sensor, press both magnetic switches for a few seconds at the same time.

All of the settings are saved in a non-volatile EEPROM memory that guarantees data security for a period of over 10 years.

Important Note!

⚠ CAUTION

Prior to delivery, the values in the basic set-up are calibrated by the manufacturer for the relevant measuring detector in accordance with the serial number plate of the converters and do not need to be programmed. Changing these values can significantly impair the accuracy of the measurements and should only be performed by trained users or in consultation with the nearest service centre or the manufacturer. To access the applications set-up, activate the right-hand magnetic switch (in the measurement data display) for approx. 5 seconds. With the help of the menu steps that follow, the converter can be adjusted by the user for his specific application.

To activate Diagnostic Mode, activate the left-hand magnetic switch (in the measurement data display, also for 5 seconds). This enables you to check the key functions of the measuring instrument prior to its initial operation.

5.1.1 Start -up Display



After power up, the start-up display will show the program version number and the appliance address (0 to 15) for the serial data interface for a period of 5 seconds. The appliance address should normally be set to “00”. If several appliances are operated in parallel on one serial data interface, you will need to allocate various appliance addresses.

5.1.2 Measurement Display

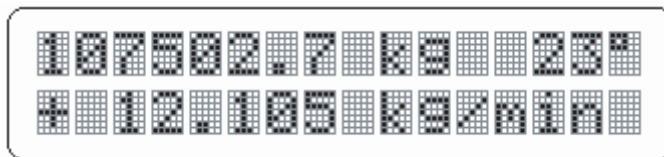

The following measurement values can be read off the local display of the converter:

- Current flow rate display (lower display line)
- Current direction of flow +/- (lower display line, left)
- Current mass totalizer level (upper display line)
- Current detector temperature (upper display line, right)

The mass totalizer units are shown in Si units kg, t (kilogram, tonne) or in the US unit lb (pounds).

The flow rate units are given as kg/min, kg/h, t/h or lb/min.

The temperature units that are displayed are °C (Celsius) or °F (Fahrenheit).

5.2 User Set-up

To access the User set-up, activate the right-hand magnetic switch for approx. 5 seconds.

5.2.1 Resetting the Mass Totalizer

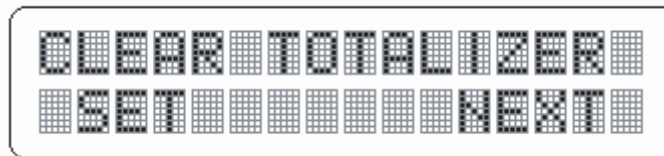

The mass totalizer will reset to Zero if the SET key is pressed for 5 seconds with the above display showing.

5.2.2 Zeroing

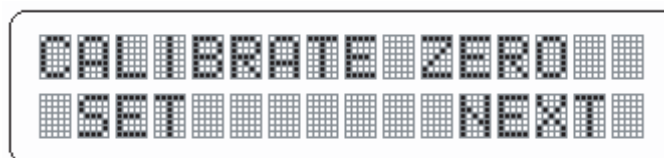

Zeroing is automatically performed if the SET key is held down for approx. 5 seconds.

The actual zeroing process takes about 20 seconds. During this time, the display cannot be used further. The words "ZEROING ACTIVE" will appear in the display. An exact description of how to perform the zeroing can be found in the chapter entitled "ZEROING PROCEDURE".

5.2.3 Measurement Value Damping



Press the SET key to set the reaction time and various measurement damping values. The numerical value that is displayed indicates that digital filtering is being applied for this number of sequential measurement values.

5.2.4 Rate and Quantity Unit Display



The flow rate and totalizer units can be set using the menu point entitled SET. Regardless of the range that is set, the following units can be selected: g/min, kg/h, t/h. The totalizer display automatically sets to kg or t.

5.2.5 Low -flow Cut -off

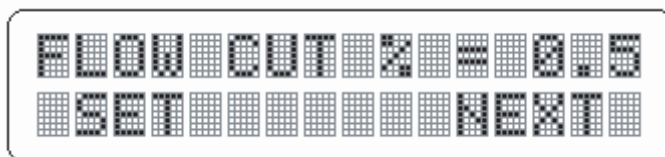

Here, a flow rate can be set as a% of the set RANGE. Below this threshold, no flow rate will be displayed or counted.

5.2.6 Allocation of Analog Output Function



The 4-20 mA output can be allocated either the current flow rate or the temperature.

5.2.7 Span Analog Output

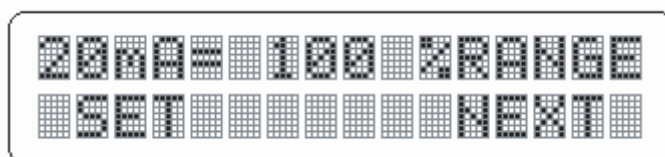

In output mode “Temperature”, the 4 to 20 mA span corresponds to 150 °C to +360 °C. In output mode “Flow Rate”, the ultimate flow rate value can be set in the next display. Flow rate “Zero” corresponds to 4 mA. The ultimate value of the analog output can be scaled using the SET key. The percentage value relates to the ultimate value of the measurement range in kilograms per second that is set when in RANGE display.

5.3 Basic Settings

With the measurement value display active, press both magnetic switches for approx. 5 seconds to switch to basic settings mode.

The following displays show the settings that have been determined during the manufacturer's calibrations for the connected measuring detector and which are recorded in the calibration certificate enclosed to your Azbil Corporation measuring system (the values depicted are solely intended as examples and may vary from those found in your measuring system).

5.3.1 Scaling - M

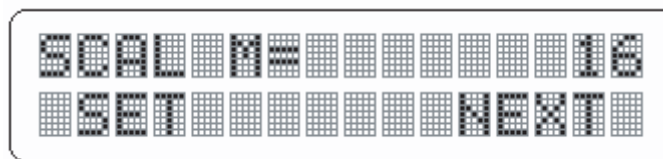

The image shows a two-line LCD display. The first line displays 'SCALE M = 1.18' and the second line displays 'SET NEXT'.

The scaling multiplier for mass flow calibration. The actual valid value for the measuring detector can be found in the calibration certificate supplied with the appliance.

5.3.2 Scaling - D

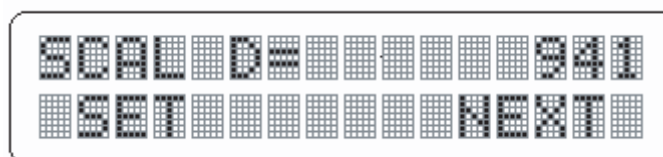

The image shows a two-line LCD display. The first line displays 'SCALE D = 941' and the second line displays 'SET NEXT'.

The scaling divider for mass flow calibration. The actual valid value for the measuring detector can be found in the calibration certificate supplied with the appliance.

5.3.3 Device Hi -limit Range

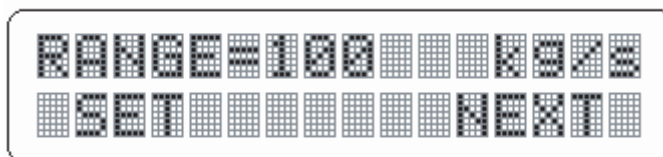

The image shows a two-line LCD display. The first line displays 'RANGE = 100 kg/s' and the second line displays 'SET NEXT'.

Using the SET function, all of the device hi-limit ranges can be set for flow measurement. To achieve this, the detector range must lie within the displayed RANGE otherwise the words OVERFLOW ERROR will be displayed during operation.

5.3.4 Temperature Compensation

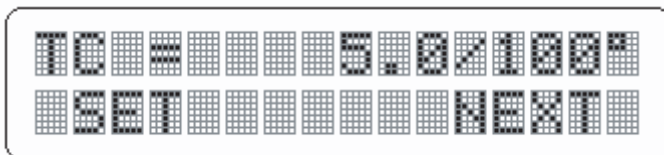

When set, this parameter will compensate for temperature-related changes in the measuring sensitivity of the measuring detector. The unit applied is %/100°C.

5.4 Diagnostics Display Primary Detector Signals

The display indicates the current values of the phase shift that has been measured as well as the value of the digital analog converter for measuring temperature

The values range between 32768... 32768 or 0... 255.

5.4.1 Diagnostics - Measuring Frequency

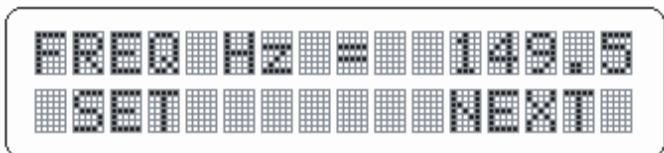

Here, the number of measurements is displayed that are carried out per second.

The value depends on the flow rate and the density of the medium in the measuring tubes.

5.4.2 Diagnostics - Analog Output

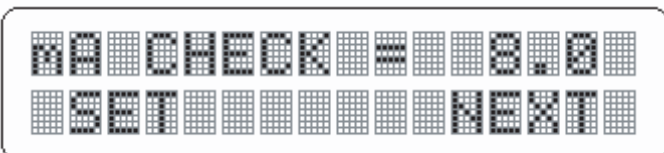

For testing purposes, the SET button can be used to set the output to the pre-set values ranging from between 4 and 20 mA. The output value can be verified using an ampere meter connected to both terminal 13 and 14.

Pressing both set keys at the same time will switch the appliance to continuous test mode. A periodic rising signal will be emitted which ranges between 4 and 20 mA and lasts for around 30 seconds.

Please Note!

 **CAUTION**

The test function described here must not be performed when measurements are being taken if the measuring device is being operated as an actual value converter for a closed loop circuit. In this case, the flow rate controller will be sent an invalid actual value signal.

5.4.3 Diagnostics - Pulse Output

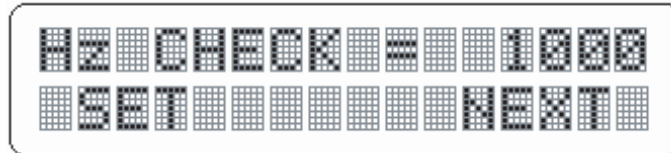

The displayed frequency is indicated when the pulse output is connected if the pulse divider is bridged 1: 1 in the transmitter electronics. If not, the divider should be taken into account when the frequency is measured at terminals 12 and 13.

5.4.4 Detector Diagnosis

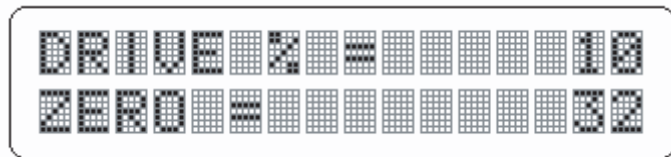

The percentage of power dissipation in the detector’s drive circuit is shown as is the zero point that is calculated during the detector zeroing procedure.

5.4.5 Display Run -Time Counter

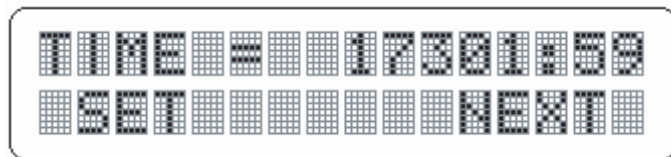

The display indicates in hours and minutes the amount of time the measuring device has been in operation. In the example above, the operating time is 17301 hours and 59 minutes. The SET key can be used to reset the counter.

MEMO

Chapter 6: ZEROING PROCEDURE

Once the measuring detector has been installed inside the pipeline and the converter has been electrically wired, a zeroing procedure will need to be run. Zeroing is done with the help of the local display and takes around 20 seconds. Once this is completed, the flow rate measurement system will continue to run on the basis of the newly defined zero point.

How to Proceed:

Perfuse the measuring detector with as high a flow rate as possible until the measuring tubes are filled without any gas bubbles/condensation and the unit is running normally.

Switch off the flow rate.

Close the check valve in the pipeline for zeroing (ideally downstream from the measuring detector).

Using the local display in the zeroing menu (see display matrix) and the SET function, begin the zeroing procedure. While the appliance is performing the zeroing procedure, the words “ZEROING ACTIVE” will be displayed.

Once the zeroing is completed, the newly defined zero value will be indicated in the display.

Press NEXT. The measuring device is now ready for operation.

The zero value that has just been defined is saved to memory and the valve can now be reopened.

Please Note!

CAUTION

Since the zero point value is buffered to a non-volatile memory (EEPROM), the measuring device will remain ready for operation even if the power supply is shut down and then re-started. No new zeroing is required.

To ascertain whether or not a new zeroing procedure needs to be performed on the measuring device after it has been idle for a long period of time it is possible to compare the values indicated in the display for both PHASE and ZERO (see instruction matrix entitled “Diagnosis”). For this to happen, the flow rate must be shut down and the valve closed. The current phase should tally with the stored value (zero).

If major changes occur, simply re-run the zeroing procedure!

 **CAUTION**

When greater medium temperatures are concerned or the gas content or viscosity is high, the zero point will only change minimally. For this reason, it is recommended that all zeroing procedures are performed under operating conditions.

Chapter 7: ERROR DIAGNOSTICS

Malfunctions in the operation of the device are detected automatically and immediately by the signal processor located inside the device. An error message is generated as a short text which can be found in the lower display line.

RAM CHECK ERROR:

An error has occurred in the RAM memory. At least one memory cell cannot be written or read properly. When this error arises, the measuring program is subjected to continuous start-up. The device is no longer operational. The problem can only be remedied by replacing the controller board.

IIC - BUS ERROR:

The serial data transfer to non-volatile parameter memory has failed or the memory chip is defective. The problem can only be remedied by replacing the controller board.

OVERFLOW ERROR:

A number range overflow has occurred during calculation of the arithmetic values. To remedy this problem, a check should be performed as to whether the flow rate is not too large for the measuring detector being used or whether the measuring range that has been set is sufficient.

TEMP. ° ERROR:

At least one of the wires between the PT100 temperature sensor (in the measuring sensor) and the transmitter has been cut or the PT100 sensor is defective. To diagnose the problem, first check the wiring between the transmitter and the measuring detector. Should the problem still be present, disconnect the PT100 wires connected to the measuring detector and take an ohmmeter to the measuring detector terminals and check whether PT100 has been cut. If PT100 is defective, the measuring detector will need to be sent in to the nearest service centre for repair.

TOTL. OVERFLOW:

An overflow has occurred in the 7-digit totalizer, i.e. the counter has exceeded the figure 9999999 and the count has been reset at zero. To cancel this message, the totalizer must be reset to zero.

Chapter 8: Adjusting the Converter

8.1 Setting the Frequency Divider, Pulse Output and Measuring Frequency

For the purpose of making these settings, a 14-pole, double-row pin bar has been provided in controller board M 521 (see Number 5 in the figure below) which can house a jumper that defines the dividing ratio. After removing the casing cover and glass window, the pin bar can be accessed from the side of the block of boards without having to disassemble the individual boards.

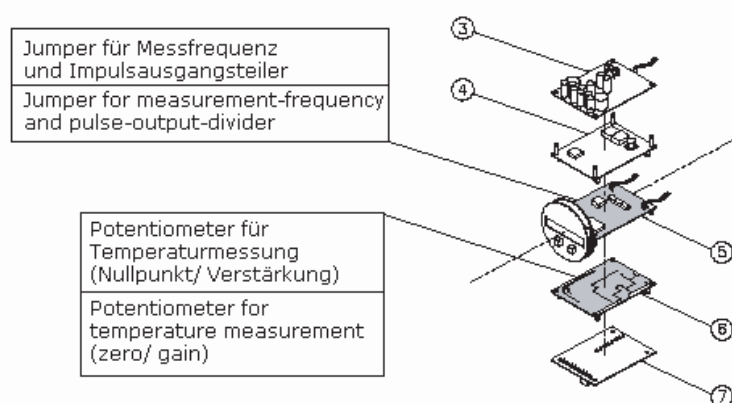

Both the adjustable decade dividers and the relevant position for these can be seen in the following illustration.

The measuring frequency for the phase measurement can be adjusted using a jumper on a 3-pole, single-row pin bar which has been configured next to the pin bar for the pulse divider. Two jumper possibilities are available - as can be seen by the illustration below. one for 4 MHz counting frequency and one for 2 MHz counting frequency. The factory setting can be found in the calibration certificate for the measuring detector and only needs to be adjusted if the transmitter has not been pre-configured at the factory (replacement de-livery). Changing the counting frequency of a calibrated mass flow sensor will result in the output signals changing by a factor of 2 when the counting frequency is changed from 2 to 4 MHz, and by a factor of 0.5 if the change made is from 4 to 2 MHz.

For this reason, in order to correct this, the original value M for the calibration factor of the flow rate measurement will need to be adjusted by changing the setting to half the original value in the first instance and twice the value in the second case.

The table below shows the adjustable pulse settings in line with the RANGE of the converter. The set RANGE can also be found in the calibration certificate supplied with the measuring detector.

⚠ CAUTION

For all US units, the number of pulses is given in lbs and not in kg!

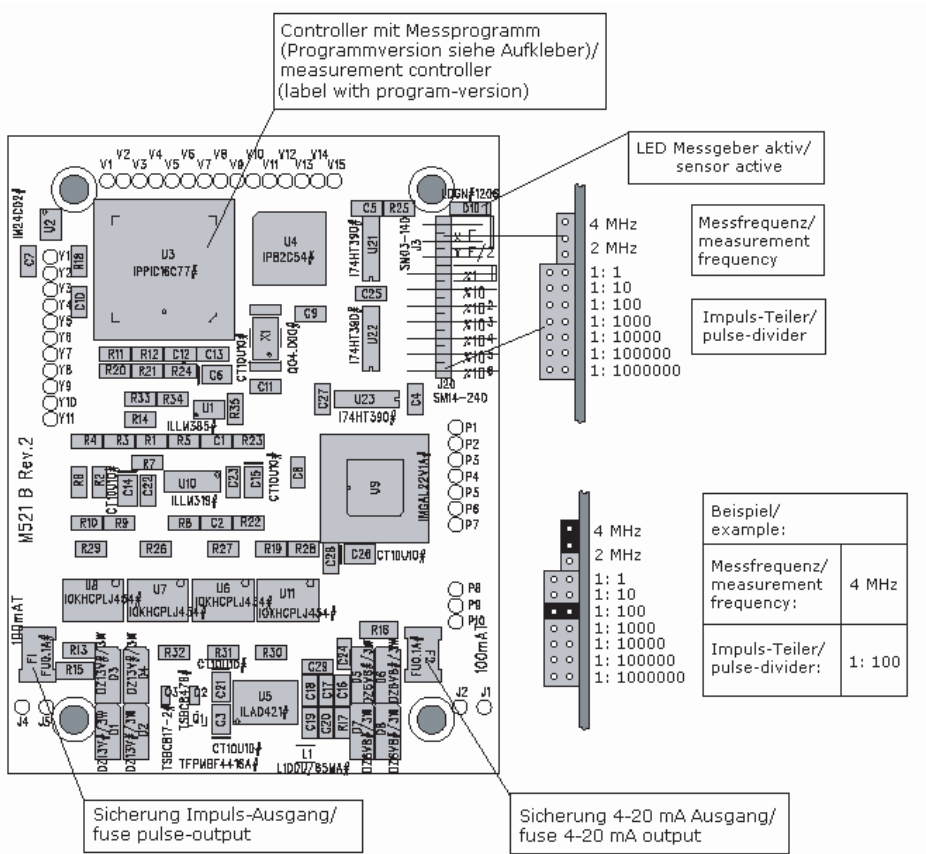

Table 8-1

Range	pulses/kg (lb)							
	for divider	1:1	1:10	1:100	1:1000	1:10000	1:100000	1:1000000
0 - 0.06 kg/min		10000000	1000000	100000	10000	1000	100	10
0 - 0.6 kg/min		1000000	100000	10000	1000	100	10	1
0 - 6 kg/min		100000	10000	1000	100	10	1	0.1
0 - 60 kg/min		10000	1000	100	10	1	0.1	0.01
0 - 600 kg/min		1000	100	10	1	0.1	0.01	0.001
0 - 6000 kg/min		100	10	1	0.1	0.01	0.001	0.0001
0 - 60000 kg/min		10	1	0.1	0.01	0.001	0.0001	0.00001

On the jumper array for output-divisor, **only one divider may be bridged in each case.**

Chapter 9: Troubleshooting

Important Note!

CAUTION

Once the casing cover is removed, the contact voltage proof is disabled which can result in persons being exposed to electric shocks. For this reason avoid all direct contact with the electronic components. All interventions on the device while still connected to the power supply should only be performed by skilled workers using well insulated tools.

Never open the device in a hazardous area when it is still connected to the power supply!

Fuses may only be replaced on the power supply board after the power supply has been disconnected.

9.1 Error status of output

9.1.1 Pulse Output

No pulse output until the error has been corrected

9.1.2 Current Output

The current is set as pre-defined value of 22mA

9.2 Notes on Troubleshooting

9.2.1 No Display available on the Device

Check whether the power supply voltage is within the permissible range: for DC versions the range is 20 to 30 volts on the supply terminals.

Check the fuses on the power supply board using an ohmmeter and, where necessary, replace them with the same type of fuse.

Check whether the LED on the controller board is flashing or not. If yes, the LCD display may be defective or one of the connections to the display board has been cut.

If the problem cannot be remedied, a systems error may have occurred and the device will need to be sent to the nearest service centre for inspection or repair.

9.2.2 Error Display “Pickup Error”

Check whether the measuring detector has been wired to the converter as described in the wiring schematics.

Check whether the following voltage is available for the detector terminals:

Table 9-1

Terminals	Voltage
1 - 2	approx. 0.7 VAC
3 - 4	approx. 120 mVDC (at 20 °C)
3 - 5	as 3 - 4
6 - 7	10... 120 mVAC
8 - 9	as 6 - 7

Check whether the resistance values can be measured at the detector terminals. (Remove the converter cable before doing this):

Table 9-2

Terminals	Resistance
1 - 2	10... 50 Ohm
3 - 4	approx. 108 Ohm (at 20 °C)
3 - 5	as 3 - 4
6 - 7	10... 120 Ohm
8 - 9	as 6 - 7

If a circuit is interrupted, a defect must have occurred in the measuring detector. In this instance, please send in the detector to the Azbil Corporation Offiliate for repair and indicate what defect was detected.

Notes on repairs

Measuring detectors which are returned to the manufacturer will only be accepted if the following items have been observed:

CAUTION

The detectors must be cleaned first. A copy of a non-contamination certificate must always be enclosed (this form can be obtained from the manufacturer directly and is to be accompanied with a description of the error and the chemical, physical and toxicological properties of the measured liquid. If applicable, also ensure that the safety data sheet is enclosed.

All residual matter must be removed from the sensor if the measure liquid is poisonous, corrosive, carcinogenic or otherwise hazardous to personal health. Flowmeters used for measuring radioactive matter or that cannot be fully freed of carcinogenic matter may not be sent in for repair.

Should any details on the measures liquid be missing, or if the device has not been sufficiently cleaned, it will not be accepted for repair. It is recommended that you also send in the converter, even if it has no obvious defects. When re-calibrating, both devices can be tested together and exactly tuned to each other. Failing this, it should be remembered that on return of the detector, the new calibration values for the measuring detector must be in line with the calibration certificate before beginning the initial operation of the measuring device in the converter.

Detectors that are filled with a medium that has hardened at room temperature may be sent in to the manufacturer but cannot be calibrated any more on a test bench.

MEMO

Chapter 10: Technical Data - Converter

Voltage Supply:

nominal 24 VDC, 20 to 30 VDC, 7 Watt

Casing Material:

Cast aluminium

Protection:

IP66 (EN 60529)

Ambient Temperature:

-20... +55 °C

Cable Glands:

3/4" NPT Ex-d cable glands

Galvanic Isolation

Outputs against auxiliary energy and measuring circuits

Current Output

4..20 mA adjustable, galvanic isolated, $R_L < 450 \text{ Ohm}$.

Temperature coefficient 0.01%v.E./°C

Accuracy: 0.05% v.E.

Pulse Output Open Collector

$f_{max} = 10000\text{Hz}$

$U_{max} = 24 \text{ V}$,

$I_{max} = 10\text{mA}$, |Pull-up resistor required, minimum resistance 500 Ohm at 5V, 3000 Ohm at 24V, galvanic isolated

Hi/Lo ratio 1:1, number of pulses adjustable

Data Backup

EEPROM backs up the parameters in case of a power failure. Backups are made for the totalizer and run-time counter every ten minutes.

LCD Display

2 lines, 16 characters, alphanumeric, font size 5mm

MEMO

Chapter 11: Technical Data - Measuring Detector

The technical data for the measuring detector can be found in the separate product data sheets.

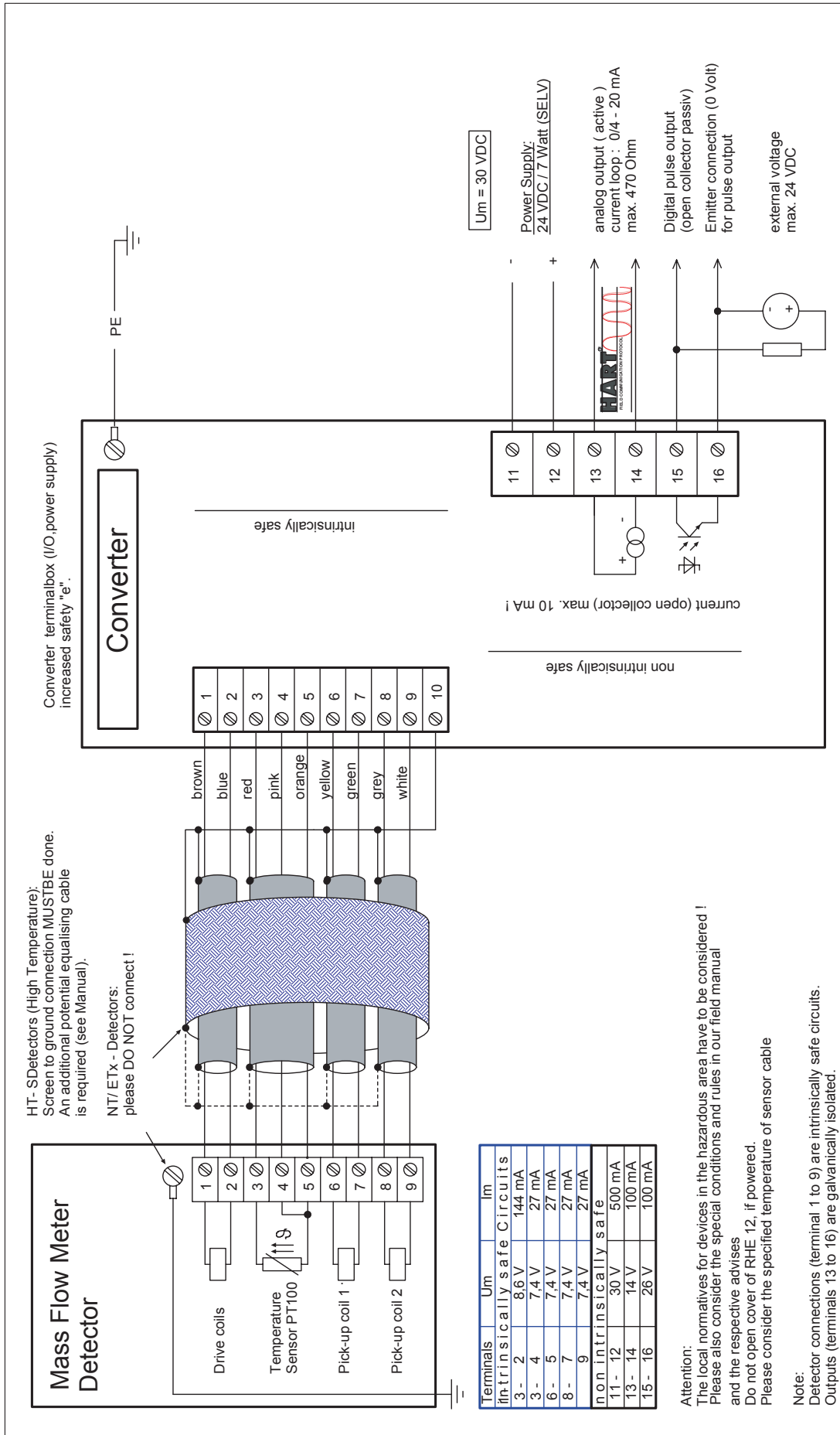

Chapter 12: Display Matrix

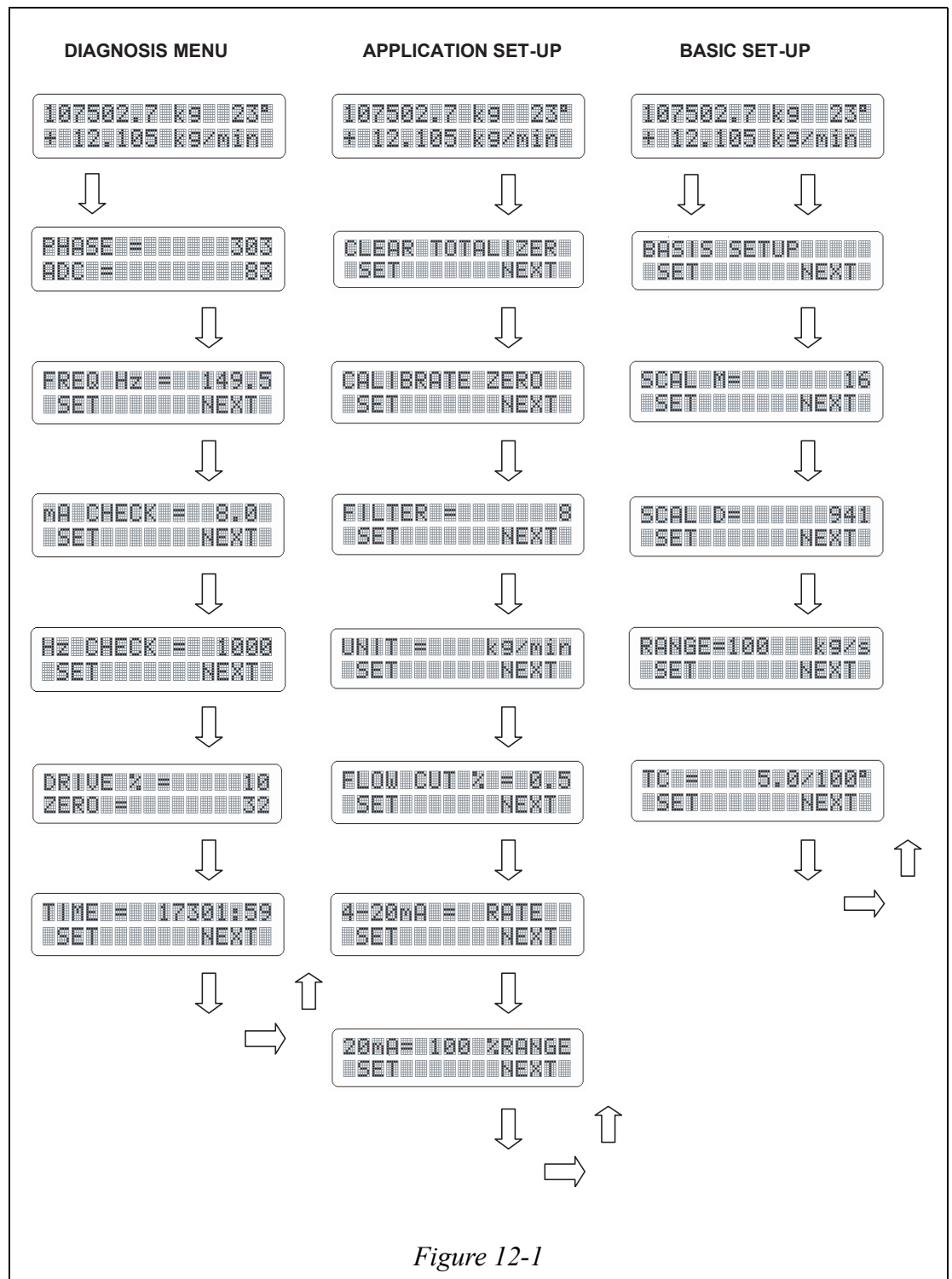

Figure 12-1

Safety Instructions for Installing the Device in Hazardous Areas:**General Description:****⚠ CAUTION**

The Coriolis mass flowmeter, which comprises the system components detector and converter has been constructed and produced in accordance with the ATEX 94/9/CE guideline and with reference to the following standards: EN50014, EN50018, EN50019, EN50020.

The measuring system consists of a measuring detector and converter that are connected to each other via a multicore electric cable.

The following points should be observed:

The measuring system should be installed and operated in compliance with the applicable standards relating to electrical installations in hazardous areas.

Please read the User's Manual before installing.

All assembly work, electrical installations, operation and maintenance work must be performed by qualified workers who have been trained in handling products in hazardous areas.

All national regulations pertaining to the installation, maintenance and repair of instruments in hazardous areas must be observed at all times.

The required temperature class based on the ambient temperature and liquid temperature must correspond to the values on the Ex type label and the tables listed above. Wherever possible, the device should never be opened. Should you nevertheless open the converter electronics, please ensure that the power supply has been disconnected and allow the unit to cool down for at least ten minutes.

Never open the device while it is still connected to a power supply.

Always use a moist cloth or antistatic products to clean the converter dome cover window.

The cable connection between the detector and the converter remote unit is intrinsically safe. Only use cables which are supplied by (SLI2Y(ST)Y (4x(2x0.5 mm²)+1x0.5 mm²).

When running the unit at minus 30 °C, a steel-reinforced cable must be used:

LISO-ST-C-A-Y 2 x (2x AWG 22 PIMF) + 1 x (2 x AWG 18 PIMF) + 1 x (3 x AWG 22 DIMF), blue.

The maximum length of cable between the detector and the converter remote unit is 5 meters.

If the cable is to be installed close to the detector, provisions must be taken to ensure that the cable temperature never exceeds 70 °C.

For this reason, care must be taken to ensure that no loose cable lengths are left which may come into contact with the hot sensors surface or any other hot objects.

⚠ CAUTION

When establishing a power supply and input and output leads, Type EEx-d IIC cable glands must be used which have been certified in accordance with to EN 50014 and EN 50018.

All unused orifices in the casing must be sealed off using blind union pieces which have been certified in accordance with EN 50014 and EN 50018.

Details on the protection class can be found on the EX type plate (see also “Markings” which can also be found in this manual).

In accordance with the specifications given on the Ex type plate, the instruments are suited for areas where inflammable surroundings may emerge as a result of air, gas vapours and dust mixing.

The instruments are not suited for use in mines.

The detector (Protection class: intrinsically safe, ia) may be installed in hazardous areas 0, 1 or 2.

The converter remote unit falls under protection class: pressure-proof housing, intrinsically safe, d [ia]), and may be installed and operated in hazardous areas Zone 1 or 2.

The converter is classified as temperature class T6 (55 °C).

Depending on the entire remote unit used, the measuring system can also be installed in a hazardous area. (Please consult the following tables).

Table 12-1

Type of Unit	Place of Installation:	Group/Category	Protection Class
Detector	Haz. area, Zone 0, 1 or 2	II 1 G	EEx ia II C
Converter	Haz. area, Zone 1 or 2	II 2 (1) G	EEx d [ia] II C

Table 12-2

Haz. Area Group II	Zone EN60079 - 14	Category as per 94/9/CE guideline
Gas, mist or vapour	Zone 0	1 G
Gas, mist or vapour	Zone 1	2 G
Gas, mist or vapour	Zone 2	3 G

Markings:

The section on Markings comprises two sections:

1. The **specific markings** show which inflammable surroundings and hazardous areas the instrument is suited for depending on the protection class taken. The identification number for the relevant certifying authority is also stated here.
2. The **additional markings** contain vital information for the safe use of the instrument. These markings are in compliance with European standard EN 50014 governing the operation of electrical products in potentially explosive surroundings.

12.1 Specific marking:

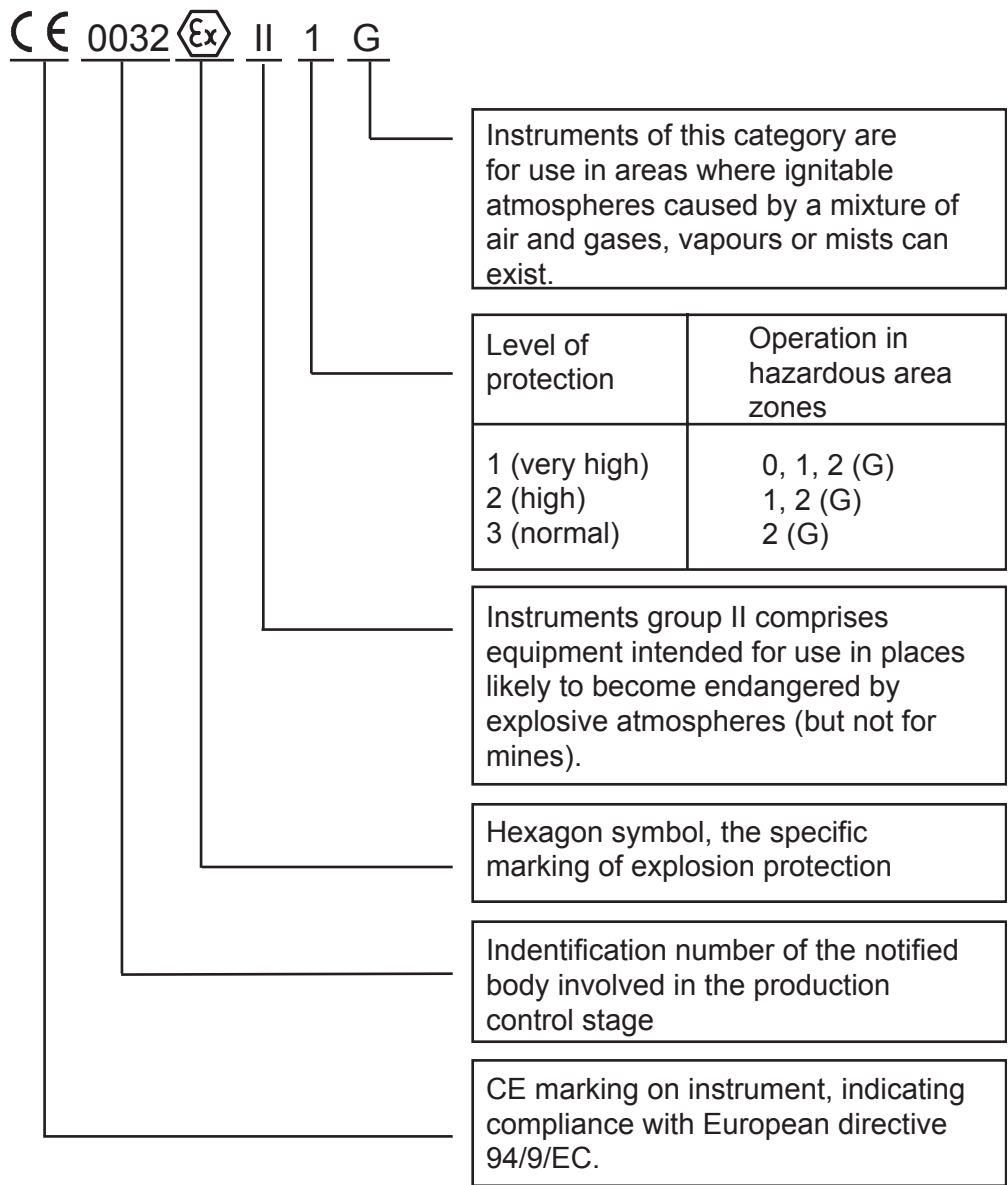

Note: **CAUTION**

If the number, indicating the level of protection is put into brackets, the instrument can be installed in safe area only, but can be connected to the indicated category instruments in the hazardous area!

12.2 Additional marking:

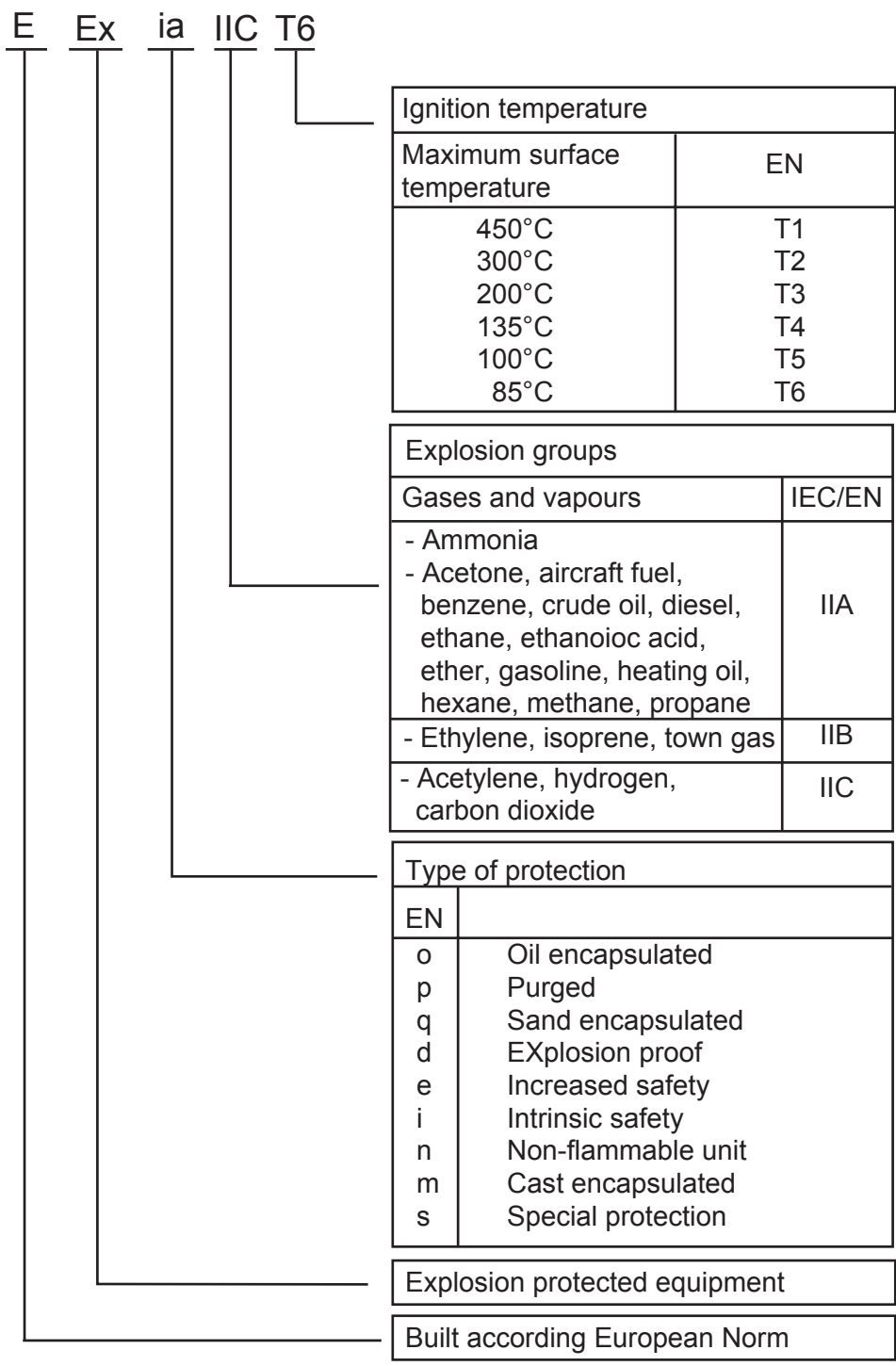

Electrical characteristics:**Intrinsically safe detector circuits, when connected to converter:**

Table 12-3

Circuit name	Terminals	U _o [V]	I _o [mA]	L _o [mH]	C _o [uF]	P _o [mW]
Drive coil	1 - 2	8, 6	141	1,6	4,8	310
PT100 sense	3 - 4	7,4	29	35	10	54
PT100 current	3 - 5	7,4	29	35	10	54
Sense coil 1	6 - 7	7,4	29	35	10	54
Sense coil 2	8 - 9	7,4	29	35	10	54

Power supply circuit, the converter (galvanic isolated):

Remote unit type	Rated voltage	Rated frequency	Maximum voltage (U _m)	Rated power
Converter	24 VDC	DC	30 VDC	7 VA

Temperature tables:**Measurement fluid temperatures (at ambient temperature 55°C): Max. Fluid temperature [°C] in temperature class**

at T _a = 60°C	T6	T5	T4	T3	T2	T1
Detector NT	50	65	100	120	-	-
Detector ET	50	65	100	165	210	-
Detector HT	50	65	100	165	260	350

Min. fluid temperature [°C] in temperature class

at T _a = 60°C	T6	T5	T4	T3	T2	T1
Detector NT	-20	-20	-20	-20	-20	-20
Detector ET	-45	-45	-45	-45	-45	-45
Detector HT	-20	-20	-20	-20	-20	-20

⚠ CAUTION

With the temperatures given, and for a certain temperature class the detector components will not be subjected to any non-permissible temperatures.

Converter ambient temperature Ta:

DECLARATION OF CONFORMITY

Remoteunittype	Min. Ta [°C]	Max. Ta [°C]	Temperature class
Converter	-20	+55	T6



DECLARATION OF CONFORMITY

We, the offerer:

**RHEONIK® Meßgeräte GmbH, Rudolf Diesel Str. 5, 85235
Odelzhausen, Germany**

acknowledge our sole responsibility, that the product:

Kind of equipment: Coriolis Mass Flow Meter
Type designation: RHM® massflow sensor
RHE® remote unit/flow transmitter

in accordance with EMC Directive 89/336/EEC and it´s amendments 91/263/EEC,
92/31/EEC, 93/68/EEC and 93/97/EEC,
is in compliance with the following norm(s) or document(s):

Technical regulations: EN 61000-6-2, EN 61000-6-3, EN 6100-6-4

in accordance with the Low Voltage Directive 73/23/EEC and it´s amendment 93/68/EEC,
is in compliance with the following norm(s) or document(s):

Technical regulations: EN 61010-1

in accordance with the ATEX Directive 94/9/EEC,
is in compliance with the following norm(s) or document(s):

**Technical regulations: 1) EN 50014, EN 50018, EN50019, EN50020
2) EN 50284**

in accordance with the Pressure Vessel Directive 97/23/EEC,
is in compliance with the following norm(s) or document(s):

Technical regulations: AD2000-A4, DIN3840

1 January 2003

RHEONIK Meßgeräte GmbH
Rudolf Diesel Str. 5
85235 Odelzhausen

Michael Küppers
Managing Director, RHEONIK GmbH,
Manufacturer

MEMO

Terms and Conditions

We would like to express our appreciation for your purchase and use of Azbil Corporation's products.

You are required to acknowledge and agree upon the following terms and conditions for your purchase of Azbil Corporation's products (system products, field instruments, control valves, and control products), unless otherwise stated in any separate document, including, without limitation, estimation sheets, written agreements, catalogs, specifications and instruction manuals.

1. Warranty period and warranty scope

1.1 Warranty period

Azbil Corporation's products shall be warranted for one (1) year from the date of your purchase of the said products or the delivery of the said products to a place designated by you.

1.2 Warranty scope

In the event that Azbil Corporation's product has any failure attributable to azbil during the aforementioned warranty period, Azbil Corporation shall, without charge, deliver a replacement for the said product to the place where you purchased, or repair the said product and deliver it to the aforementioned place. Notwithstanding the foregoing, any failure falling under one of the following shall not be covered under this warranty:

- (1) Failure caused by your improper use of azbil product (noncompliance with conditions, environment of use, precautions, etc. set forth in catalogs, specifications, instruction manuals, etc.);
- (2) Failure caused for other reasons than Azbil Corporation's product;
- (3) Failure caused by any modification or repair made by any person other than Azbil Corporation or Azbil Corporation's subcontractors;
- (4) Failure caused by your use of Azbil Corporation's product in a manner not conforming to the intended usage of that product;
- (5) Failure that the state-of-the-art at the time of Azbil Corporation's shipment did not allow Azbil Corporation to predict; or
- (6) Failure that arose from any reason not attributable to Azbil Corporation, including, without limitation, acts of God, disasters, and actions taken by a third party.

Please note that the term "warranty" as used herein refers to equipment-only-warranty, and Azbil Corporation shall not be liable for any damages, including direct, indirect, special, incidental or consequential damages in connection with or arising out of Azbil Corporation's products.

2. Ascertainment of suitability

You are required to ascertain the suitability of Azbil Corporation's product in case of your use of the same with your machinery, equipment, etc. (hereinafter referred to as "Equipment") on your own responsibility, taking the following matters into consideration:

- (1) Regulations and standards or laws that your Equipment is to comply with.
- (2) Examples of application described in any documents provided by Azbil Corporation are for your reference purpose only, and you are required to check the functions and safety of your Equipment prior to your use.
- (3) Measures to be taken to secure the required level of the reliability and safety of your Equipment in your use

Although azbil is constantly making efforts to improve the quality and reliability of Azbil Corporation's products, there exists a possibility that parts and machinery may break down. You are required to provide your Equipment with safety design such as fool-proof design,*1 and fail-safe design*2 (anti-flame propagation design, etc.), whereby preventing any occurrence of physical injuries, fires, significant damage, and so forth. Furthermore, fault avoidance,*3 fault tolerance,*4 or the like should be incorporated so that the said Equipment can satisfy the level of reliability and safety required for your use.

*1. A design that is safe even if the user makes an error.

*2. A design that is safe even if the device fails.

*3. Avoidance of device failure by using highly reliable components, etc.

*4. The use of redundancy.

3. Precautions and restrictions on application

3.1 Restrictions on application

Please follow the table below for use in nuclear power or radiation-related equipment.

	Nuclear power quality*5 required	Nuclear power quality*5 not required
Within a radiation controlled area*6	Cannot be used (except for limit switches for nuclear power*7)	Cannot be used (except for limit switches for nuclear power*7)
Outside a radiation controlled area*6	Cannot be used (except for limit switches for nuclear power*7)	Can be used

*5. Nuclear power quality: compliance with JEAG 4121 required

*6. Radiation controlled area: an area governed by the requirements of article 3 of "Rules on the Prevention of Harm from Ionizing Radiation," article 2 2 4 of "Regulations on Installation and Operation of Nuclear Reactors for Practical Power Generation," article 4 of "Determining the Quantity, etc., of Radiation-Emitting Isotopes," etc.

*7. Limit switch for nuclear power: a limit switch designed, manufactured and sold according to IEEE 382 and JEAG 4121.

Any Azbil Corporation's products shall not be used for/with medical equipment.

The products are for industrial use. Do not allow general consumers to install or use any Azbil Corporation's product. However, azbil products can be incorporated into products used by general consumers. If you intend to use a product for that purpose, please contact one of our sales representatives.

3.2 Precautions on application

you are required to conduct a consultation with our sales representative and understand detail specifications, cautions for operation, and so forth by reference to catalogs, specifications, instruction manual, etc. in case that you intend to use azbil product for any purposes specified in (1) through (6) below. Moreover, you are required to provide your Equipment with fool-proof design, fail-safe design, anti-flame propagation design, fault avoidance, fault tolerance, and other kinds of protection/safety circuit design on your own responsibility to ensure reliability and safety, whereby preventing problems caused by failure or nonconformity.

- (1) For use under such conditions or in such environments as not stated in technical documents, including catalogs, specification, and instruction manuals
- (2) For use of specific purposes, such as:
 - * Nuclear energy/radiation related facilities
[When used outside a radiation controlled area and where nuclear power quality is not required]
[When the limit switch for nuclear power is used]
 - * Machinery or equipment for space/sea bottom
 - * Transportation equipment
[Railway, aircraft, vessels, vehicle equipment, etc.]
 - * Antidisaster/crime-prevention equipment
 - * Burning appliances
 - * Electrothermal equipment
 - * Amusement facilities
 - * Facilities/applications associated directly with billing
- (3) Supply systems such as electricity/gas/water supply systems, large-scale communication systems, and traffic/air traffic control systems requiring high reliability
- (4) Facilities that are to comply with regulations of governmental/public agencies or specific industries
- (5) Machinery or equipment that may affect human lives, human bodies or properties
- (6) Other machinery or equipment equivalent to those set forth in items (1) to (5) above which require high reliability and safety

4. Precautions against long-term use

Use of Azbil Corporation's products, including switches, which contain electronic components, over a prolonged period may degrade insulation or increase contact-resistance and may result in heat generation or any other similar problem causing such product or switch to develop safety hazards such as smoking, ignition, and electrification. Although acceleration of the above situation varies depending on the conditions or environment of use of the products, you are required not to use any Azbil Corporation's products for a period exceeding ten (10) years unless otherwise stated in specifications or instruction manuals.

5. Recommendation for renewal

Mechanical components, such as relays and switches, used for Azbil Corporation's products will reach the end of their life due to wear by repetitious open/close operations.

In addition, electronic components such as electrolytic capacitors will reach the end of their life due to aged deterioration based on the conditions or environment in which such electronic components are used. Although acceleration of the above situation varies depending on the conditions or environment of use, the number of open/close operations of relays, etc. as prescribed in specifications or instruction manuals, or depending on the design margin of your machine or equipment, you are required to renew any Azbil Corporation's products every 5 to 10 years unless otherwise specified in specifications or instruction manuals. System products, field instruments (sensors such as pressure/flow/level sensors, regulating valves, etc.) will reach the end of their life due to aged deterioration of parts. For those parts that will reach the end of their life due to aged deterioration, recommended replacement cycles are prescribed. You are required to replace parts based on such recommended replacement cycles.

6. Other precautions

Prior to your use of Azbil Corporation's products, you are required to understand and comply with specifications (e.g., conditions and environment of use), precautions, warnings/cautions/notices as set forth in the technical documents prepared for individual Azbil Corporation's products, such as catalogs, specifications, and instruction manuals to ensure the quality, reliability, and safety of those products.

7. Changes to specifications

Please note that the descriptions contained in any documents provided by azbil are subject to change without notice for improvement or for any other reason. For inquires or information on specifications as you may need to check, please contact our branch offices or sales offices, or your local sales agents.

8. Discontinuance of the supply of products/parts

Please note that the production of any Azbil Corporation's product may be discontinued without notice. After manufacturing is discontinued, we may not be able to provide replacement products even within the warranty period.

For repairable products, we will, in principle, undertake repairs for five (5) years after the discontinuance of those products. In some cases, however, we cannot undertake such repairs for reasons, such as the absence of repair parts. For system products, field instruments, we may not be able to undertake parts replacement for similar reasons.

9. Scope of services

Prices of Azbil Corporation's products do not include any charges for services such as engineer dispatch service. Accordingly, a separate fee will be charged in any of the following cases:

- (1) Installation, adjustment, guidance, and attendance at a test run
- (2) Maintenance, inspection, adjustment, and repair
- (3) Technical guidance and technical education
- (4) Special test or special inspection of a product under the conditions specified by you

Please note that we cannot provide any services as set forth above in a nuclear energy controlled area (radiation controlled area) or at a place where the level of exposure to radiation is equivalent to that in a nuclear energy controlled area.

Document Number:	CM2-RCX100-2001
Document Name:	Admass Coriolis Mass Flowmeter Model RC111C converter RC111F/111U Detector User's Manual
Date:	1st edition: May, 2009 3rd edition: Nov. 2019
Issued/Edited by:	Azbil Corporation

Azbil Corporation