

**User's Manual for Gas/Vapor
Explosion-Proof Increased-Safety
Limit Switches with "Ex d e IIC T6"
IEC Protection for Outdoor Use:
1LX7___-J___ Increased-Safety
Conduit Type Limit Switches and
1LX7___-A1___/1LX7___-R___
Increased-Safety Packing-Type Limit
Switches
(TIIS)**

**Thank you for purchasing an Azbil
Corporation product.**

**This manual contains information for
ensuring the correct use of this prod-
uct. It also provides necessary informa-
tion for installation, maintenance, and
troubleshooting.**

**This manual should be read by those who
design and maintain equipment that uses
this product. Be sure to keep this manual
nearby for handy reference.**

Azbil Corporation

NOTICE

Be sure that the user receives this manual before the product is used.



Copying or duplicating this user's manual in part or in whole is forbidden. The information and specifications in this manual are subject to change without notice.

Considerable effort has been made to ensure that this manual is free from inaccuracies and omissions. If you should find an error or omission, please contact the azbil Group.

In no event is Azbil Corporation liable to anyone for any indirect, special or consequential damages as a result of using this product.

Conventions Used in This Manual

- The safety precautions explained in the following section aim to prevent injury to the operator and others, and to prevent property damage.

 WARNING	Warnings are indicated when mishandling this product might result in death or serious injury.
 CAUTION	Cautions are indicated when mishandling this product might result in minor injury to the user, or physical damage to the product.

- In describing the product, this manual uses the icons and conventions listed below.

 Use caution when handling the product.

 The indicated action is prohibited.

 Be sure to follow the indicated instructions.

 **Handling Precautions:**

Handling Precautions indicate items that the user should pay attention to when handling the 1LX7.

 **Note:** Notes indicate information that might benefit the user.

(1), (2), (3): Numbers within parentheses indicate steps in a procedure or parts of an explanation.

 This indicates the item or page that the user is requested to refer to.

Safety Precautions

WARNING



Be sure to use this limit switch within the ranges specified on page 1 for certified explosion-protected electrical equipment. Failure to do so may cause a serious accident.



To maintain explosion-proof performance, do not disassemble the limit switch, except for removing the cover when wiring, or changing the direction of the lever or head. Otherwise it will not satisfy explosion-proof specifications.

CAUTION



The environmental conditions for the safe use of this limit switch in hazardous atmospheres are described in the product specification sheet. Use this limit switch within the allowable ranges for each characteristic as stated in the specifications.



Check the limit switch periodically to make sure that it is operating normally.







If the cover or exterior of the limit switch has some abnormality (dent, large crack or tiny cracks, etc.) replace the switch immediately. Failure to do so may result in an ineffective seal or loss of explosion-proof performance.



Wiring should comply with "Recommended Practice for Explosion-Protected Electrical Installations in General Industries."

Contents

Conventions Used in This Manual Safety Precautions

Chapter 1. OVERVIEW	1
■ Features	1
■ Applicable laws and standards	1
Chapter 2. NAMES OF PARTS	2
■ Appearance and structure of the limit switch	2
■ Model selection table	2
 Chapter 3. INSTALLATION AND ADJUSTMENT	4
■ Installation	4
■ How to change the lever orientation	6
 ■ How to change the head orientation	7
 Chapter 4. WIRING	8
Chapter 5. ADJUSTMENT	11
■ Points to check before beginning operation	11
■ Adjustment	11
 Chapter 6. MAINTENANCE AND INSPECTION	12
■ Check points for maintenance	13
Chapter 7. SPECIFICATIONS	14

 This symbol indicates the presence of safety instructions.

Memo

Chapter 1. OVERVIEW

■ Features

- This Increased-safety explosion-proof limit switch incorporates an internal flameproof switch.
- Conforms to Japanese explosion-proof standards.
- The internal switch is the two-circuit double-break type.
- Can be used in hydrogen atmospheres.
- IP67 seal allows outdoor use.

■ Applicable laws and standards

WARNING



Be sure to use this limit switch within the ranges specified below for certified explosion-protected electrical equipment. Failure to do so may cause a serious accident.

1. This limit switch is certified as explosion-protected electrical equipment by the Technology Institution of Industrial Safety (TIIS) in accordance with “Recommended Practice for Explosion-Protected Electrical Installations in General Industries” (2008 guidelines, which conform to international standards).
2. Explosion-proof structure d e (d: flameproof enclosure, e: increased-safety)
3. Gas group and temperature class IIC T6
4. Hazardous area classification Gas atmospheres in hazardous Zones 1 and 2
5. Operating temperature -10 to +60 °C
6. Operating humidity 45 to 85 %RH
7. Storage temperature -10 to +60 °C (standard type)
 -10 to +100 °C (H type)
 -40 to +60 °C (L type)
 -10 to +60 °C (if stored using protective plug(s))
8. Storage humidity range 98 %RH max. (if stored using protective plug(s))
9. Protective structure IP54/IP67
10. Example of explosive gas classification

“Recommended Practice for Explosion-Protected Electrical Installations in General Industries” (2006, for gases and vapors)

Temperature class	T1	T2	T3	T4	T5	T6	
Explosive gas class	Over 450 °C	Over 300 to 450 °C	Over 200 to 300 °C	Over 135 to 200 °C	Over 100 to 135 °C	Over 85 to 100 °C	
Explosion-protected electrical equipment group	II	IIA	Acetone Ammonia Ethyl acetate Benzene Carbon monoxide Methane Methanol Propane Toluene	Ethanol Vinyl chloride Butyl acetate Ethylbenzene Dimethylamine Propylene Propan-1-ol Butane Methyl methacrylate	Octane Hexane Cyclohexane Butyl chloride Pentane 1-Octanol Gasoline Kerosene Naphtha	Acetaldehyde Trimethylamine	Ethyl nitrite
		IIB	Acrylonitrile Hydrogen cyanide Cyclopropane Coke oven gas	Ethyl acrylate Ethylene Ethylene oxide 1,3-butadiene	Acrylic aldehyde Crotonaldehyde Dimethyl ether Tetrahydrofuran	Ethyl methyl ether Diethyl ether Dibutyl ether Tetrafluoroethylene	
		IIC	Hydrogen	Acetylene			Carbon disulfide

Note: Switches classified as IIC T6 can be used with a gas or vapor listed inside the bold lines.

Chapter 2. NAMES OF PARTS

■ Appearance and structure of the limit switch

External force applied to the limit switch is transferred as follows: lever → shaft → plunger → internal switch, which opens or closes the electrical circuit.

The limit switch lever rotates both clockwise and counter-clockwise.

The structure and names of parts are shown below.

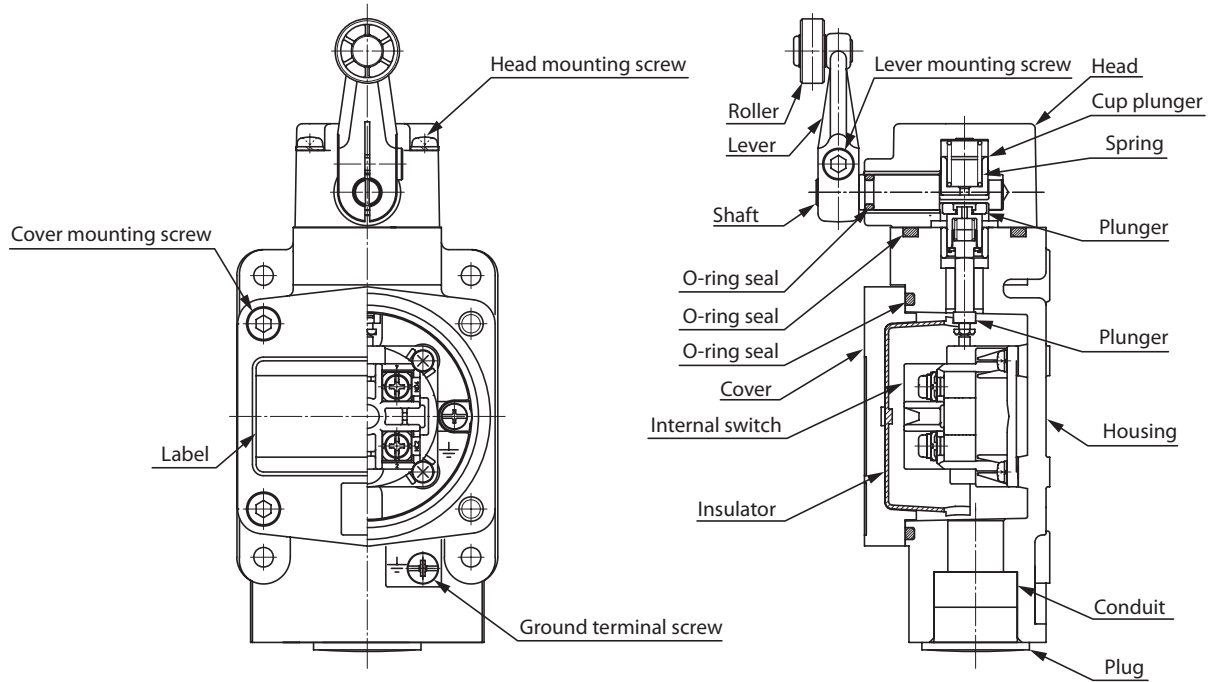

1LX7001-R

■ Model selection table

1LX700 -

Basic model No.	Actuator type	Conduit	Contact material	Environment	Material	Specifications
1LX700						—
	1					Standard roller lever
	2					No lever
	3					Adjustable roller lever
		J				G1/2 straight thread (increased-safety conduit type)
		A1				G1/2 straight thread packing-type cable gland (increased-safety packing-type)
		R				Packing-type connector (increased-safety packing-type)
			None			Silver (for standard loads)
			K			Gold-plated (for minute loads)
				None		Standard
				H		For tropical regions*1
				L		For cold regions*1
					None	Standard
					M	Corrosion-resistant*2

Example: 1LX7001-RM

Roller lever: Standard

Conduit: Packing-type connector (increased-safety packing-type)

Contact material: Silver

Environment: Standard

Material: Corrosion-resistant

*1. See ■ Applicable laws and standards (P. 1) for temperature and humidity.

*2. Cannot be selected with A1.

- **Increased-safety conduit type:**
2PA-JEXN16 nipple + SFT-16 sealing fitting made by Shimada Electric Co., Ltd.

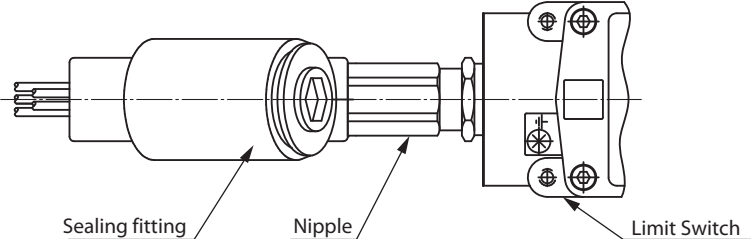

- **Increased-safety packing-type:**
EXPC-16B series packing-type cable gland made by Shimada Electric Co., Ltd.

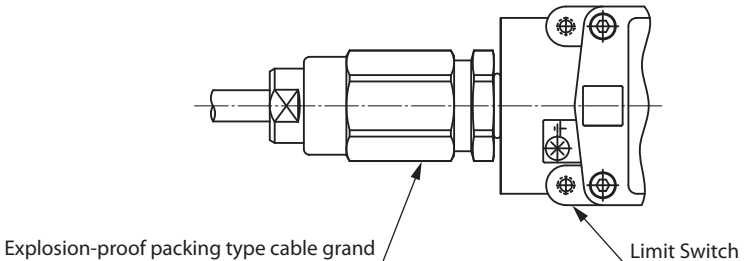



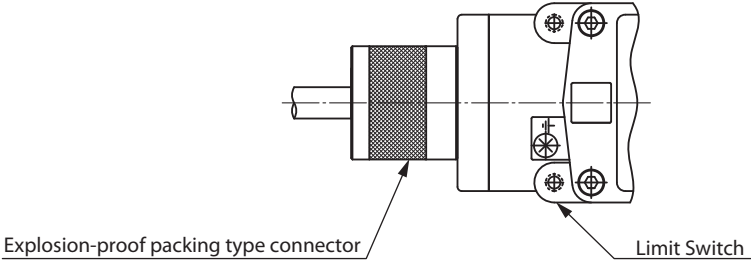







- **Increased-safety packing-type: 2PA-JEX ___ PM series packing-type connector**



Chapter 3. INSTALLATION AND ADJUSTMENT

This section describes how to install the limit switch.

 WARNING
 Never leave or use the limit switch when the cover is off. Doing so may cause an explosion resulting in serious harm.

 CAUTION
 Do not remove the cover or the plug from the limit switch until you are ready to do the wiring. If dust or liquid enters the switch, poor operation, poor electrical contact, or insulation failure may result.
 After wiring is complete, do not leave the limit switch with its cover off. If dust or liquid enters the switch, poor operation, poor electrical contact, or insulation failure may result.
 Before using for the first time, keep the whole limit switch protected with a dustproof and waterproof sheet. Substances like cement or paint stuck to the switch may cause the lever to malfunction.
 Do not leave the limit switch in an atmosphere containing gases that can adversely affect the contacts and/or other materials (H ₂ S, SO _x , etc.). Exposure to such gases can cause contact failure.
 Do not allow the limit switch seal to come into contact with solvents (benzene, kerosene, alcohol, etc.) that may adversely affect them. Contact may lead to poor functioning or insulation failure.
 Do not stand on the limit switch, place heavy objects on it, or strike it. Never apply a force 5 times greater than the operating force (O.F.) to the switch lever. Failure to observe these precautions may result in faulty operation.
 Before using a sealing agent, locking agent, etc., on the conduit joint, make sure that it will not generate fumes that will damage the contacts.
 Make use of heat insulating material, a shielding plate, etc., in mounting the limit switch so that its temperature will not exceed the working temperature range as a result of radiant heat or heat conduction.
 Take appropriate protective countermeasures if the limit switch is installed in a location subject to continuous vibration or impact.

■ Installation

● Installation

For installation of the limit switch, use a mounting plate whose material, thickness, and shape provide sufficient strength so that the operating force of the limit switch cannot deform the plate. When installing the limit switch, use washers or the like to prevent the mounting screws from coming loose. Tighten the mounting bolts to the tightening torque shown below.

Mounting direction	Screw size	Tightening torque
Mounting by screwing from the front	M5 hexagon socket bolts	5 to 6 N·m
Mounting by screwing from the back	M6 hexagon socket bolts	5 to 6 N·m

● Installing the lever

Tighten the lever mounting bolt to the tightening torque shown below.

Screw size	Tightening torque
M5 hexagon socket bolts	4 to 5.2 N·m

● **Sealing fitting (for 1LX7 ___ -J ___ increased-safety conduit type limit switch)**

Use the dedicated nipple and sealing fitting.

! **Handling Precautions**

- Specifications sheet, AD17024E

● **Packing-type cable gland (for 1LX7 ___ -A1 ___ increased-safety packing-type limit switch)**

Choose a packing-type cable gland from the EXPC-16B series made by Shimada Electric Co., Ltd., making sure that is the correct size for the outer diameter of the cable.

! **Handling Precautions**

- If a packing-type cable gland that does not match the outer diameter of the cable is used, poor explosion-proof performance could result.

➡ Specifications sheet, AD18142E

● **Packing-type connector (for 1LX7 ___ -R ___ increased-safety packing-type limit switch)**

Choose a packing-type connector from the 2PA-JEX ___ PM series made by Azbil Corporation, making sure that is the correct size for the outer diameter of the cable.

! **Handling Precautions**

- If a packing-type connector that does not match the outer diameter of the cable is used, poor explosion-proof performance could result.

➡ 2PA-JEX ___ PM Series Increased-Safety Packing-Type Connector for LX/VCX Series Limit Switch User's Manual, CP-UM-5717JE.

● **Actuating object velocity and angle**

- Actuating object velocity < 0.5 m/s (slow)

Select the angle (α) of the actuating object to the vertical lever that corresponds to the object's velocity (V) in the table below.

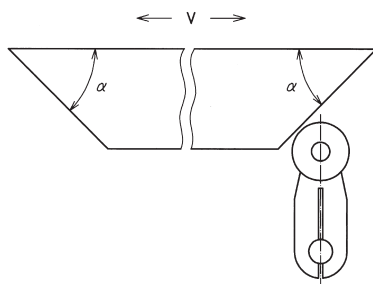

Angle of slow-moving actuating object

Actuating object angle (α)	Actuating object max. velocity (V)
30°	0.40 m/s
45°	0.25 m/s
60°	0.10 m/s
75°	0.07 m/s
90°	0.05 m/s

- Actuating object velocity 0.5 m/s $\leq V \leq 2$ m/s (fast)

Based on the velocity (V) of the actuating object, select its angle (α) and the lever angle (θ) from the table below.

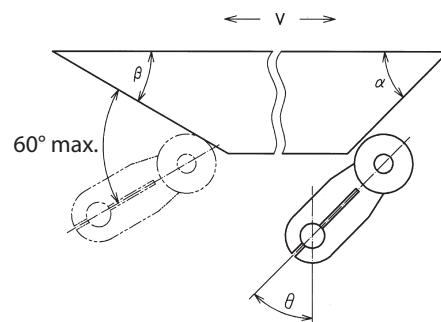

If the rear angle (β) of the actuating object is set to 15–30°, a double action of the lever can be prevented.

Angle of fast-moving actuating object and of lever

Actuating object angle (α)	Lever angle (θ)	Actuating object max. velocity (V)
45°	45°	0.50 m/s
40°	50°	0.60 m/s
30 to 35°	55 to 60°	1.30 m/s
15 to 25°	65 to 75°	2.00 m/s

The allowable operating speed of the product is specified in the specifications sheet.

● **About the actuating object**

The roughness and hardness of the object's surface significantly affects the operating life of the switch. The following specifications are recommended.

Roughness	Hardness
Approx. Ra 6.3	Approx. HV 450

 **Note**

- If grease is applied to the sliding parts of the roller, actuating object, etc., they will move more smoothly.

 **Handling Precautions**

- The actuating object should not touch anything other than the roller.

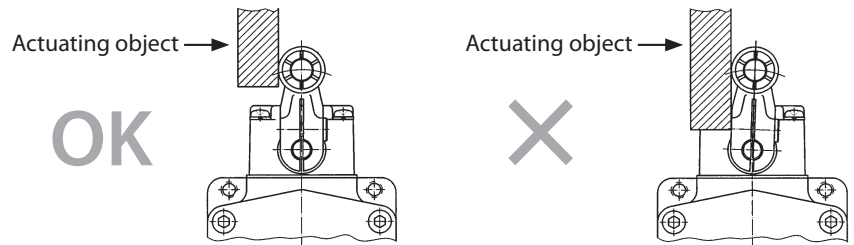

The object makes contact not only with the roller but also with other parts.

- The full width of the roller should make contact with the actuating object.

● **Overtravel and force**

To ensure reliable operation, set overtravel (O.T.) between 1/3 to 2/3 of the overtravel stated in the specifications.

 **Handling Precautions**

- Do not apply excessive force (5 times the O.F. or more) to the lever beyond the operating limit position. Doing so may cause faulty operation.

■ **How to change the lever orientation**

● **Procedure**

- (1) Loosen the lever mounting bolt.
- (2) Turn the lever over and reattach it.
- (3) Tighten the lever mounting bolt according to the table below.

Screw size	Tightening torque
M5 hexagon socket bolts	4 to 5.2 N·m

 **Handling Precautions**

- Do not tighten beyond the specified torque. Overtightening may damage screw threads.

■ How to change the head orientation

● Procedure

- (1) Remove the four head mounting screws.

⚠ Handling Precautions

- The O-ring attached to this unit may come off when the head assembly is removed. Be sure to put it back in its original position.
- (2) Change the head orientation as desired for the application. As viewed from the front, the head can rotate 90° or 180° clockwise or counterclockwise.
 - (3) Tighten the head mounting screws according to the table below.

Screw size	Tightening torque
M4 (pan head screw with spring washer)	1.3 to 1.7 N·m

Chapter 4. WIRING

This section describes wiring of the limit switch.

⚠ WARNING



Before wiring, turn the equipment power off. Depending on the voltage, failure to do so may result in an electric shock.

⚠ CAUTION



Wiring should comply with “Recommended Practice for Explosion-Protected Electrical Installations in General Industries.”



Securely attach the cover so that it tightly contacts the housing. If the cover is not well tightened, the limit switch will not be effectively sealed.



Be sure to ground the limit switch using either the internal or external ground screw.



Do not use wire with silicone rubber insulation, or adhesive or grease which contains silicone. They can cause contact failure in electrical contacts.



For connection to a conduit with G1/2 pipe thread, screw in to a depth of at least 5 threads, and secure with a lock nut. If waterproofing is required, apply sealant to the screw threads. For explosion-proofing, be sure to use a sealing fitting to connect the conduit to the switch, and apply sealing compound. For waterproof applications, use liquid gasket or other sealant on the conduit threads.



Use wires or cables with a heat resistance to temperatures of 70 °C or more.

⚠ Handling Precautions

- When wiring the terminal block, use wires whose nominal cross-sectional area is 0.5–1.5 mm² (20–16 AWG) or cables whose nominal cross-sectional area is 0.5–2.5 mm² (20–14 AWG) together with M4 crimp terminals with insulating sleeves (made by J.S.T. Mfg. Co., Ltd., or equivalent).
- The figure below shows the size of the crimp terminal.

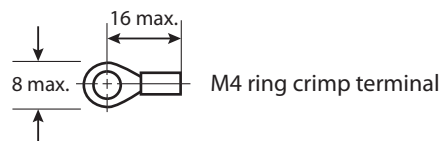

- Make sure that the crimp terminals and wires do not touch the cover.
- Bend the insulated crimp terminals down. Otherwise, the cover will not close properly.
- Make sure that wires do not touch the plunger. If they do, poor performance could result.
- When installing flexible piping, do not twist the wires inside.

● Removing the cover

Remove the M5 hexagon socket bolts using a 4 mm hexagon wrench.

● Wiring of the limit switch

⚠ CAUTION



To wire the limit switch correctly, refer to the user's manual or the product specification sheet.

- Tighten terminal screws to the torque shown below.

Screw size	Tightening torque
M4 (pan head screw with square washer)	1.3 to 1.7 N·m

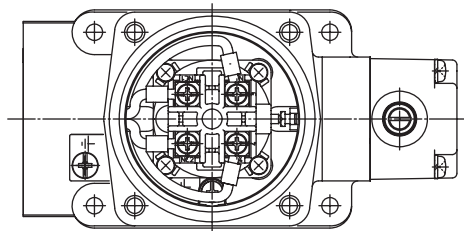

Wire routing

- Pull-out strength of the terminal
After wiring, do not pull the wire or cable with excessive force (≥ 30 N).

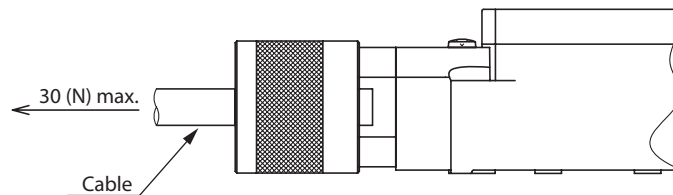

⚠ Handling Precautions

- Do not exceed the values given for pulling force, which is the same for both single wire and two-ply or more stranded wires.

● Attaching the cover

Be sure to attach the cover after wiring is complete.

Tighten the four cover mounting screws evenly in a diagonal pattern.

Tighten the screws to the torque shown below.

Screw size	Tightening torque
M5 (hexagon socket bolt with spring washer)	5 to 6 N·m

⚠ Handling Precautions

- When mounting the cover, make sure that it does not touch electrical wires or terminals, and does not pinch the wiring insulation.
- Do not tighten beyond the specified torque. Overtightening may damage screw threads of the housing.

● Continuity tester

For a continuity check for the limit switch, use a tester whose measuring current is 100 mA or less.

- **Mounting a sealing fitting**

(for 1LX7 ___ -J ___ increased-safety conduit type limit switch)

☞ AD specifications sheet, AD17024E

- **Mounting a packing-type cable gland**

(for 1LX7 ___ -A1 ___ increased-safety packing-type limit switch)

☞ AD specifications sheet, AD18142E

- **Mounting a packing-type connector**

(for 1LX7 ___ -R ___ increased-safety packing-type limit switch)

☞ 2PA-JEX___PM Series Increased-Safety Packing-Type Connector for LX/VCX Series Limit Switch User's Manual, CP-UM-5717JE.

Chapter 5. ADJUSTMENT

■ Points to check before beginning operation

Check the following before using the limit switch.

- (1) Wiring is correctly done.
- (2) Limit switch mounting bolts, lever mounting bolts, and cover mounting hexagon socket bolts are tight.
- (3) Conduit is well sealed using a sealed connector or flexible piping.

■ Adjustment

- (1) To adjust the operating position of the limit switch, change the position of the actuating object or of the limit switch.
- (2) To ensure reliable operation, set overtravel (O.T.) to between 1/3 and 2/3 of the value stated in the specifications.

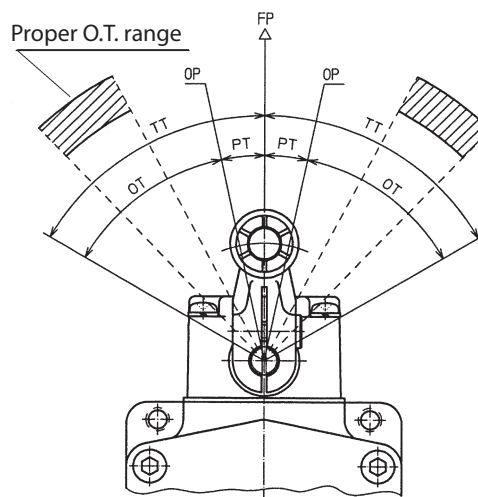

! Handling Precautions



- Do not apply excessive force (5 times the O.F. or more) to the lever beyond the operating limit position. Doing so may result in faulty operation.
- Do not attempt to move the lever beyond the operating limit.
- Adjustment is also possible by changing the mounting position of the lever. However this method cannot be used repeatedly because the knurling on the shaft bites into the lever.

Chapter 6. MAINTENANCE AND INSPECTION

WARNING

-  Be sure to use this limit switch within the ranges specified on page 1 for certified explosion-protected electrical equipment. Failure to do so may cause a serious accident.

CAUTION

-  After inspecting the limit switch, firmly tighten the cover and conduit.
Insufficient tightening because of corrosion, etc., not only results in the loss of sealing and insulating performance, but also nullifies the switch's explosion-proofing.
-  Except for the lever, individual parts of this limit switch cannot be replaced. Replace the entire switch.
-  To ensure safe use the limit switch must be inspected periodically.
Adjust the frequency of inspection depending on the service conditions.

■ Check points for maintenance

The table below shows check points for maintenance of the limit switch. Because the service life of this switch is five years, in general the switch should be replaced every five years. However, the service life varies depending on the application environment.

● Equipment required for inspection

- Screwdriver
- Insulation resistance tester
- Adjustable wrench
- Continuity tester
- Hex wrench (Allen wrench)

#	Area	Items	Inspection Method	Corrective Action	Frequency
1	Roller lever	<ul style="list-style-type: none"> • Operating position • Slippage from set position • Loose mounting bolts • Roller rotation 	<ul style="list-style-type: none"> • Check for loose lever mounting bolts, poor roller rotation, damage, etc. 	<ul style="list-style-type: none"> • Tighten mounting bolts if they are loose. (See chap. 3 (P. 4) for tightening torque.) • In other cases, replace the limit switch. 	Basically every 6 months, but whenever there is an opportunity
2	Head	<ul style="list-style-type: none"> • Loose head mounting screws • External damage 	<ul style="list-style-type: none"> • Check visually, etc., for loose head mounting screws. • Check for damage to the head. 	<ul style="list-style-type: none"> • Tighten mounting screws if they are loose. (See chap. 3 (P. 4) for tightening torque.) • In other cases, replace the limit switch. 	
3	Cover	<ul style="list-style-type: none"> • Loose cover mounting screws • External damage 	<ul style="list-style-type: none"> • Check visually, etc., for loose cover mounting screws. • Check for damage to the cover. 	<ul style="list-style-type: none"> • Tighten mounting screws if they are loose. (See chap. 4 (P. 9) for tightening torque.) • In other cases, replace the limit switch. 	
4	Housing	<ul style="list-style-type: none"> • External damage 	<ul style="list-style-type: none"> • Visually check for damage. 	<ul style="list-style-type: none"> • Replace the limit switch. 	Every 2 years
5	Internal switch	<ul style="list-style-type: none"> • Electrical continuity 	<ul style="list-style-type: none"> • Check the electric continuity of all terminals using a continuity tester. 	<ul style="list-style-type: none"> • Tighten terminal screws if they are loose. (See chap. 4 (P. 9) for tightening torque.) 	Basically every 6 months, but whenever there is an opportunity
		<ul style="list-style-type: none"> • Isolation 	<ul style="list-style-type: none"> • Check all terminals using an insulation resistance tester. 		
		<ul style="list-style-type: none"> • Loose screws • Corrosion 	<ul style="list-style-type: none"> • Check for loose terminal screws, damage, rust, etc. 		
6	Operation check	<ul style="list-style-type: none"> • Operation check 	<ul style="list-style-type: none"> • Check the overtravel. 	<ul style="list-style-type: none"> • Readjust the overtravel. 	
			<ul style="list-style-type: none"> • Check by hand that the roller lever moves smoothly. 	<ul style="list-style-type: none"> • Replace the limit switch. 	
7	Nipple and sealing fitting	<ul style="list-style-type: none"> • Loose nipple or sealing fitting 	<ul style="list-style-type: none"> • Check nipple and sealing fitting for looseness. 	<ul style="list-style-type: none"> • Tighten nipple and/or sealing fitting. 	
8	Packing-type cable gland	<ul style="list-style-type: none"> • Loose cable gland 	<ul style="list-style-type: none"> • Check for cable gland looseness. 		
		<ul style="list-style-type: none"> • Loose cable 	<ul style="list-style-type: none"> • Check for cable looseness. 		
9	Packing-type connector	<ul style="list-style-type: none"> • Loose connector 	<ul style="list-style-type: none"> • Check for connector looseness. 		
		<ul style="list-style-type: none"> • Loose cable 	<ul style="list-style-type: none"> • Check for cable looseness. 		

Note: The internal parts of this limit switch cannot be replaced. Replace the entire limit switch.

Chapter 7. SPECIFICATIONS

For detailed limit switch specifications, see the specifications sheet. The relevant specifications sheet numbers are shown below. To acquire them, contact the azbil Group.

Model No.	Specifications sheet No.
1LX700_ - _ _ _ _	AD18142E
2PA-JEX_ _ _ _ PM	AD17216E
2PA-JEXN_ _	AD17024E

Terms and Conditions

We would like to express our appreciation for your purchase and use of Azbil Corporation's products. You are required to acknowledge and agree upon the following terms and conditions for your purchase of Azbil Corporation's products (system products, field instruments, control valves, and control products), unless otherwise stated in any separate document, including, without limitation, estimation sheets, written agreements, catalogs, specifications and instruction manuals.

1. Warranty period and warranty scope

1.1 Warranty period

Azbil Corporation's products shall be warranted for one (1) year from the date of your purchase of the said products or the delivery of the said products to a place designated by you.

1.2 Warranty scope

In the event that Azbil Corporation's product has any failure attributable to azbil during the aforementioned warranty period, Azbil Corporation shall, without charge, deliver a replacement for the said product to the place where you purchased, or repair the said product and deliver it to the aforementioned place.

Notwithstanding the foregoing, any failure falling under one of the following shall not be covered under this warranty:

- (1) Failure caused by your improper use of azbil product (noncompliance with conditions, environment of use, precautions, etc. set forth in catalogs, specifications, instruction manuals, etc.);
- (2) Failure caused for other reasons than Azbil Corporation's product;
- (3) Failure caused by any modification or repair made by any person other than Azbil Corporation or Azbil Corporation's subcontractors;
- (4) Failure caused by your use of Azbil Corporation's product in a manner not conforming to the intended usage of that product;
- (5) Failure that the state-of-the-art at the time of Azbil Corporation's shipment did not allow Azbil Corporation to predict; or
- (6) Failure that arose from any reason not attributable to Azbil Corporation, including, without limitation, acts of God, disasters, and actions taken by a third party.

Please note that the term "warranty" as used herein refers to equipment-only-warranty, and Azbil Corporation shall not be liable for any damages, including direct, indirect, special, incidental or consequential damages in connection with or arising out of Azbil Corporation's products.

2. Ascertainment of suitability

You are required to ascertain the suitability of Azbil Corporation's product in case of your use of the same with your machinery, equipment, etc. (hereinafter referred to as "Equipment") on your own responsibility, taking the following matters into consideration:

- (1) Regulations and standards or laws that your Equipment is to comply with.
- (2) Examples of application described in any documents provided by Azbil Corporation are for your reference purpose only, and you are required to check the functions and safety of your Equipment prior to your use.
- (3) Measures to be taken to secure the required level of the reliability and safety of your Equipment in your use

Although azbil is constantly making efforts to improve the quality and reliability of Azbil Corporation's products, there exists a possibility that parts and machinery may break down.

You are required to provide your Equipment with safety design such as fool-proof design, *1 and fail-safe design*2 (anti-flame propagation design, etc.), whereby preventing any occurrence of physical injuries, fires, significant damage, and so forth. Furthermore, fault avoidance,*3 fault tolerance,*4 or the like should be incorporated so that the said Equipment can satisfy the level of reliability and safety required for your use.

*1. A design that is safe even if the user makes an error.

*2. A design that is safe even if the device fails.

*3. Avoidance of device failure by using highly reliable components, etc.

*4. The use of redundancy.

3. Precautions and restrictions on application

Azbil Corporation's products other than those explicitly specified as applicable (e.g. azbil Limit Switch For Nuclear Energy) shall not be used in a nuclear energy controlled area (radiation controlled area).

Any Azbil Corporation's products shall not be used for/with medical equipment.

The products are for industrial use. Do not allow general consumers to install or use any Azbil Corporation's product.

However, azbil products can be incorporated into products used by general consumers. If you intend to use a product for that purpose, please contact one of our sales representatives.

In addition,

you are required to conduct a consultation with our sales representative and understand detail specifications, cautions for operation, and so forth by reference to catalogs, specifications, instruction manual, etc. in case that you intend to use azbil product for any purposes specified in (1) through (6) below.

Moreover, you are required to provide your Equipment with fool-proof design, fail-safe design, anti-flame propagation design, fault avoidance, fault tolerance, and other kinds of protection/safety circuit design on your own responsibility to ensure reliability and safety, whereby preventing problems caused by failure or nonconformity.

- (1) For use under such conditions or in such environments as not stated in technical documents, including catalogs, specification, and instruction manuals
- (2) For use of specific purposes, such as:
 - * Nuclear energy/radiation related facilities
[For use outside nuclear energy controlled areas] [For use of Azbil Corporation's Limit Switch For Nuclear Energy]
 - * Machinery or equipment for space/sea bottom
 - * Transportation equipment
[Railway, aircraft, vessels, vehicle equipment, etc.]
 - * Antidisaster/crime-prevention equipment

- * Burning appliances
 - * Electrothermal equipment
 - * Amusement facilities
 - * Facilities/applications associated directly with billing
- (3) Supply systems such as electricity/gas/water supply systems, large-scale communication systems, and traffic/air traffic control systems requiring high reliability
 - (4) Facilities that are to comply with regulations of governmental/public agencies or specific industries
 - (5) Machinery or equipment that may affect human lives, human bodies or properties
 - (6) Other machinery or equipment equivalent to those set forth in items (1) to (5) above which require high reliability and safety
4. Precautions against long-term use

Use of Azbil Corporation's products, including switches, which contain electronic components, over a prolonged period may degrade insulation or increase contact-resistance and may result in heat generation or any other similar problem causing such product or switch to develop safety hazards such as smoking, ignition, and electrification. Although acceleration of the above situation varies depending on the conditions or environment of use of the products, you are required not to use any Azbil Corporation's products for a period exceeding ten (10) years unless otherwise stated in specifications or instruction manuals.
 5. Recommendation for renewal

Mechanical components, such as relays and switches, used for Azbil Corporation's products will reach the end of their life due to wear by repetitious open/close operations. In addition, electronic components such as electrolytic capacitors will reach the end of their life due to aged deterioration based on the conditions or environment in which such electronic components are used. Although acceleration of the above situation varies depending on the conditions or environment of use, the number of open/close operations of relays, etc. as prescribed in specifications or instruction manuals, or depending on the design margin of your machine or equipment, you are required to renew any Azbil Corporation's products every 5 to 10 years unless otherwise specified in specifications or instruction manuals. System products, field instruments (sensors such as pressure/flow/level sensors, regulating valves, etc.) will reach the end of their life due to aged deterioration of parts. For those parts that will reach the end of their life due to aged deterioration, recommended replacement cycles are prescribed. You are required to replace parts based on such recommended replacement cycles.
 6. Other precautions

Prior to your use of Azbil Corporation's products, you are required to understand and comply with specifications (e.g., conditions and environment of use), precautions, warnings/cautions/notices as set forth in the technical documents prepared for individual Azbil Corporation's products, such as catalogs, specifications, and instruction manuals to ensure the quality, reliability, and safety of those products.
 7. Changes to specifications

Please note that the descriptions contained in any documents provided by azbil are subject to change without notice for improvement or for any other reason. For inquires or information on specifications as you may need to check, please contact our branch offices or sales offices, or your local sales agents.
 8. Discontinuance of the supply of products/parts

Please note that the production of any Azbil Corporation's product may be discontinued without notice. For repairable products, we will, in principle, undertake repairs for five (5) years after the discontinuance of those products. In some cases, however, we cannot undertake such repairs for reasons, such as the absence of repair parts. For system products, field instruments, we may not be able to undertake parts replacement for similar reasons.
 9. Scope of services

Prices of Azbil Corporation's products do not include any charges for services such as engineer dispatch service. Accordingly, a separate fee will be charged in any of the following cases:

 - (1) Installation, adjustment, guidance, and attendance at a test run
 - (2) Maintenance, inspection, adjustment, and repair
 - (3) Technical guidance and technical education
 - (4) Special test or special inspection of a product under the conditions specified by you

Please note that we cannot provide any services as set forth above in a nuclear energy controlled area (radiation controlled area) or at a place where the level of exposure to radiation is equivalent to that in a nuclear energy controlled area.



Specifications are subject to change without notice. (09)

Azbil Corporation
Advanced Automation Company

1-12-2 Kawana, Fujisawa
Kanagawa 251-8522 Japan

URL: <http://www.azbil.com>

1st edition: June 2012 (V)
3rd edition: Mar. 2017 (F)