

Micro Flow Rate Liquid Flow Meter

Model F7M

User's Manual

Thank you for purchasing an Azbil Corporation product.

This manual contains information for ensuring the correct use of this product. It also provides necessary information for installation, maintenance, and troubleshooting.

This manual should be read by those who design and maintain equipment that uses this product. Be sure to keep this manual nearby for handy reference.

Azbil Corporation

NOTICE

Be sure that the user receives this manual before the product is used.



Copying or duplicating this user's manual in part or in whole is forbidden. The information and specifications in this manual are subject to change without notice.

Considerable effort has been made to ensure that this manual is free from inaccuracies and omissions. If you should find an error or omission, please contact the azbil Group.

In no event is Azbil Corporation liable to anyone for any indirect, special or consequential damages as a result of using this product.

Conventions Used in This Manual

- The safety precautions explained in the following section aim to prevent injury to the operator and others, and to prevent property damage.

	WARNING	Warnings are indicated when mishandling this product might result in death or serious injury.
	CAUTION	Cautions are indicated when mishandling this product might result in minor injury to the user, or only physical damage to the product.

- In describing the product, this manual uses the icons and conventions listed below.



Use caution when handling the product.



The indicated action is prohibited.



Always follow the indicated instructions.



Handling Precautions:

Handling Precautions indicate items that the user should pay attention to when handling the product.



Note:

Notes indicate information that might benefit the user.



This indicates the item or page that the user is requested to refer to.

(1) (2) (3):

Numbers within parentheses indicate steps in a sequence or parts of an explanation.

Safety Precautions

WARNING



Do not apply pressure or temperature that is outside the range stated in the specifications of this device. Do not drop this device or subject it to vibration or impact that exceeds the conditions for use. Doing so may damage the fused quartz glass tube (used as the flow path in this device) and its seal, causing leakage inside and outside of the device, fire, or failure of this device and connected devices. (☞ Precautions (P. 4))

CAUTION



If damage could result from a problem with this device, implement an appropriate redundant design.



Take appropriate measures so that no foreign matter is included with the fluid. If rust, oil mist, or other foreign matter from the pipes enters and adheres to this device, a measurement or control error may occur, or this device may be damaged. If there is a possibility of foreign matter entering this device, install a filter upstream of this device or take other appropriate measures. Be sure to inspect and replace the filter at regular intervals.



Install this device in a place without vibration. Otherwise, measurements will be incorrect and a device malfunction or failure may result.



During or after work on the piping, do not apply a load to the product or the connections that exceeds the range stated in the specifications. Doing so may damage the fittings or the fused quartz glass tube inside the device, resulting in leakage.



If there is a possibility that a load that exceeds the range stated in the specifications has been applied, check for leakage before use.



The power supply circuit and I/O circuit are not isolated. Therefore, ensure that the power supply is isolated from the power supply of external devices. If this device and external devices share a common power supply, faulty operation or device failure may result.



If there is a risk of a power surge caused by lightning, use a surge absorber (surge protector). Otherwise there is a danger of fire or device failure.



Make sure that the wiring is correct before turning the power on. Incorrect wiring will cause damage and device failure.



If any problem occurs during operation, shut off the power immediately and stop using the device.



Do not press the switches on the device with excessive force or with a sharp object. Doing so may impair the protective functions of this device.



Make sure that there is no fluid or pressure inside the piping before removing this device. There is a danger that residual fluid in the piping may spew out.

The Role of This Manual

A total of three different manuals are available for model F7M Micro Flow Rate Liquid Flow Meter. Read them as necessary for your specific requirements. If a manual you require is not available, contact the azbil Group or its dealer.

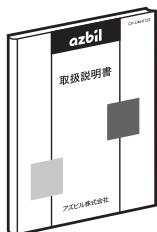

Micro Flow Rate Liquid Flow Meter Model F7M User's Manual

Manual No. CP-SP-1421E

This manual.

This manual describes the hardware and all functions of the F7M. Personnel in charge of the design, manufacture, operation, or maintenance of equipment that incorporates this device should read this manual thoroughly. This manual covers installation, connections for wiring, all functions and settings of this device, operating procedures, troubleshooting, and detailed specifications.

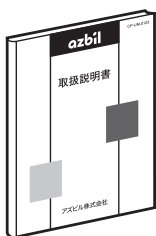

User's Manual for Smart Loader Package Model SLP-F7M for Micro Flow Rate Liquid Flow Meter Model F7M

Manual No. CP-SP-1423E

The user can specify and check parameters of the F7M on a PC using the SLP loader package. Personnel in charge of the design or manufacture of equipment that incorporates this device should read this manual thoroughly. This manual describes the method of connecting this device to a PC and the operation of the loader on the PC.

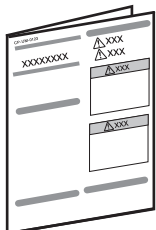

Micro Flow Rate Liquid Flow Meter Model F7M9010/9030/9050 User's Manual

Manual No. CP-UM-5922JE

This manual is supplied with the product.

Personnel in charge of the design or configuration of equipment that incorporates this device and personnel in charge of installation of this device should read this manual thoroughly. The manual covers safety precautions, installation, wiring, and main specifications.

Contents

Conventions Used in This Manual

Safety Precautions

The Role of This Manual

Chapter 1. Overview	1
■ Overview	1
■ Model Selection	1
Chapter 2. Names and Functions of Parts	2
■ Operation panel	2
■ Structure	3
■ Internal structure	3
Chapter 3. Installation and Wiring	4
■ Precautions	4
■ Installation precautions	4
3-1 Installation	5
■ Installation location	5
■ Installation procedure	5
3-2 Wiring	7
■ Waterproof connector	7
■ Wiring example	7
Chapter 4. Startup of the Device	8
■ Startup of the device	8
■ Zero point adjustment	8
Chapter 5. Advanced Operations	10
■ List of Parameters	10
■ Flow rate calculation processing	11
■ Flow rate output correction	11
■ Analog output correction	12
■ Digital input functions	13
■ Digital output functions	14
■ Function setup	15
Chapter 6. Troubleshooting	16
■ Types of abnormal status	16
■ Abnormal status and corrective actions	16
■ Other problems	18
Chapter 7. Specifications	19
■ General specifications	19
■ Parts sold separately	21
■ External dimensions	23
■ Label	24

SAFETY SHEET

Chapter 1. Overview

■ Overview

The model F7M Micro Flow Rate Liquid Flow Meter (hereafter “this device”) uses a thermal flow sensor developed by Azbil Corporation as its sensing element.

■ Model Selection

Basic model No.	Flow rate range				Display function	Flow path material	Piping connection method	Fluid type	Signal type	Connector type	Optional functions			Code	Remarks
											1	2	3		
F7M															Micro flow rate liquid flow meter
	9	0	1	0											Measurable flow rate range: 0.1–10 mL/min
	9	0	3	0											Measurable flow rate range: 0.3–30 mL/min
	9	0	5	0											Measurable flow rate range: 0.5–50 mL/min
					A										No display (equipped with an LED status indicator)
						Q									Fused quartz glass, PFA, PTFE
							1								Fitting for fluororesin tubes P series Super 300 Type Pillar Fitting (made by Nippon Pillar Packing Co., Ltd.). Outer dia. 3 mm, inner dia. 2 mm
							2								Fitting for fluororesin tubes P series Super 300 Type Pillar Fitting (made by Nippon Pillar Packing Co., Ltd.). Outer dia. 1/8 inch, inner dia. 0.086 inch
								0							Water (H ₂ O)
									0						Analog output, digital input, digital output
										1					Waterproof connector
											0				None
												0			None
													0		None
													D		With inspection report
													Y		With inspection report and traceability certificate
														0	Product version

Note: Flow rate ranges are for water (H₂O).

Chapter 2. Names and Functions of Parts

■ Operation panel

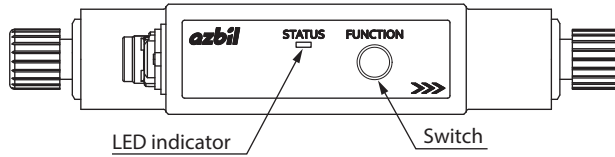

📖 Note

- The switch is used to adjust the zero point of the flow rate. Zero point adjustment is not necessary for water. ➡ Zero point adjustment (p. 8) (for adjustment procedure)

● LED indicator

The LED indicator on the top of this device indicates the following.

- For measurement

Operating state	LED behavior
Operating normally	Lit green
Warning	Blinks green (slowly)
Alarm	Blinks red (slowly)
Error	Lit red
Power shutoff	Off

- For zero point adjustment

Operating state	LED behavior
Zero point adjustment in progress	Blinks green (fast)
Zero point adjustment completed	Blinks green three times
Zero point adjustment initialization completed	Blinks green three times
Zero point adjustment failed	Blinks red three times

- LED blink pattern

LED behavior	Blink pattern
Blinks fast	Turns on and off at 100 ms intervals
Blinks slowly	Turns on and off at 500 ms intervals

● LED transitions

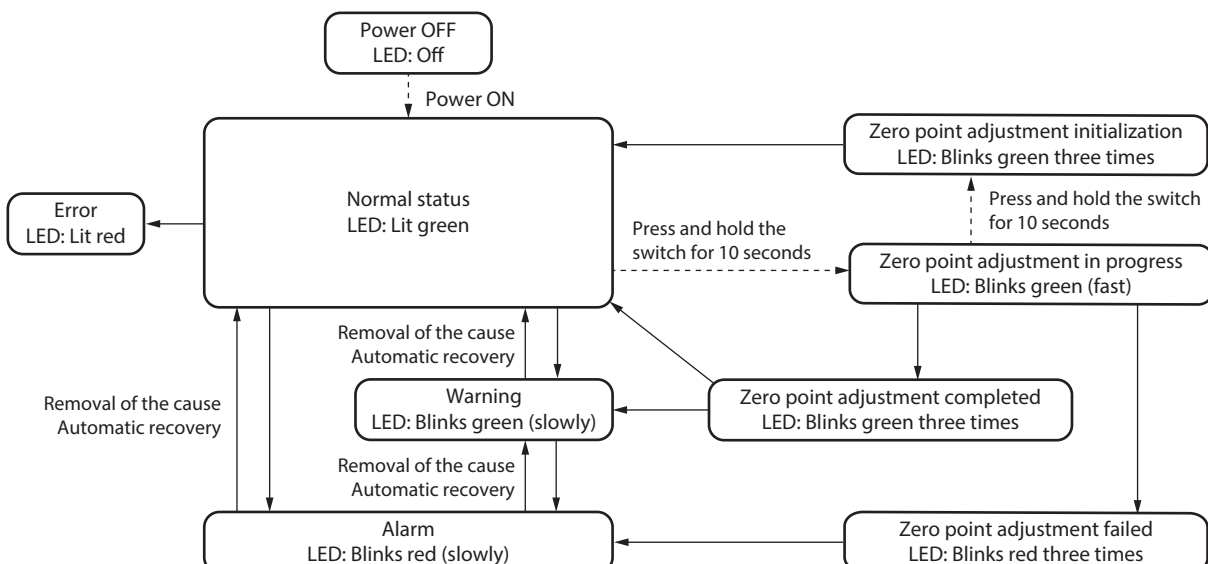

■ Structure

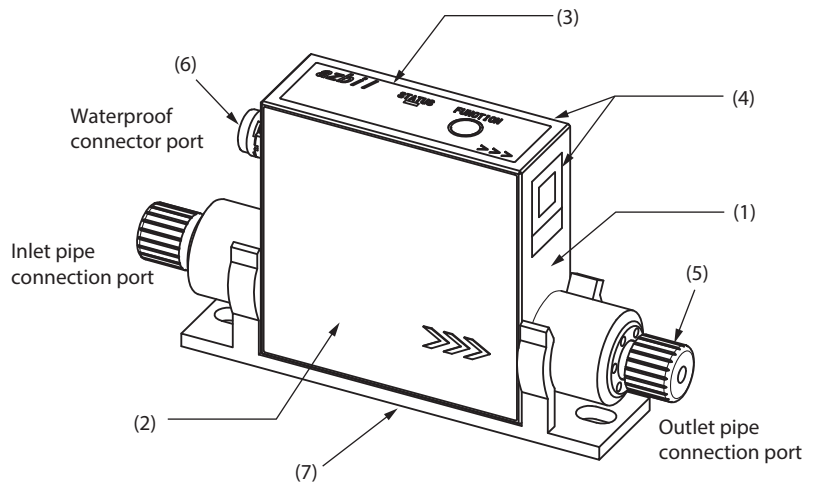

• Main unit materials

No.	Name	Material	Note
(1)	Housing	PPS + glass fiber	An epoxy resin adhesive is used to connect the housing to the cover.
(2)	Cover	PPS + glass fiber	
(3)	Protective sheet	PET film	—
(4)	Label	PET film	—
(5)	Union nut	PFA	This part is included with the product but not attached at delivery.
(6)	Waterproof connector	PPS, PBT, CR rubber	HR30-6R-6P (71), made by Hirose Electric Co., Ltd.
(7)	Mounting bracket	PC	—

■ Internal structure

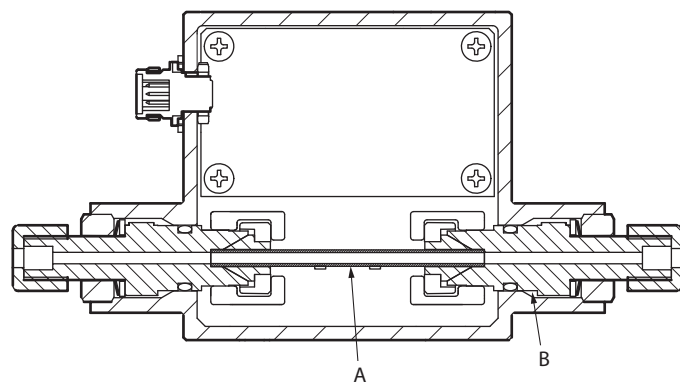

• Wetted material

No.	Name	Material	Note
A	Sensor tube	Fused quartz glass	—
B	Fitting	PFA, PTFE	The material of the included sleeves is PFA.

Chapter 3. Installation and Wiring

■ Precautions

If this device is used under conditions that exceed the conditions of use stated in the specifications (fluid pressure exceeding the stated pressure resistance, high-temperature fluid exceeding the process fluid temperature range, excessive vibration, etc.) or if this device is dropped, the flow path or its seal can be damaged, causing the following phenomena:

- Sensor problems (error output, or output of 0 V only continues)
- Power short-circuit of an external device due to impaired isolation of this device
- Fluid leakage from the housing (if the fluid pressure is high, fluid will spew out from the protective sheet)

If these phenomena occur, shut off the power and fluid to this device immediately and stop using it.

■ Installation precautions

- Install this device in a place without vibration. Otherwise, measurements will be incorrect and device malfunction or failure may result.
- Install the mounting bracket, observing the specified mounting dimensions. Otherwise, the mounting bracket may be damaged.
- Use a tube that fits the description in the specifications for the piping connected to this device.
- Attach the tube in accordance with the Super 300 Type Pillar Fitting P Series Instruction Manual (by Nippon Pillar Packing Co., Ltd.). Tighten the fitting securely by hand.
- During or after piping, do not apply excessive force that deforms the device. Doing so may damage the fittings or the fused quartz glass tube that is used as the flow path.
- If the fluid contains bubbles or pulsations, the flow rate output from the device might be unreliable or there might be measurement errors. Make sure that bubbles or pulsations are not generated in the fluid.
- This device cannot measure the flow rate of fluid that flows in the reverse direction. If the flow direction is reversed, this device outputs a flow rate that is close but not equal to the regular forward flow rate, and it does not indicate an error.
- Check that there is no leakage after the piping work and during operation at regular intervals.

3-1 Installation

■ Installation location

Do not install where exposed to any of the following:

- Temperature and humidity that exceed the specified high/low limits
- Sudden temperature changes that result in condensation
- Corrosive gas or flammable gas atmosphere
- Large amounts of dust, salt, iron powder or other conductive substances in the atmosphere, or water droplets, oil mist, or organic solvents
- Direct sunlight, wind, or rain
- Direct vibration or shock
- Sources of electrical noise
- Strong magnetic or electrical fields

■ Installation procedure

- (1) Install the mounting bracket securely.

! Handling Precautions

- Screws are not included with the product. (Screw hole dia.: 5.6 mm, screw head height: 5 mm max.)

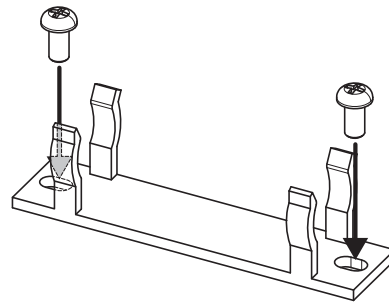

- (2) Mount the main unit on the mounting bracket.

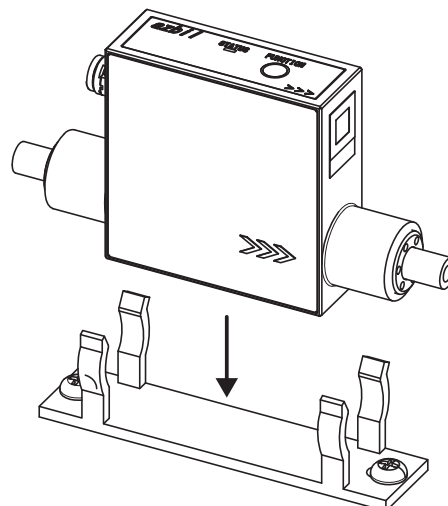

- (3) Attach the upstream and downstream fluoro-resin tubes to the device as instructed below. Cut the tube → Insert the union nut → Insert the sleeve into the tube (a special tool is required)

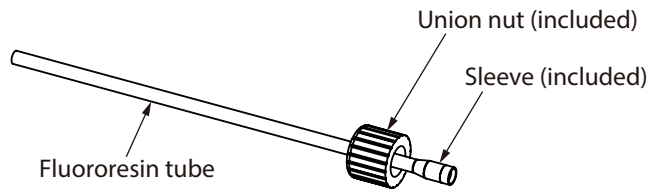

 **Note**

- For detailed instructions on mounting the fluoro-resin tubes, see the Super 300 Type Pillar Fitting P Series Instruction Manual (published by Nippon Pillar Packing Co., Ltd.).

- (4) Attach the fluoro-resin tubes and the I/O cable to the main unit.

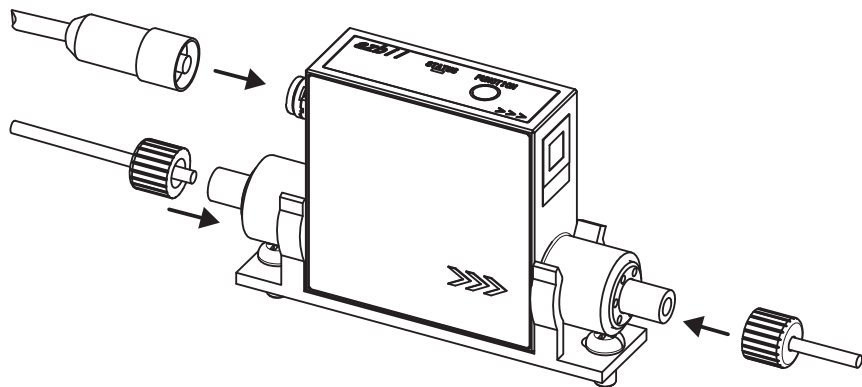

 **Handling Precautions**

- Install this device in the orientation shown below. The operation panel can face any direction.

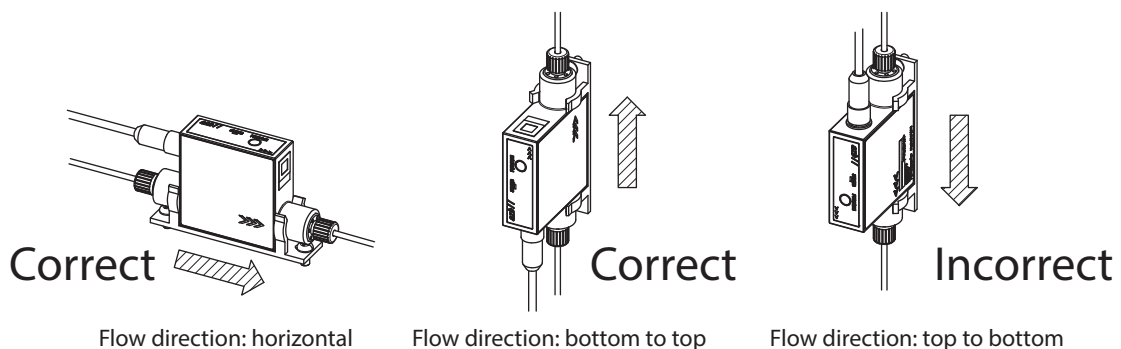

3-2 Wiring

CAUTION

! The power supply circuit and I/O circuit are not isolated. Therefore, ensure that the power supply is isolated from the power supply of external devices. If this device and external devices share a common power supply, faulty operation or device failure may result.

! If there is a risk of a power surge caused by lightning, use a surge absorber (surge protector). Otherwise there is a danger of fire or device failure.

! Make sure that the wiring is correct before turning the power on. Incorrect wiring will cause damage and/or device failure.

Waterproof connector

Connector specifications

HR30-6R-6P (71), made by Hirose Electric Co., Ltd.

Connector pin layout

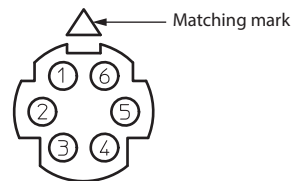

Connector pin signal table

Pin No.	Signal name	Description	Details	Cable color
1	POWER (24 V)	24 V DC (+) power	Rated 24 V DC $\pm 10\%$	Brown
2	ANALOG OUTPUT	Analog output (+)	1–5 V DC (external load resistance: 250 k Ω min.)	Red
3	GND	24 V DC (–) power Digital output (–) Digital input (–)	Common ground for power supply and digital signals	Green
4	DO	Digital output (+)		Orange
5	DI	Digital input (+)		Yellow
6	A.GND	Analog output (–)	Common ground for analog signals	Blue

Note 1. The cable colors are those of F9Y7HP1 and F9Y7HF1, which are sold separately.

Note 2. There is no isolation between outputs.

Note 3. No protection is provided for wrong wiring.

Note 4. If relays are connected to the digital inputs, use relays with gold-plated contacts.

Wiring example

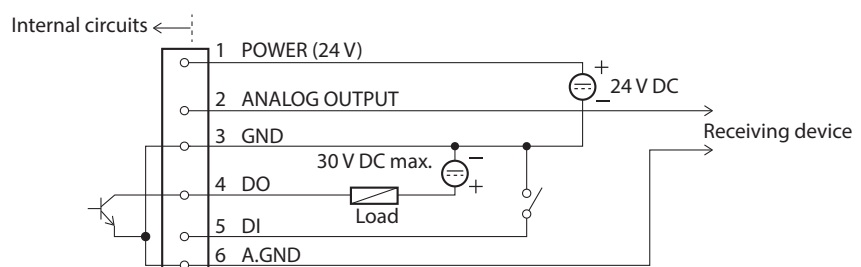

Chapter 4. Startup of the Device

■ Startup of the device

After power-on, the device waits for 10 seconds for PC loader communication to start. I/O will be as follows.

- Analog output: Output of 0 V only continues
- Digital output: Open
- Digital input: Not accepted

Note

- For details on PC loader communications,
 *User's Manual for Smart Loader Package Model SLP-F7M for Micro Flow Rate Liquid Flow Meter Model F7M (CP-SP-1423E)*

Note: If the adapter for loader communication cable (F9Y7A1) is connected to the F7M, the analog output, digital output, and digital input of the F7M cannot be used.

■ Zero point adjustment

The instantaneous flow rate can be set to zero when the fluid in the flow path of this device is not moving. If a fluid with a thermal conductivity different from that of water (H₂O) is measured, zero point adjustment is required.

Adjustment can be done in the following three ways:

- Press and hold the switch on the device for 10 seconds.
- Turn on the digital input for 1 second or more.

Note: To adjust zero point with this method, it is necessary to change the parameter settings in advance using the PC loader. Set DI function under DI settings to Zero point adjustment.

- Execute zero point adjustment using the PC loader.

Handling Precautions

- After zero point adjustment, the adjusted value is recorded in the built-in nonvolatile memory, so it will be reflected in operation the next time the device's power is turned on.
- Do not attempt another zero point adjustment until the current zero adjustment is complete.

● Method of zero point adjustment

Zero point can be adjusted using the following procedure.

- (1) Fill the pipe with the fluid (the fluid cannot contain bubbles).
- (2) Turn the F7M on and wait for 30 minutes (the settling time required for accurate zero point adjustment).
- (3) Check that the fluid is not moving.
- (4) Adjust the zero point using any of the three methods described above. The LED indicator blinks green fast while the zero point data is being acquired (approx. 10 seconds).
- (5) If the LED blinks green three times and then stays lit, zero point adjustment is complete. It is possible to start measurement.

Handling Precautions

- If the LED behaves as follows, zero point adjustment failed. Check that the fluid is completely still (not moving) and that the pipe does not contain bubbles, and try again.
- After zero point adjustment, the LED indicator blinks green three times and then continues to blink (green) slowly (warning indication).
- After zero point adjustment, the LED indicator blinks red three times and then, lit red, blinks slowly (alarm indication).

● Zero point initialization

The zero point can be initialized (restoring the factory setting) using the following procedure.

- (1) Press and hold the switch on the top of the device for 20 seconds.
Note: When the switch is pressed for 10 seconds, the LED indicator blinks green fast. Continue pressing the switch for another 10 seconds.
- (2) When the LED blinks green three times, zero point initialization is complete.
- (3) Measurement can be started when the LED is lit green, which indicates the device is operating properly.

Chapter 5. Advanced Operations

The parameter settings of this device can be checked or changed using Smart Loader Package model SLP-F7M.

Note

- For details on PC loader communications,
 *User's Manual for Smart Loader Package Model SLP-F7M for Micro Flow Rate Liquid Flow Meter Model F7M (CP-SP-1423E)*

Note: If the adapter for loader communication cable (F9Y7A1) is connected to the F7M, the analog output, digital output, and digital input of the F7M cannot be used.



■ List of Parameters

	Parameter	Unit	Measurable range	Factory default
Event setting	Upper limit validity	–	0: Invalid 1: Valid	1
	Flow rate upper limit	% FS	0 to 100.00 %	100.00
	Hysteresis upper limit	% FS	0 to 10.00 %	0.00
	Delay upper limit	s	0 to 60.0 s	0.0
	Lower limit validity	–	0: Invalid 1: Valid	1
	Flow rate lower limit	% FS	0 to 100.00 %	0.00
	Hysteresis lower limit	% FS	0 to 10.00 %	0.00
	Delay lower limit	s	0 to 60.0 s	0.0
DI settings DO settings	DO polarity	–	0: Direct (normally open) 1: Reverse (normally closed)	0
	DO function	–	0: Flow rate event 1 1: Flow rate event 2 2: Error indication output 3: Totalizer pulse output	0
	DI function	–	1: Zero point adjustment 2: Error reset 3: Liquid type selection	2
	Totalizer pulse flow rate	mL/P	0.01, 0.1, 1, 10	0.1
Flow rate correction	Low-flow cutoff value	% FS	0 to 100.0 % FS	1.0
	Filter time constant	s	0 to 60.0 s	0.0
	Flow rate correction factor (CCF)1	–	0 to 100.000	1.000
	Zero point adjustment 1	mW	–5.00 to +5.00	0.00
	Flow rate CCF 2	–	0 to 100.000	1.000
	Zero point adjustment 2	mW	–5.00 to +5.00	0.00
Analog output	Flow rate offset correction value	mL/min	–10.00 to +10.00	0.00
	Span voltage correction factor	–	0.000 to 2.000	1.000
	Zero-point voltage correction value	V	–1.000 to +1.000	0.000
	Output value if error occurs	–	0: Present value 1: Last good value (before error) 2: Specified value (set in “Voltage to output if error occurs”)	0
Function setup	Voltage to output if error occurs	V	0.600 to 6.000 V	0.600
	Automatic setting of flow rate correction factor CCF	–	ON/OFF	OFF
	Temperature-based correction (recommended for fluids with characteristics similar to water)	–	ON/OFF	ON
	Display ON/OFF using DI status	–	ON/OFF	OFF

■ Flow rate calculation processing

1–5 V signals are output for a flow rate in the range from zero to the accuracy-guaranteed upper limit value. The maximum output signal is 5.6 V (115 % of the accuracy-guaranteed flow rate range upper limit). Correction can be applied to the instantaneous flow rate and analog outputs via PC loader communications.

Note

-  Flow rate output correction (p. 11),
-  Analog output correction (p. 12) (for details)

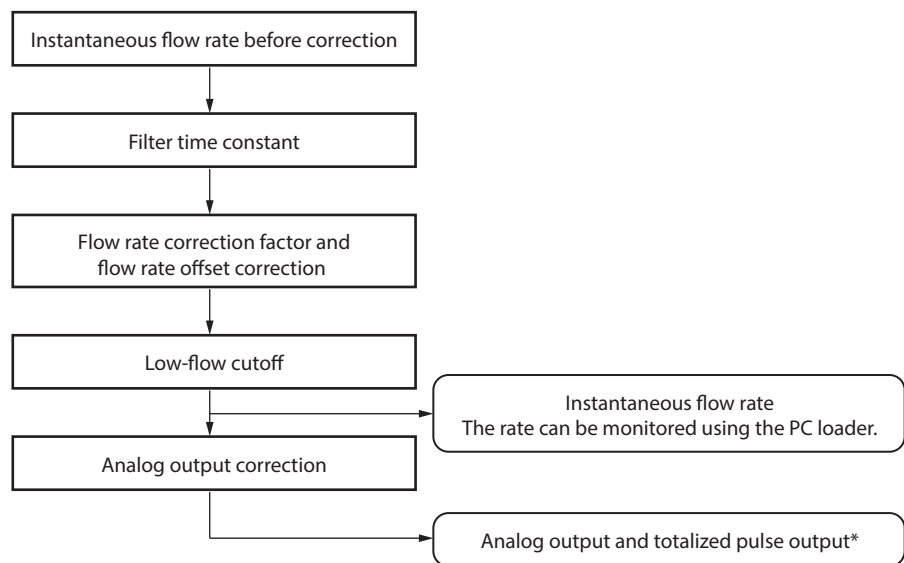

* By setting "DO function" to "3" (Totalizer pulse output) using the PC loader, totalized pulse can be output.

■ Flow rate output correction

Filter time constant, flow rate correction factor, flow rate offset correction value, and low-flow cutoff value can be set for the instantaneous flow rate.

The instantaneous flow rate when the flow rate correction factor and flow rate offset correction value are set can be calculated as follows:

Instantaneous flow rate (mL/min) = flow rate correction factor (CCF) × instantaneous flow rate before correction + flow rate offset correction value

● Filter time constant

Set this constant to minimize fluctuation in the instantaneous flow rate output due to a pulsating flow or electric noise.

A preliminary delay filter is applied to the pre-correction instantaneous flow rate. The greater the filter time constant, the smaller the fluctuation in the instantaneous flow rate. However, responsiveness is also proportionally worse.

Ex.: The filter time constant needed to apply a 1 second time constant filter to the pre-correction instantaneous flow rate = 1.0 s

● **Flow rate correction factor (CCF)**

Set this factor if a fluid with a thermal conductivity different from that of water (H₂O) is measured and if the actual measured flow rate differs from the instantaneous flow rate.

Ex.: If a 30 mL/min model indicates an instantaneous flow rate of 10 mL/min when the actual flow rate is 13 mL/min, set the flow rate correction factor to 1.3.

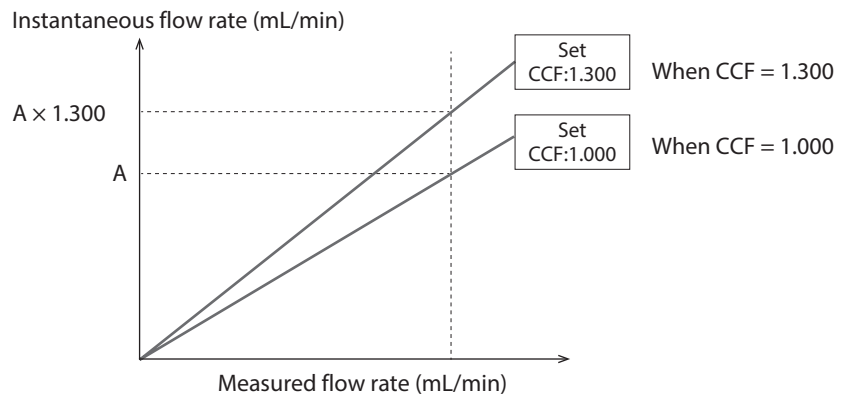

● **Flow rate offset correction value**

Set this value if a fluid with a thermal conductivity different from that of water (H₂O) is measured and if an instantaneous flow rate other than 0 mL/min is indicated even though the fluid is not moving.

Ex.: If an instantaneous flow rate of 0.5 mL/min is indicated when the fluid is not moving, set the flow rate offset correction value to -0.5 mL/min.

● **Low-flow cutoff**

If the flow rate is below the low-flow cutoff value, the device regards the fluid as not moving and sets the instantaneous flow rate and analog outputs to zero.

Note that this function may affect the measured value in low flow rate measurement.

■ **Analog output correction**

It is possible to correct analog output, in addition to flow rate, by setting the span voltage correction factor and zero-point voltage correction value. The output voltage when analog output correction is set can be calculated as follows:

$$\text{Instantaneous flow rate output (V)} = (\text{calculated flow rate} \div \text{flow rate range}) \times 4 \times \text{span voltage correction factor} + (1 + \text{zero-point voltage correction value})$$

Also, the value to be output at the time an error occurs can be set.

● **Span voltage correction factor**

By setting the span voltage correction factor, the flow rate corresponding to 100 % analog output (5 V) can be set.

Ex.: For a 30 mL/min model, if 1–5 V signals are output for the measurement range of 0–20 mL/min, set the span voltage correction factor to 1.500.

● Zero-point voltage correction value

By setting this value, it possible to correct an error in the analog output that is caused by installation environment or wiring.

Ex.: If there is an error of 0.5 V in the analog output, set the zero-point voltage correction value to -0.5 V.

● Analog output value at the time an error occurs

The value to be output at the time an error occurs can be selected from the following three options using the loader.

- Present value
The present calculated flow rate is output regardless of the type of the abnormality.
- Last good value
The last good value before the error occurred is output.
- Specified value
The value set in [Voltage to output if error occurs] is output.

■ Digital input functions

Connect non-voltage contacts or an open collector. The following functions can be set using the PC loader.

- Zero point adjustment
- Error reset
- Liquid type selection

● Liquid type selection (ID code "b" and later)

With digital input switching, this device can be used alternately for two types of liquid. The available liquid type settings are:

- Liquid type 1: flow rate CCF 1, zero point adjustment 1
- Liquid type 2: flow rate CCF 2, zero point adjustment 2

By setting "Liquid type selection" for the digital input function, the setting for liquid type 1 or 2 can be switched by digital input.

When digital input is OFF (contacts open), liquid type 1 is selected, and when DI is ON (contacts closed), liquid type 2 is selected.

If zero point adjustment is executed, whichever liquid type is selected by the digital input will be the target of adjustment.

If something other than "Liquid type selection" is set for the digital input function, liquid type 1 is usually selected.

■ Digital output functions

The following functions can be set using the PC loader.

- Flow rate event 1
- Flow rate event 2
- Totalizer pulse output
- Error indication output

● Flow rate event 1: Flow rate upper or lower limit event with hysteresis setting

When “DO polarity” is set to “0” (direct), if the flow rate exceeds the upper limit, digital output is turned on. If the flow rate is below the lower limit, digital output is turned off (the operation is reversed if “DO polarity” is set to “1” (reverse)). Delay time can be set separately for upper and lower limits.

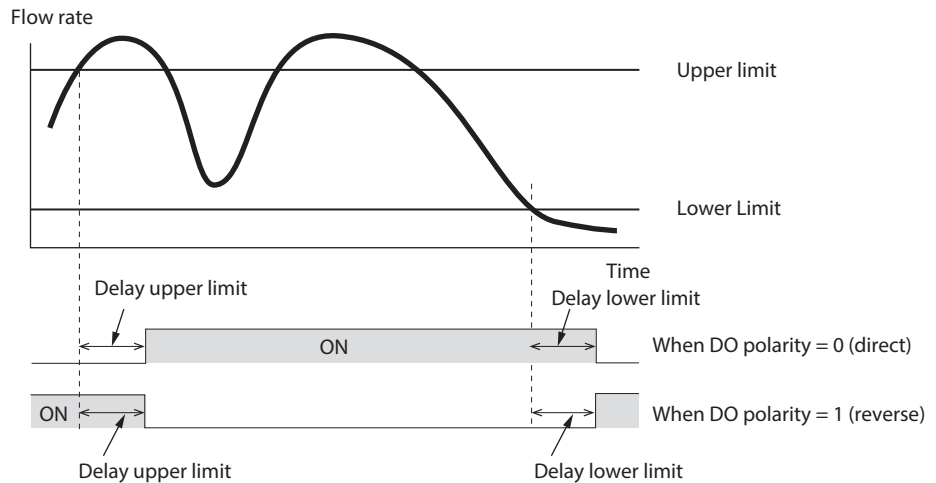

● Flow rate event 2: Flow rate upper or lower limit event

If the flow rate exceeds the set upper or lower limit, digital output is turned on or off (the operation is reversed if “DO polarity” is set to “1” (reverse)). Delay time can be set separately for upper and lower limits. Delay time cannot be set for hysteresis.

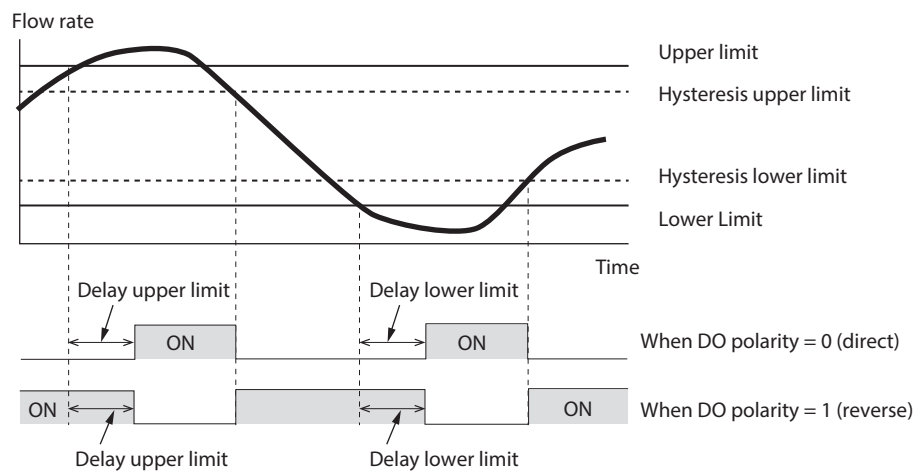

● Totalizer pulse output

Every time the set totalizer pulse flow rate is reached, a 5 ms pulse is output. The totalizer pulse flow rate can be selected from 0.01, 0.1, 1, and 10 mL/P.

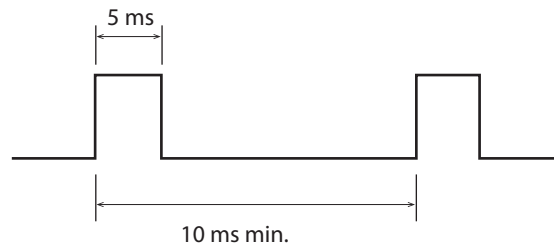

Note: The output cycle depends on the flow rate.

● Error indication output

Digital output is turned on if an error or alarm indicated in “Abnormal status and corrective actions” in Chapter 6 occurs.

Digital output is not turned on if a warning occurs. Abnormal status can be checked by the PC loader.

■ Function setup

● Automatic setting of flow rate correction factor (CCF) (ID code “b” and later)

This function automatically sets the flow rate CCF based on the amount of adjustment after zero point adjustment. If this function is used to automatically set the CCF, flow rate accuracy is not guaranteed.

For higher accuracy, use the set value as a guideline for setting the CCF manually. Especially in the case of a liquid whose thermal conductivity is less than 0.138 W/mK (equivalent to 100 % isopropyl alcohol), a large error may occur.

If “Liquid type selection” is set for the digital input function, the flow rate CCF of the selected liquid type is automatically set. When the device is shipped, “Automatic setting of flow rate correction factor (CCF)” is set to OFF.

● Temperature-based correction (ID code “b” and later)

Measurement error due to the temperature of the fluid can be corrected with this function.

The temperature characteristic value of water (H₂O) is used to correct the temperature of the fluid.

When the device is shipped, “Temperature-based correction” is set to ON.

If the fluid has characteristics similar to water, setting “Temperature-based correction” to “ON” is recommended. If the fluid does not have characteristics similar to water and if there is a large measurement error due to the temperature of the fluid, setting this function to “OFF” may reduce the error.

● Display ON/OFF using DI status (ID code “b” and later)

When digital input is ON (contacts closed), the top panel LED of this device is lit simultaneously red and green.

When the device is shipped, “Display ON/OFF using DI status” is set to OFF.

Chapter 6. Troubleshooting

■ Types of abnormal status

There are four types of abnormal status: Error, alarm, warning, and information. Abnormal status can be checked by the PC loader.

● Error

An error has a significant impact on the operation of this device. If an error occurs, flow rate measurement stops. If it is caused by a transient failure such as electrical noise, the device may return to normal status after its power is turned off and back on. If not, the device may have failed. Replace the product.

● Alarm

An alarm affects the measurement of flow rate. If an alarm occurs, flow rate measurement continues, but the accuracy of the flow rate is not guaranteed.

● Warning

A warning has a small impact on the measurement of flow rate. If a warning occurs, digital output remains off when "DO function" is set to "Error indication output." Whether a warning has occurred can be checked with the LED indicator or by the PC loader. If a warning occurs, flow rate measurement continues.

● Information

This status does not necessarily indicate a problem. Information is displayed by the PC loader for reference.

■ Abnormal status and corrective actions

Type
 Er: Error
 Al: Alarm
 Wn: Warning
 Inf: Information

Automatic recovery √: Yes (when the cause is removed, the abnormal status indication disappears)
 -: No

No.	Type	Description	Supposed cause	Countermeasures	Automatic recovery
0	Al	Zero point adjustment error (correction of more than $\pm 40\%$ FS)	The zero point was adjusted when the fluid was moving.	Check that the pipe is full of the fluid to be measured and that the fluid is not moving, and try again.	√
	Wn	Zero point adjustment completed (correction of more than $\pm 25\%$ FS)			
	Inf	Zero point adjustment succeeded	Zero point adjustment succeeded.	—	
1	Wn	Empty (flow path not full)	The flow path of this device has not been full for some time.	Fill the flow path with the fluid.	√
	Inf	Flow rate measurement error	A flow rate measurement error occurred due to a cause such as bubbles in the flow path.	Check for problems in the installation environment or instrumentation.	

No.	Type	Description	Supposed cause	Countermeasures	Automatic recovery
2	Wn	Accuracy-guaranteed flow rate exceeded	Fluid is flowing at a rate greater than the rated (accuracy-guaranteed) flow rate.	Use this device within the rated flow rate range.	✓
3	Wn	Analog output range exceeded	The rated flow rate was exceeded, or an analog output correction parameter value is invalid.	Use this device within the rated flow rate range. Set a valid parameter value.	✓
4	Wn	Parameter error (1) Checksum error (2) Number of write cycles exceeded	(1) A checksum error occurred during parameter data reading or writing. (2) Parameters were written more than the specified number of times.	(1) Write parameters again. (2) Replace the product.	–
5	Wn	Watchdog time-out	A reset by a communication command, or malfunction due to electrical noise, etc.	If the warning persists after turning the power off and back on, the device may have failed. Replace the product.	–
6	Al	Flow path or circuit temperature out of range	The sensor unit has failed.	<ul style="list-style-type: none"> Check that the fluid temperature and the ambient temperature meet the specified operating conditions. If the alarm persists after turning the power off and back on, the device may have failed. Replace the product. 	–
	Wn		The fluid temperature or the ambient temperature does not meet the specified operating conditions.		
7	Al	Measurable flow rate exceeded	The flow rate is greater than 115 % of the measurable range.	Use this device within the rated flow rate range.	✓
8	Al	Totalizer pulse output error (flow over range)	When totalizer pulse was being output, the flow rate exceeded the rated measurable range for a certain period of time.	Use this device within the rated flow rate range.	✓
	Wn		When totalizer pulse was being output, the flow rate far exceeded the rated measurable range for a certain period of time.		
9	–	(Not used)	—	—	
10	Al	Heater control error	<ul style="list-style-type: none"> The heater or temperature sensor has failed. The electric circuit has failed. 	If the alarm persists after turning the power off and back on, the device may have failed. Replace the product.	✓
11	Er	Parameter error	A type of parameter not supported by this device, or an illegal parameter value, was downloaded by the PC loader.	If the error, alarm, or information persists after changing the parameter setting and turning the power off and back on, the device may have failed. Replace the product.	–
	Al	Parameter mismatch	Parameter values are abnormal, etc.		
	Inf	Out-of-range parameter	Parameter values are out of range.		
12	Er	Nonvolatile memory error	The data in the device is corrupt.	If the error persists after changing the parameter setting turning the power off and back on, the device may have failed. Replace the product.	–
		Backup parameter error	The data in the backup field is corrupt.		
13	Er	Software execution error	<ul style="list-style-type: none"> The heater or temperature sensor has failed. The electric circuit has failed. 	If the error persists after turning the power off and back on, the device may have failed. Replace the product.	–
14	Er	Hardware error	<ul style="list-style-type: none"> The heater or temperature sensor has failed. The electric circuit has failed. 	If the error persists after turning the power off and back on, the device may have failed. Replace the product.	–
15	Er	Program ROM error	Data discrepancy was detected in a cyclic redundancy check (CRC) of the ROM.	If the error persists after turning the power off and back on, the device may have failed. Replace the product.	–

■ Other problems

Description	Supposed cause	Countermeasures
Flow rate is zero but flow rate output does not read zero.	A fluid with a thermal conductivity higher than that of water (H ₂ O) is being measured.	<ul style="list-style-type: none"> • Adjust the zero point. • Set the flow rate correction factor using the PC loader.
Flow rate is not output even though fluid is flowing into the pipe.	<ul style="list-style-type: none"> • A fluid with a thermal conductivity lower than that of water (H₂O) is being measured. • The adapter for loader communication cable (F9Y7A1) is connected. 	<ul style="list-style-type: none"> • Adjust the zero point. • Set the flow rate correction factor using the PC loader. • For normal use, connect the F9Y7H_1 cable directly to the F7M without using the adapter for loader communication cable (F9Y7A1). • For details, see section 1-2, "Hardware Configuration," of <i>User's Manual for Smart Loader Package Model SLP-F7M for Micro Flow Rate Liquid Flow Meter Model F7M</i> (CP-SP-1423E).
Flow rate output does not stabilize (fluctuation or drift of output)	<ul style="list-style-type: none"> • A mixed fluid is being measured. • The fluid is pulsating. • The fluid contain bubbles. • There are sources of electrical noise near the flowmeter. • The flowmeter is exposed to vibration. 	<ul style="list-style-type: none"> • Make sure that the fluids are equally mixed. • Set the flow rate correction factor using the PC loader. • Take appropriate measures so that no bubbles are included with the fluid. • Remove the source of electrical noise. • Install this device in a place without vibration.
The flow rate output (instantaneous flow rate) is different from the actual flow rate	<ul style="list-style-type: none"> • A mixed fluid is being measured. • A fluid other than H₂O is being measured. • The length of the straight pipe is insufficient. 	<ul style="list-style-type: none"> • Measure the fluid at a position where the fluids are equally mixed. • Set the flow rate correction factor using the PC loader. • Install a straight pipe with the specified length.
Digital signal is not output.	<ul style="list-style-type: none"> • The wiring is wrong. • The receiver does not satisfy the pulse output specifications of this device. • The adapter for loader communication cable (F9Y7A1) is connected. 	<ul style="list-style-type: none"> • Check that the wiring for the digital output is correct. • Use a receiver that satisfies the pulse output specifications (for pulse width, frequency, and voltage drop). • For normal use, connect the F9Y7H_1 cable directly to the F7M without using the adapter for loader communication cable (F9Y7A1). • For details, see section 1-2, "Hardware Configuration," of <i>User's Manual for Smart Loader Package Model SLP-F7M for Micro Flow Rate Liquid Flow Meter Model F7M</i> (CP-SP-1423E).
Loader communication is unavailable.	<ul style="list-style-type: none"> • The wiring is wrong. • The device is not in loader communication mode. 	<ul style="list-style-type: none"> • Check that the wiring is correct. • Turn the power of the device off and back on and try loader communication again. •  For details, see section 1-2, "Hardware Configuration," and 3-2, "Connecting the Loader to the Device," of <i>User's Manual for Smart Loader Package Model SLP-F7M for Micro Flow Rate Liquid Flow Meter Model F7M</i> (CP-SP-1423E).
Digital input does not work.	<ul style="list-style-type: none"> • The adapter for loader communication cable (F9Y7A1) is connected. 	<ul style="list-style-type: none"> • For normal use, connect the F9Y7H_1 cable directly to the F7M without using the adapter for loader communication cable (F9Y7A1). • For details, see section 1-2, "Hardware Configuration," of <i>User's Manual for Smart Loader Package Model SLP-F7M for Micro Flow Rate Liquid Flow Meter Model F7M</i> (CP-SP-1423E).

Chapter 7. Specifications

■ General specifications

Model No.		F7M9010	F7M9030	F7M9050
Accuracy-guaranteed flow rate upper limit (fluid: water (H ₂ O))		10 mL/min	30 mL/min	50 mL/min
Measurable fluid		Fluid that does not clog the flow path and does not corrode or damage the wetted material used in the flow path (fused quartz glass tube, PFA or PTFE fitting) <ul style="list-style-type: none"> • If the fluid adheres to the internal wall of the flow path, measurement error will result. • The measurement range differs for fluids other than water (H₂O). 		
Accuracy-guaranteed fluid		Water (H ₂ O)		
Measurement accuracy* ¹ (under standard conditions)		±5 % rdg. (at 20 % or more of the FS), ±1 % FS (at less than 20 % of the FS)		
Measurable flow rate range (fluid: water (H ₂ O))		0.1 to 11.5 mL/min (1 to 115 % FS)	0.3 to 34.5 mL/min (1 to 115 % FS)	0.5 to 57.5 mL/min (1 to 115 % FS)
Accuracy-guaranteed flow rate range (fluid: water (H ₂ O))		0.2 to 10 mL/min (2 to 100 % FS)* ⁴	0.6 to 30 mL/min (2 to 100 % FS)* ⁴	1.0 to 50 mL/min (2 to 100 % FS)* ⁴
Min. measurable flow rate (fluid: water (H ₂ O))		0.1 mL/min* ⁵	0.3 mL/min* ⁵	0.5 mL/min* ⁵
Repeatability* ³ (under standard conditions)* ²		±1 % rdg. (at 20 % or more of the FS), ±0.2 % FS (at less than 20 % of the FS)		
Responsiveness (fluid: water (H ₂ O))		1.0 s typ. (63.2 % response)		
Temperature characteristics (fluid: water (H ₂ O))		±0.5 % rdg./°C This figure compares the output values when both the fluid and ambient temperatures are at 23 °C (standard conditions) and when both temperatures are in the 10–35 °C range.		
Mounting orientation		Horizontal or vertical* ⁶		
Process fluid pressure range		0 to 500 kPa (gauge)		
Pressure resistance		700 kPa (gauge)		
Operating conditions	Fluid temperature range	5 to 50 °C * ⁸		
	Ambient temperature range	5 to 50 °C * ⁸		
	Ambient humidity	10 to 90 % RH (without condensation on the exterior or interior of the product)* ⁸		
	Vibration	None		
	Shock	None		
Transport/storage conditions	Ambient temperature range	5 to 60 °C		
	Ambient humidity	10 to 90 % RH		
	Vibration resistance	4.9 m/s ²		
	Shock resistance	490 m/s ² (when packed)		
Straight pipe length (fluid: water (H ₂ O))		50 mm		
Wire pullout strength		30 N		
Fitting pullout strength		30 N		
Power	Rated power	24 V DC		
	Allowable voltage range	21.6 to 26.4 V DC (ripple: 2.5 % max.)		
	Power consumption	0.7 W max.		
Analog output	Output range	1 to 5 V* ⁵		
	Maximum output voltage	5.6 V (115 %) (at max. measurable flow rate)		
	External load resistance	250 kΩ min.		
	Output update cycle	10 ms		
	Output accuracy	0.02 % max.		
Digital output	Number of outputs	1		
	Functions	Any of the following functions can be set by the PC loader. <ul style="list-style-type: none"> • Flow rate event 1: Flow rate upper or lower limit event with hysteresis setting • Flow rate event 2: Flow rate upper or lower limit event • Totalizer pulse output • Error indication output 		

Model No.		F7M9010	F7M9030	F7M9050
Digital output	Output rating	NPN open collector non-isolated output, when power off: open contacts External power supply: 30 V DC max., maximum load current: 30 mA max.		
	Totalizer pulse (when totalizer pulse output is selected)	Totalizer pulse flow rate: 0.01, 0.1, 1, 10 mL/P (selectable using the PC loader) Pulse width: 5 ms typ.		
Digital input	Number of inputs	1		
	Functions	Any of the following functions can be set by the PC loader. • Zero point adjustment • Error reset • Liquid type selection		
	Circuit type	Non-voltage contacts or open collector		
	Allowable ON contact resistance	250 Ω max.		
	Allowable OFF contact resistance	100 kΩ min.		
	Allowable ON residual voltage	0.8 V max.		
	ON terminal current	0.5 mA (when contact resistance is 250 Ω)		
Warm-up time		30 min or longer after power-on*7		
Piping connection method (compatible tube)		PFA tube fitting P series Super 300 Type Pillar Fitting made by Nippon Pillar Packing Co., Ltd Compatible tube: Outer dia. 3 mm, inner dia. 2 mm (for metric system), Outer dia. 1/8 inch, inner dia. 0.086 inch (for inch system)		
Protection rating		IP65		
Weight		85 g		
Standards and regulations compliance		EN 61326-1, EN 61326-2-3		

*1. The instrumental error in the volumetric flow rate was measured by Azbil's fluid flow rate calibration equipment.

*2. The standard conditions are as follows.

Fluid	Water (H ₂ O) without bubbles, pulsation, etc.
Fluid temperature	23 °C
Ambient temperature	23 °C
Fluid pressure	250 kPa
Vibration	0 m/s ²
Stabilization time	Before starting measurement, leave the fluid at an ambient temperature of 23 °C for 2 hours or longer, turn on the power, wait for 30 min or longer until the device stabilizes, and leave the fluid for another 10 min or longer.
Mounting orientation	Horizontal piping with the top panel facing upward
Output signal	Instantaneous flow rate (analog output (1–5 V))

*3. The repeatability indicates the variation in output signals at a steady flow rate under standard conditions, with this device mounted on the pipe.

*4. This device cannot measure the flow rate of fluid that flows in the reverse direction. If the flow direction is reversed, this device outputs a flow rate without indicating an error, but the output value is not equal to the output for a regular forward flow at the same rate.

*5. If the flow rate is below the minimum measurable rate, the output signal is always 0 % (1 V).

*6. If this device is mounted in an orientation that is different from the one specified in the standard conditions, there is an error of about ±1 % rdg. in measurements when compared with the standard mounting.

*7. Warm-up time is the time after power-on until the output signal of this device reaches its final value (within ±1 % rdg. of the flow rate converted from the analog output) after stabilization of the flow rate. It is possible to measure the flow rate without waiting for 30 minutes, but if precise measurement is required, allow the specified warm-up time.

*8. Depending on the ambient humidity, condensation can occur if the temperature of the fluid drops below the ambient temperature.

Parts sold separately

Name	Part No.	Note
PVC-insulated cable, 2 m	F9Y7HP1	Cable assembly with a waterproof connector
Fluororesin-insulated cable, 2 m	F9Y7HF1	Waterproof connector model No.: HR30-6P-6S (31), made by Hirose Electric Co., Ltd.
Fitting (metric system), 2 sets	F9Y7F1	Sleeves, union nuts (outer dia. 3 mm, inner dia. 2 mm), the same as the included parts
Fitting (inch system), 2 sets	F9Y7F2	Sleeves, union nuts (outer dia. 1/8 inch, inner dia. 0.086 inch), the same as the included parts
Mounting bracket	F9Y7B1	Same as the included part
Fluororesin tube assembly (metric system), 2 sets	F9Y7T1	Sleeve-inserted tube assembly (outer dia. 3 mm, inner dia. 2 mm, length 500 mm)
Fluororesin tube assembly (inch system), 2 sets	F9Y7T2	Sleeve-inserted tube assembly (outer dia. 1/8 inch, inner dia. 0.086 inch, length 500 mm)
Fluororesin tube assembly for metal pipes (female thread), 2 sets	F9Y7T3	An assembly of conversion adapters and a fluororesin tube for metal pipes Conversion adapter: Rc 1/8 (wetted part material: SUS316), Tube: Outer dia. 1/8 inch, length 200 mm
Fluororesin tube assembly for metal pipes (male thread), 2 sets	F9Y7T5	An assembly of conversion adapters and a fluororesin tube for metal pipes Conversion adapter: R 1/8 (wetted part material: SUS316), Tube: Outer dia. 1/8 inch, length 200 mm
Fluororesin tube assembly (dia. 4 mm tube) for easy-install tube fittings, 2 sets	F9Y7T6	Set of fluororesin tube and easy-install tube fittings Easy-install tube fitting: for a 4 mm dia. tube (wetted part material: SUS316), Tube: Outer dia. 1/8 inch, length 200 mm
Adapter for loader communication cable	F9Y7A1	For PC loader Note: The PC loader can be downloaded from the following website (Japanese only): https://www.compclub.com

● F9Y7HP1, F9Y7HF1 (cable)

Unit: mm

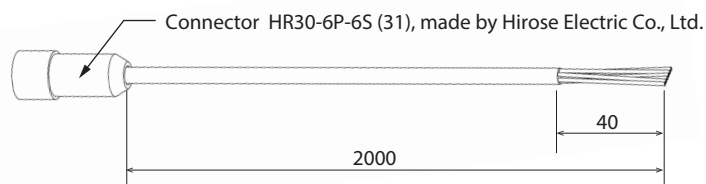

● Composition of the cable

	F9Y7HP1		F9Y7HF1	
	Material	Dimensions	Material	Dimensions
Sheath	PVC (black)	Outer dia.: 4.7 mm	Protective layer: FEP (black) Sheath: PVC	Outer dia.: 4.6 mm
Holding tape	Paper	—	EPTFE	Thickness: 0.1 mm
Insulator	PVC (6 colors)	Outer dia.: 0.8 mm	ETFE (6 colors)	Outer dia.: 0.89 mm
Conductor	Tin-plated soft steel wire	AWG26	Tin-plated soft steel wire	AWG25
Dielectric strength	500 V		500 V	
Conductor resistance	139 Ω /km max.		100 Ω /km max.	
Rated temperature	80 °C		80 °C	

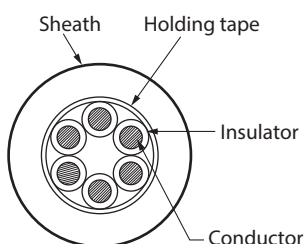

● F9Y7F1, F9Y7F2 (A set of fittings)

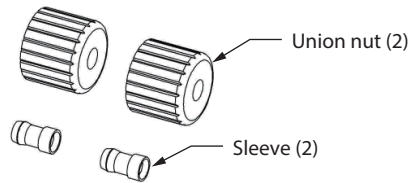

● F9Y7B1 (mounting bracket)

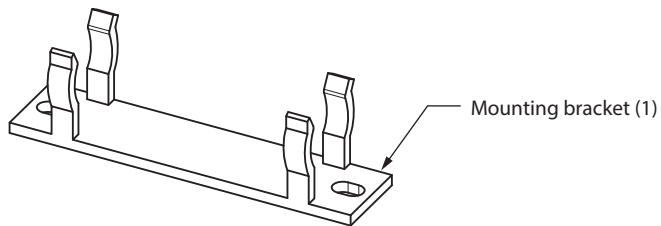

● F9Y7T1 (fluororesin tube assembly)

Unit: mm

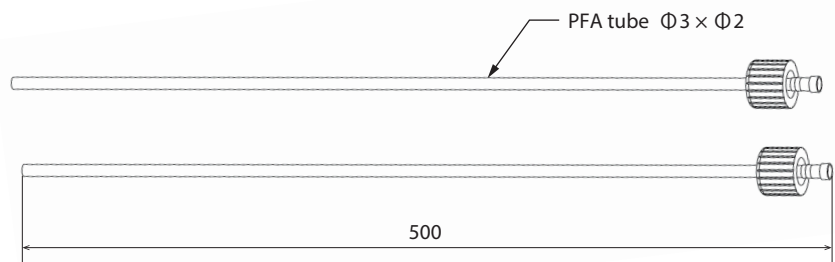

● F9Y7T2 (fluororesin tube assembly)

Unit: mm

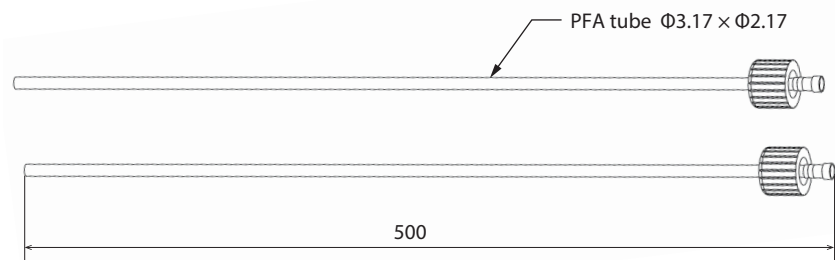

● F9Y7T3 (fluororesin tube assembly for metal pipes)

Unit: mm

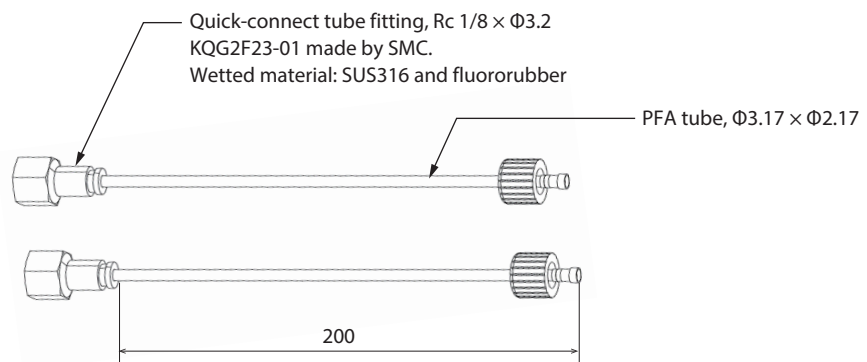

● F9Y7T5 (fluororesin tube assembly for metal pipes)

Unit: mm

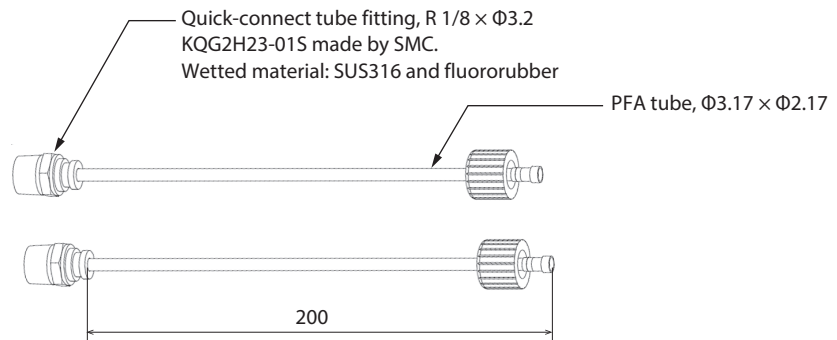

● F9Y7T6 (Fluororesin tube assembly for easy-install tube fittings)

Unit: mm

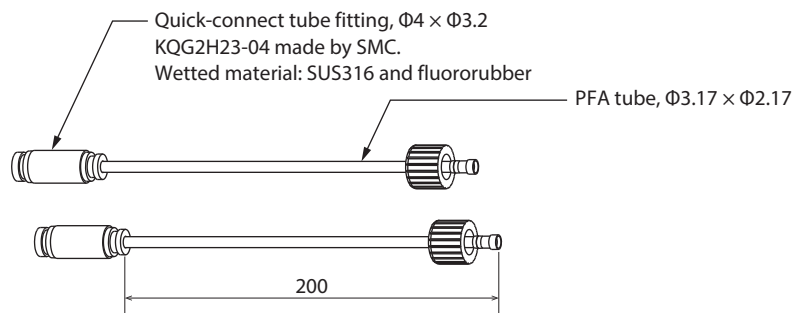

■ External dimensions

Unit: mm

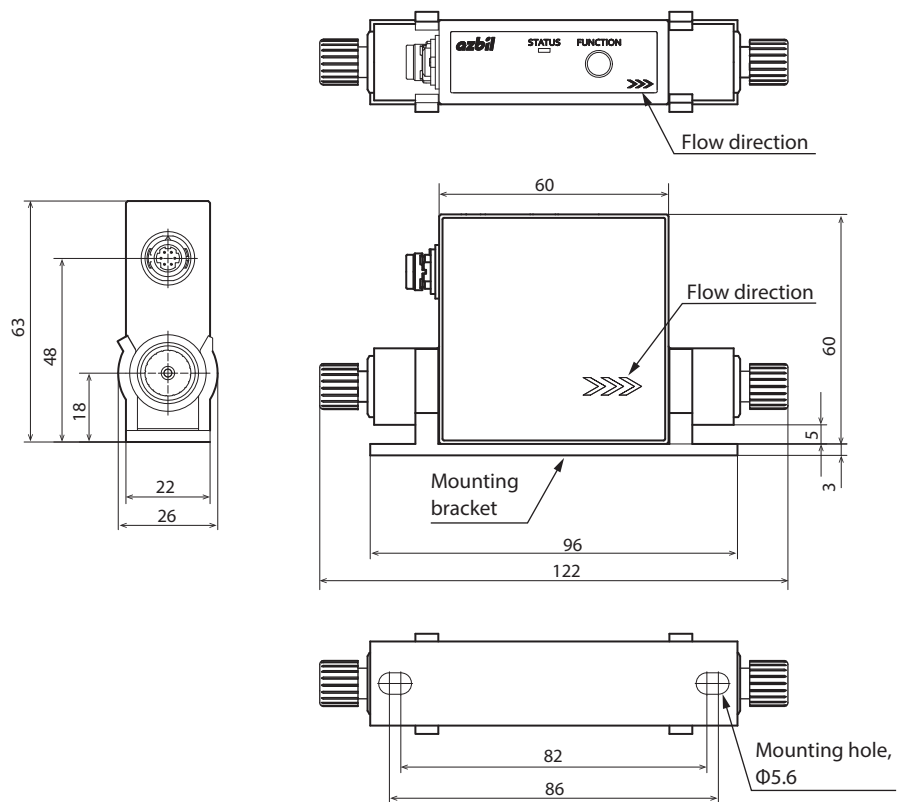

■ Label

The label on the back of the main unit indicates the following information.

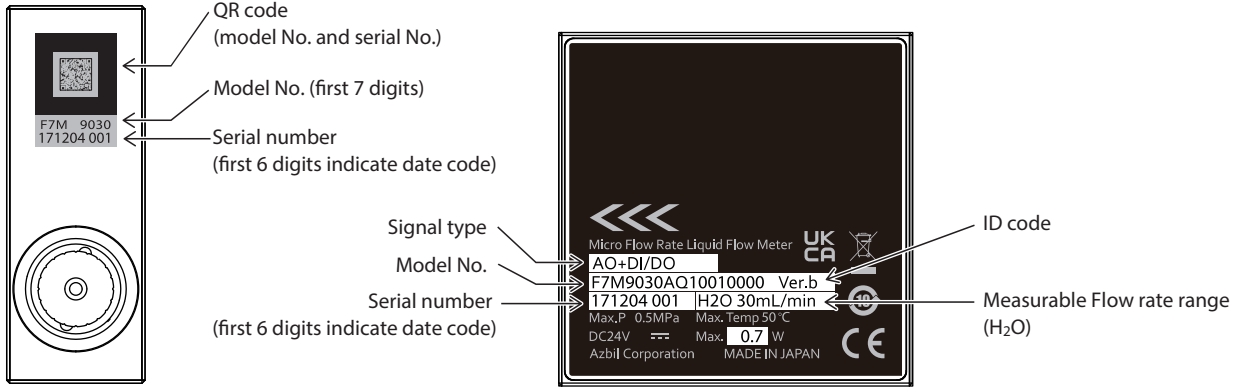

SAFETY SHEET

In accordance with the amendment of the Industrial Safety and Health Act in Japan, which came into effect on April 1, 2006, Azbil Corporation asks its customers to submit a copy of this Safety Sheet before sending us a device for investigation. The Safety Sheet is intended to ensure that the customer's device is safe for repair personnel and to ensure environmentally proper handling.

After you have submitted this sheet in advance, we will examine it to determine whether or not we can undertake an investigation of the product.

Please complete the Safety Sheet and submit it before sending us a device.

Please print this page.

Note 1. If a liquid other than water was used, clean the parts that came into contact with the liquid and send them in a safe state.

Note 2. Completely remove the liquid that was used and cleaning fluid residues.

Note 3. If there is a possibility that harmful substances remain inside the product, attach the safety data sheet (SDS) for the liquid used. After this sheet is submitted in advance, we will examine it to determine whether or not to accept investigation of the product.

To: Azbil Corporation	End User Statement
1. Usage of the returned product	
I attest that the status of the product for which the survey is requested is as described below. (Check (✓) the applicable check box and enter details)	
Liquid used in the device	
<input type="checkbox"/> Water	→ Go to part 2, "Returned product information"
<input type="checkbox"/> Other liquid	→ Fill in the following items and also part 2, "Returned product information"
→Liquid name and other details: _____	
Flow path cleaning if a liquid other than water was used	
<input type="checkbox"/> Liquid residue used in the product was completely removed (without a cleaning solution)	
<input type="checkbox"/> Liquid residue used in the product was completely removed (with a cleaning solution)	
→ Name of the cleaning solution used: _____	
<input type="checkbox"/> Liquid used in the product may remain in the device.	
<input type="checkbox"/> The residue is harmless.	→ Attach an SDS to this document.
<input type="checkbox"/> The residue is harmful.	→ We cannot undertake investigation of the product.
2. Returned product information	
<u>Model number:</u> _____	(Ex.: F7M9030AQ100100D0)
<u>Date code:</u> _____	(Ex.: 181112)
<u>Serial number:</u> _____	(Ex.: 008)
Year Month Day	<u>Company name:</u> _____
	<u>Dept. name:</u> _____
	<u>Applicant name:</u> _____ <i>Signature</i>
	<u>Approved by :</u> _____ <i>Signature</i>
	<u>Phone:</u> _____
<u>Notes/remarks</u>	

Dealer/Agent/Azbil Salesperson Information			
Year	Month	Day	<u>Company name:</u> _____
			<u>Dept. name:</u> _____
			<u>Salesperson name:</u> _____ <i>Signature</i>
			<u>Phone:</u> _____
Year	Month	Day	<u>Company name:</u> _____
			<u>Dept. name:</u> _____
			<u>Salesperson name:</u> _____ <i>Signature</i>
			<u>Phone:</u> _____

Note

Depending on the state of contamination and residue, we may not be able to undertake an investigation.

Handling of personal information

We will use personal information provided to us only for the above purpose, in keeping with our privacy policy.

-MEMO-

Revision History of CP-SP-1421E

Date	Rev.	(New) Page No.	Description
Feb. 2012	1		
Apr. 2019	2	1-1 5-1 5-3 5-4 5-6 7-1 7-2 7-5 7-6 End of the manual	<ul style="list-style-type: none"> ■ Model selection guide was changed. ■ List of parameters (table) was changed. ● Flow correction factor was changed to flow rate CCF. ■ Digital input function: “Liquid type selection” was added. ■ Function setup section was added. ■ General specifications: Product model number F7M9050 was added. “Liquid type selection” was added to the digital input function. ■ Optional parts list (table) was changed. F9Y7T6 tube figure was added. ■ External dimensions diagram: Distance between mounting holes was changed from 80 to 82. ■ Display label: ID code was added. Terms and Conditions were changed (to version No. AA511A-014-10).
Nov. 2019	3	ii, 7 1 2	<ul style="list-style-type: none"> Page constitution was changed. CAUTION was changed. ■ Model Selection: “With inspection report and traceability certificate” was added. Note was changed. SAFETY SHEET was changed.
Nov. 2021	4	8 10 15 16 17 18 21 24	<ul style="list-style-type: none"> ■ Startup of the device: Note was added. Note was added. ■ List of Parameters (table): Parameter name was changed. ■ Function setup: Description was changed. ■ Types of abnormal status: Description was changed. ■ Abnormal status and corrective actions (table): Description was changed. ■ Other problems (table): Description was changed. ■ Parts sold separately: Description was changed. ■ Label: The figure was changed.
Feb. 2024	5	19, 20	<ul style="list-style-type: none"> ■ General specifications: Added *8.

Terms and Conditions

We would like to express our appreciation for your purchase and use of Azbil Corporation's products.

You are required to acknowledge and agree upon the following terms and conditions for your purchase of Azbil Corporation's products (system products, field instruments, control valves, and control products), unless otherwise stated in any separate document, including, without limitation, estimation sheets, written agreements, catalogs, specifications and instruction manuals.

1. Warranty period and warranty scope

1.1 Warranty period

Azbil Corporation's products shall be warranted for one (1) year from the date of your purchase of the said products or the delivery of the said products to a place designated by you.

1.2 Warranty scope

In the event that Azbil Corporation's product has any failure attributable to azbil during the aforementioned warranty period, Azbil Corporation shall, without charge, deliver a replacement for the said product to the place where you purchased, or repair the said product and deliver it to the aforementioned place. Notwithstanding the foregoing, any failure falling under one of the following shall not be covered under this warranty:

- (1) Failure caused by your improper use of azbil product (noncompliance with conditions, environment of use, precautions, etc. set forth in catalogs, specifications, instruction manuals, etc.);
- (2) Failure caused for other reasons than Azbil Corporation's product;
- (3) Failure caused by any modification or repair made by any person other than Azbil Corporation or Azbil Corporation's subcontractors;
- (4) Failure caused by your use of Azbil Corporation's product in a manner not conforming to the intended usage of that product;
- (5) Failure that the state-of-the-art at the time of Azbil Corporation's shipment did not allow Azbil Corporation to predict; or
- (6) Failure that arose from any reason not attributable to Azbil Corporation, including, without limitation, acts of God, disasters, and actions taken by a third party.

Please note that the term "warranty" as used herein refers to equipment-only-warranty, and Azbil Corporation shall not be liable for any damages, including direct, indirect, special, incidental or consequential damages in connection with or arising out of Azbil Corporation's products.

2. Ascertainment of suitability

You are required to ascertain the suitability of Azbil Corporation's product in case of your use of the same with your machinery, equipment, etc. (hereinafter referred to as "Equipment") on your own responsibility, taking the following matters into consideration:

- (1) Regulations and standards or laws that your Equipment is to comply with.
- (2) Examples of application described in any documents provided by Azbil Corporation are for your reference purpose only, and you are required to check the functions and safety of your Equipment prior to your use.
- (3) Measures to be taken to secure the required level of the reliability and safety of your Equipment in your use
Although azbil is constantly making efforts to improve the quality and reliability of Azbil Corporation's products, there exists a possibility that parts and machinery may break down. You are required to provide your Equipment with safety design such as fool-proof design,*1 and fail-safe design*2 (anti-flame propagation design, etc.), whereby preventing any occurrence of physical injuries, fires, significant damage, and so forth. Furthermore, fault avoidance,*3 fault tolerance,*4 or the like should be incorporated so that the said Equipment can satisfy the level of reliability and safety required for your use.

*1. A design that is safe even if the user makes an error.

*2. A design that is safe even if the device fails.

*3. Avoidance of device failure by using highly reliable components, etc.

*4. The use of redundancy.

3. Precautions and restrictions on application

3.1 Restrictions on application

Please follow the table below for use in nuclear power or radiation-related equipment.

	Nuclear power quality*5 required	Nuclear power quality*5 not required
Within a radiation controlled area*6	Cannot be used (except for limit switches for nuclear power*7)	Cannot be used (except for limit switches for nuclear power*7)
Outside a radiation controlled area*6	Cannot be used (except for limit switches for nuclear power*7)	Can be used

*5. Nuclear power quality: compliance with JEAG 4121 required

*6. Radiation controlled area: an area governed by the requirements of article 3 of "Rules on the Prevention of Harm from Ionizing Radiation," article 2 2 4 of "Regulations on Installation and Operation of Nuclear Reactors for Practical Power Generation," article 4 of "Determining the Quantity, etc., of Radiation-Emitting Isotopes," etc.

*7. Limit switch for nuclear power: a limit switch designed, manufactured and sold according to IEEE 382 and JEAG 4121.

Any Azbil Corporation's products shall not be used for/with medical equipment.

The products are for industrial use. Do not allow general consumers to install or use any Azbil Corporation's product. However, azbil products can be incorporated into products used by general consumers. If you intend to use a product for that purpose, please contact one of our sales representatives.

3.2 Precautions on application

you are required to conduct a consultation with our sales representative and understand detail specifications, cautions for operation, and so forth by reference to catalogs, specifications, instruction manual, etc. in case that you intend to use azbil product for any purposes specified in (1) through (6) below. Moreover, you are required to provide your Equipment with fool-proof design, fail-safe design, anti-flame propagation design, fault avoidance, fault tolerance, and other kinds of protection/safety circuit design on your own responsibility to ensure reliability and safety, whereby preventing problems caused by failure or nonconformity.

- (1) For use under such conditions or in such environments as not stated in technical documents, including catalogs, specification, and instruction manuals
- (2) For use of specific purposes, such as:
 - * Nuclear energy/radiation related facilities
[When used outside a radiation controlled area and where nuclear power quality is not required]
[When the limit switch for nuclear power is used]
 - * Machinery or equipment for space/sea bottom
 - * Transportation equipment
[Railway, aircraft, vessels, vehicle equipment, etc.]
 - * Antidisaster/crime-prevention equipment
 - * Burning appliances
 - * Electrothermal equipment
 - * Amusement facilities
 - * Facilities/applications associated directly with billing
- (3) Supply systems such as electricity/gas/water supply systems, large-scale communication systems, and traffic/air traffic control systems requiring high reliability
- (4) Facilities that are to comply with regulations of governmental/public agencies or specific industries
- (5) Machinery or equipment that may affect human lives, human bodies or properties
- (6) Other machinery or equipment equivalent to those set forth in items (1) to (5) above which require high reliability and safety

4. Precautions against long-term use

Use of Azbil Corporation's products, including switches, which contain electronic components, over a prolonged period may degrade insulation or increase contact-resistance and may result in heat generation or any other similar problem causing such product or switch to develop safety hazards such as smoking, ignition, and electrification. Although acceleration of the above situation varies depending on the conditions or environment of use of the products, you are required not to use any Azbil Corporation's products for a period exceeding ten (10) years unless otherwise stated in specifications or instruction manuals.

5. Recommendation for renewal

Mechanical components, such as relays and switches, used for Azbil Corporation's products will reach the end of their life due to wear by repetitious open/close operations.

In addition, electronic components such as electrolytic capacitors will reach the end of their life due to aged deterioration based on the conditions or environment in which such electronic components are used. Although acceleration of the above situation varies depending on the conditions or environment of use, the number of open/close operations of relays, etc. as prescribed in specifications or instruction manuals, or depending on the design margin of your machine or equipment, you are required to renew any Azbil Corporation's products every 5 to 10 years unless otherwise specified in specifications or instruction manuals. System products, field instruments (sensors such as pressure/flow/level sensors, regulating valves, etc.) will reach the end of their life due to aged deterioration of parts. For those parts that will reach the end of their life due to aged deterioration, recommended replacement cycles are prescribed. You are required to replace parts based on such recommended replacement cycles.

6. Other precautions

Prior to your use of Azbil Corporation's products, you are required to understand and comply with specifications (e.g., conditions and environment of use), precautions, warnings/cautions/notices as set forth in the technical documents prepared for individual Azbil Corporation's products, such as catalogs, specifications, and instruction manuals to ensure the quality, reliability, and safety of those products.

7. Changes to specifications

Please note that the descriptions contained in any documents provided by azbil are subject to change without notice for improvement or for any other reason. For inquires or information on specifications as you may need to check, please contact our branch offices or sales offices, or your local sales agents.

8. Discontinuance of the supply of products/parts

Please note that the production of any Azbil Corporation's product may be discontinued without notice. After manufacturing is discontinued, we may not be able to provide replacement products even within the warranty period.

For repairable products, we will, in principle, undertake repairs for five (5) years after the discontinuance of those products. In some cases, however, we cannot undertake such repairs for reasons, such as the absence of repair parts. For system products, field instruments, we may not be able to undertake parts replacement for similar reasons.

9. Scope of services

Prices of Azbil Corporation's products do not include any charges for services such as engineer dispatch service. Accordingly, a separate fee will be charged in any of the following cases:

- (1) Installation, adjustment, guidance, and attendance at a test run
- (2) Maintenance, inspection, adjustment, and repair
- (3) Technical guidance and technical education
- (4) Special test or special inspection of a product under the conditions specified by you

Please note that we cannot provide any services as set forth above in a nuclear energy controlled area (radiation controlled area) or at a place where the level of exposure to radiation is equivalent to that in a nuclear energy controlled area.

azbil

Specifications are subject to change without notice. (11)

Azbil Corporation
Advanced Automation Company

1-12-2 Kawana, Fujisawa
Kanagawa 251-8522 Japan

URL: <https://www.azbil.com>

1st edition: Feb. 2018 (V)
5th edition: Feb. 2024 (S)